



Discrete valve body piping  
Pilot operated 3, 5-port pneumatic valve

# 3KA1/4KA1/2/3/4 Series

● Cylinder bore size:  $\varnothing 20$  to  $\varnothing 160$



Refer to the Ending for details.



- 4GA/B
- M4GA/B
- MN4GA/B
- 4GA/B (master)
- 4GB With sensor
- 4GD/E
- M4GD/E
- MN4GD/E
- 4GA4/B4
- MN3E MN4E
- W4GA/B2
- W4GB4
- MN3S0 MN4S0
- 4SA/B0
- 4KA/B**
- 4KA/B (master)
- 4F
- 4F (master)
- PV5G GMF
- PV5 GMF
- PV5S-0
- 3Q
- MV3QR
- 3MA/B0
- 3PA/B
- P/M/B
- NP/NAP NVP
- 4G\*0EJ
- 4F\*0EX
- 4F\*0E
- HMV HSV
- 2QV 3QV
- SKH
- Silencer
- TotAirSys (Total Air)
- TotAirSys (Gamma)
- Ending

## JIS symbol

- 3-port valve  
2-position NC single
- 3-port valve  
2-position NO single
- 3-port valve  
2-position double
- 5-port valve  
2-position single
- 5-port valve  
2-position double
- 5-port valve  
3-position all ports closed
- 5-port valve  
3-position A/B/R connection
- 5-port valve  
3-position P/A/B connection
- 5-port valve  
3-position P/A/B connection

## Common specifications

Item	Description
Valve and operation	Pilot operated soft spool valve
Working fluid	Compressed air
Max. working pressure MPa	0.70 ( $\approx 100$ psi, 7 bar)
Min. working pressure MPa	Refer to Individual specifications listed below
Proof pressure MPa	1.05 ( $\approx 150$ psi, 10.5 bar)
Ambient temperature $^{\circ}\text{C}$	-5 ( $23^{\circ}\text{F}$ ) to 50 ( $122^{\circ}\text{F}$ ) (no freezing)
Fluid temperature $^{\circ}\text{C}$	5 ( $41^{\circ}\text{F}$ ) to 50 ( $122^{\circ}\text{F}$ )
Lubrication	Not required
Degree of protection	Dust-proof
Vibration resistance $\text{m/s}^2$	50 or less
Shock resistance $\text{m/s}^2$	300 or less
Atmosphere	Cannot be used in corrosive gas environment.

## Electrical specifications

Item		3KA1, 4KA1/2	4KA3/4
Rated voltage	AC	100,200 ( 50 / 60 Hz )	
	DC	24	
Voltage fluctuation range		$\pm 10\%$	
Starting current	AC 100 V	0.056/0.044	0.046/0.042
	A AC 200 V	0.028/0.022	0.023/0.021
Holding current	AC 100 V	0.028/0.022	0.023/0.021
	A AC 200 V	0.014/0.011	
	DC 24 V	0.075	
Power consumption	AC 100 V	1.8 / 1.4 (1.8 / 1.5)	1.6 / 1.3 (1.8 / 1.5)
	W AC 200 V	1.8 / 1.4 (1.8 / 1.5)	1.6 / 1.3 (1.8 / 1.5)
	( ) : With indicator	DC 24 V	1.8 (2.0)
Thermal class		B (molded coil)	
Temperature rise $^{\circ}\text{C}$		43	30

Reference: 100 VAC 50/60 Hz can be used with a rated voltage of 110 VAC 60 Hz and 200 VAC 50/60 Hz can be used with 220 VAC 60 Hz.

## Individual specifications

1 MPa  $\approx$  145.0 psi, 1 MPa = 10 bar

Item			3KA1	4KA1	4KA2	4KA3	4KA4
Min. working pressure	2-position	Single	0.15	0.15	0.15	0.15	0.15
		Double			0.10	0.10	0.10
MPa	3-position		-	0.20	0.20	0.20	0.20
Port size	P/A/B port		M5 Push-in fitting $\varnothing 4, \varnothing 6$	M5 Push-in fitting $\varnothing 4, \varnothing 6$	Rc1/8, G1/8, NPT1/8 Push-in fitting $\varnothing 6, \varnothing 8$	Rc1/4, G1/4, NPT1/4 Push-in fitting $\varnothing 8, \varnothing 10$	Rc3/8, G3/8, NPT3/8 Push-in fitting $\varnothing 10, \varnothing 12$
	R1/R2 port		M5	M5	Rc1/8, G1/8, NPT1/8	Rc1/4, G1/4, NPT1/4	Rc3/8, G3/8, NPT3/8

## Performance/characteristics by model

Item		3KA1	4KA1	4KA2	4KA3	4KA4
Response time	2-position	30 or less	30 or less	30 or less	30 or less	30 or less
*1	ms 3-position	-	60 or less	60 or less	60 or less	60 or less

\*1: The response time is the value at 0.5 MPa working pressure, with no lubrication, and with the power ON. It depends on the pressure and the lubricant quality.

## Weight

Item			3KA1	4KA1	4KA2	4KA3	4KA4
Weight	g	2-position Single	70	70	115	214	325
		Double	110	110	155	315	435
	3-position	-	120	170	354	505	

## Flow characteristics

Model No.	Solenoid position	C[dm <sup>3</sup> /(s·bar)]	b	
3KA1	2-position	0.65	0.37	
4KA1	2-position	0.65	0.37	
	3-position	All ports closed	0.60	0.32
		A/B/R connection	0.68	0.39
		P/A/B connection	0.61	0.36
4KA2	2-position	2.6	0.43	
	3-position	All ports closed	2.3	0.43
		A/B/R connection	2.9	0.34
		P/A/B connection	2.3	0.42
4KA3	2-position	5.6	0.49	
	3-position	All ports closed	4.1	0.60
		A/B/R connection	4.1	0.62
		P/A/B connection	4.2	0.68
4KA4	2-position	9.8	0.49	
	3-position	All ports closed	8.2	0.54
		A/B/R connection	11	0.50
		P/A/B connection	8.4	0.54

\*1: Effective cross-sectional area S and sonic conductance C are converted as  $S \approx 5.0 \times C$ .

\*2: Flow characteristics are values when the port size is M5 (3KA1, 4KA1), Rc1/8 (4KA2), Rc1/4 (4KA3), or Rc3/8 (4KA4).

### Ozone-proof specifications (Ending Page 5)

\*\* - Voltage - **P11**

### Copper and PTFE free specifications

● Copper- and PTFE-based materials are not used in the flow path.

\*\* - Voltage - **P6**

### CE marking specifications

\*\* - Voltage - **ST**

• Standard voltage of 24 VDC or less is CE marking-compatible even if the model No. is not indicated with "ST".

4GA/B
M4GA/B
MN4GA/B
4GA/B (master)
4GB With sensor
4GD/E
M4GD/E
MN4GD/E
4GA4/B4
MN3E
MN4E
W4GA/B2
W4GB4
MN3S0
MN4S0
4SA/B0
<b>4KA/B</b>
4KA/B (master)
4F
4F (master)
PV5G
GMF
PV5
GMF
PV5S-0
3Q
MV3QR
3MA/B0
3PA/B
P/M/B
NP/NAP
NVP
4G*0EJ
4F*0EX
4F*0E
HMV
HSV
2QV
3QV
SKH
Silencer
TotAirSys (Total Air)
TotAirSys (Gamma)
Ending

# 3KA1/4KA1 to 4 Series

Discrete valve; body piping

## How to order

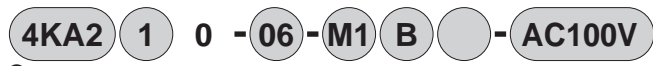

● Single solenoid valve for manifold



**A** Model No. **B** Solenoid position

**C** Port size

**D** Manual override

**E** Electrical connections  
\* Refer to page 1263 for the circuit diagram with surge suppressor/lamp.

**F** Other options

**G** Voltage

[Table 1] Compact terminal box L/LS compatibility table

Code	Description		3KA1	4KA1	4KA2	4KA3	4KA4	Surge suppressor
L	Without lead wire	With indicator lamp	AC	●	●	●	●	●
		DC				●	●	
	with surge suppressor/indicator lamp	AC						
		DC	●	●	●			Integrated
LS	Without lead wire	with surge suppressor/indicator lamp	AC	●	●	●	●	Integrated
		DC				●	●	Integrated

### ⚠ Precautions for model No. selection

\*1 : The compact terminal boxes of 3KA1, 4KA1, and 4KA2 and the DC voltage models of L, and LS are equipped with a surge suppressor.

\*2 : The surge suppressor for attachment is a suppression connector when the grommet lead wire is 24 VDC or less. (Refer to page 1262)

\*3 : The surge suppressor can only be selected when the grommet lead wire or compact terminal box "B" has been selected for the electrical connections.

\*4 : With regard to the printed model No., although the model No. when placing an order is "4KA□□9", the model No. listed on the product name plate will be "4KA□□0".

[Example of model No.]

## 4KA210-06-M1BP-AC100V

- A** Model : 4KA2
- B** Solenoid position : 2-position single
- C** Port size : Rc1/8
- D** Manual override : Locking manual override
- E** Electrical connections: Compact terminal box/without lead wire
- F** Other options : With mounting plate
- G** Voltage : 100 VAC 50/60 Hz

\* Gasket/mounting screw attached (\*4)

		A Model No.									
		3KA1	4KA1	4KA2	4KA3	4KA4					
Solenoid position <b>B</b>	Code	Description									
	1	●	●	●	●	●					
	2	●	●	●	●	●					
	3		●	●	●	●					
	4		●	●	●	●					
	5		●	●	●	●					
Port size <b>C</b>	1	●									
	11	●									
	Port	P/A/B port	R1/R2 port								
			(1) = M5 (2) = Rc1/8 (3) = Rc1/4 (4) = Rc3/8								
	M5	M5	(1)	(1)							
	06	Rc1/8			(2)						
	08	Rc1/4				(3)					
	10	Rc3/8				(4)					
	GS4	ø4 Push-in fitting	(1)	(1)							
	GS6	ø6 Push-in fitting	(1)	(1)	(2)						
	GS8	ø8 Push-in fitting			(2)	(3)					
	GS10	ø10 Push-in fitting				(3) (4)					
GS12	ø12 Push-in fitting				(4)						
Port	P/A/B port	R1/R2 port									
		(1) = M5 (5) = NPT1/8 (6) = NPT1/4 (7) = NPT3/8									
	06N	NPT1/8			(5)						
	08N	NPT1/4				(6)					
	10N	NPT3/8				(7)					
	GS4N	ø4 Push-in fitting	(1)	(1)							
	GS6N	ø6 Push-in fitting	(1)	(1)	(5)						
	GS8N	ø8 Push-in fitting			(5)	(6)					
	GS10N	ø10 Push-in fitting				(6) (7)					
	GS12N	ø12 Push-in fitting				(7)					
	Port	P/A/B port	R1/R2 port								
			(1) = M5 (8) = G1/8 (9) = G1/4 (10) = G3/8								
06G	G1/8			(8)							
08G	G1/4				(9)						
10G	G3/8				(10)						
GS4G	ø4 Push-in fitting	(1)	(1)								
GS6G	ø6 Push-in fitting	(1)	(1)	(8)							
GS8G	ø8 Push-in fitting			(8)	(9)						
GS10G	ø10 Push-in fitting				(9) (10)						
GS12G	ø12 Push-in fitting				(10)						
<b>D</b>	Blank	Non-locking manual override									
	M1	Locking manual override									
<b>E</b>	Refer to the electrical connections list on the next page.										
<b>F</b>	Blank	No option									
	P	Mounting plate (compatible only with 2-position single)									
	S	Surge suppressor attached (*2) (*3)									
	-A	Coolant supported (packing: FKM)									
<b>G</b>	Voltage	Option	Standard	AC100V	100 VAC 50/60 Hz		●	●	●	●	●
				AC200V	200 VAC 50/60 Hz		●	●	●	●	●
				DC24V	24 VDC		●	●	●	●	●
				DC12V	12 VDC		●	●	●	●	●
				AC110V	110 VAC 50/60 Hz		●	●	●	●	●
				AC220V	220 VAC 50/60 Hz		●	●	●	●	●
<b>* Other custom order products</b>											
AC24V		●	●	●	●	●					
AC115V		●	●	●	●	●					
AC120V		●	●	●	●	●					

# 3KA1/4KA1 to 4 Series

Discrete valve; body piping

[Electrical connections list]

		A Model No.				
		3KA1	4KA1	4KA2	4KA3	4KA4
Code	Description					
E	Grommet lead wire					
	Blank	Grommet lead wire (300 mm)	●	●	●	●
	<b>Compact terminal box</b>					
	B	Without lead wire	●	●	●	●
	L	Without lead wire	Refer to [Table 1] on the previous page for details (*1)			
	LS	Without lead wire, with surge suppressor/lamp	Refer to [Table 1] on the previous page for details (*1)			
	C-connector (lead wire lateral direction)					
	C	Lead wire length (300 mm)	●	●	●	●
	C00	Lead wire length (500 mm)	●	●	●	●
	C01	Lead wire length (1000 mm)	●	●	●	●
	C02	Lead wire length (2000 mm)	●	●	●	●
	C03	Lead wire length (3000 mm)	●	●	●	●
	C1	Without lead wire	●	●	●	●
	C2	Lead wire length (300 mm) with surge suppressor/lamp	●	●	●	●
	C20	Lead wire length (500 mm) with surge suppressor/lamp	●	●	●	●
	C21	Lead wire length (1000 mm) with surge suppressor/lamp	●	●	●	●
	C22	Lead wire length (2000 mm) with surge suppressor/lamp	●	●	●	●
	C23	Lead wire length (3000 mm) with surge suppressor/lamp	●	●	●	●
	C3	Without lead wire, with surge suppressor/lamp	●	●	●	●
	D-connector (lead wire upward direction)					
	D	Lead wire length (300 mm)	●	●	●	●
	D00	Lead wire length (500 mm)	●	●	●	●
	D01	Lead wire length (1000 mm)	●	●	●	●
	D02	Lead wire length (2000 mm)	●	●	●	●
	D03	Lead wire length (3000 mm)	●	●	●	●
	D1	Without lead wire	●	●	●	●
	D2	Lead wire length (300 mm) with surge suppressor/lamp	●	●	●	●
	D20	Lead wire length (500 mm) with surge suppressor/lamp	●	●	●	●
	D21	Lead wire length (1000 mm) with surge suppressor/lamp	●	●	●	●
	D22	Lead wire length (2000 mm) with surge suppressor/lamp	●	●	●	●
	D23	Lead wire length (3000 mm) with surge suppressor/lamp	●	●	●	●
	D3	Without lead wire, with surge suppressor/lamp	●	●	●	●

- 4GA/B
- M4GA/B
- MN4GA/B
- 4GA/B (master)
- 4GB With sensor
- 4GD/E
- M4GD/E
- MN4GD/E
- 4GA4/B4
- MN3E MN4E
- W4GA/B2
- W4GB4
- MN3S0 MN4S0
- 4SA/B0
- 4KA/B**
- 4KA/B (master)
- 4F
- 4F (master)
- PV5G GMF
- PV5 GMF
- PV5S-0
- 3Q
- MV3QR
- 3MA/B0
- 3PA/B
- P/M/B
- NP/NAP NVP
- 4G\*0EJ
- 4F\*0EX
- 4F\*0E
- HMV HSV
- 2QV 3QV
- SKH
- Silencer
- TotAirSys (Total Air)
- TotAirSys (Gamma)
- Ending

# 3KA1/4KA1 Series

Discrete valve; body piping

## Internal structure and parts list

- 4GA/B
- M4GA/B
- MN4GA/B
- 4GA/B (master)
- 4GB With sensor
- 4GD/E
- M4GD/E
- MN4GD/E
- 4GA4/B4
- MN3E
- MN4E
- W4GA/B2
- W4GB4
- MN3S0
- MN4S0
- 4SA/B0
- 4KA/B**
- 4KA/B (master)
- 4F
- 4F (master)
- PV5G
- GMF
- PV5
- GMF
- PV5S-0
- 3Q
- MV3QR
- 3MA/B0
- 3PA/B
- P/M/B
- NP/NAP
- NVP
- 4G\*0EJ
- 4F\*0EX
- 4F\*0E
- HMV
- HSV
- 2QV
- 3QV
- SKH
- Silencer
- TotAirSys (Total Air)
- TotAirSys (Gamma)
- Ending

### 4KA110

● 2-position single

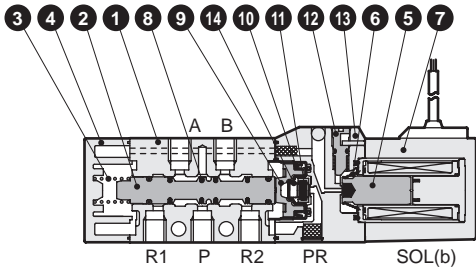
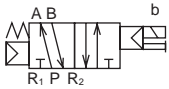

### 3KA110-NC

● 2-position single / NC

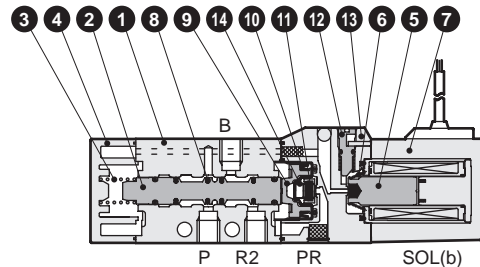
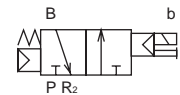

### 4KA120

● 2-position double

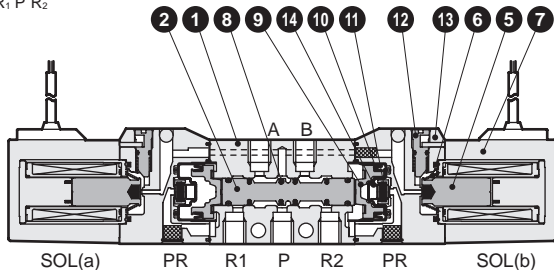
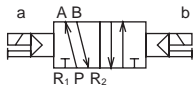

### 3KA1110-NO

● 2-position single / NO

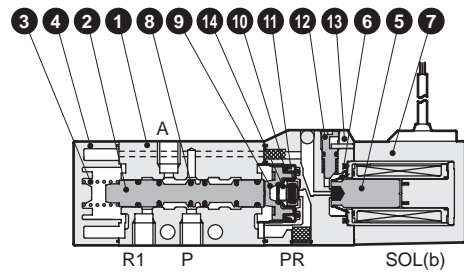

### 4KA130

● 3-position all ports closed



### 4KA140

● 3-position A/B/R connection

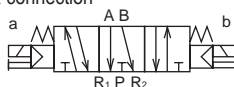

### 4KA150

● 3-position P/A/B connection

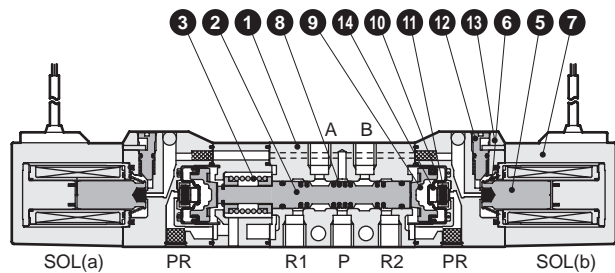
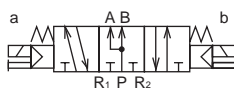

## Main parts list

No.	Part name	Material
1	Body	Aluminum alloy die-casting
2	Valving element (spool)	Aluminum
3	Valve spring	Stainless steel
4	Cap	Resin
5	Plunger	-
6	Plunger spring	-
7	Coil assembly	-
8	Spool packing	Nitrile rubber
9	Piston	Resin
10	Piston packing	Nitrile rubber
11	Valve seat	Nitrile rubber
12	Manual button	Resin
13	Pilot valve	Resin
14	Valve seat spring	Stainless steel

## Repair parts list

No./part name	2 8	9 10	5 6 7
Model No.	Spool assembly	Piston assembly	Coil assembly *
3KA110	4K9-110	4K9-151	4K1L- <b>E</b> electrical connection option code Blank for grommet lead wire
3KA1110			
3KA120	4K9-118	4K9-151	COIL - <b>G</b> Voltage
4KA110			
4KA120	4K9-118	4K9-152	
4KA130			
4KA140	4K9-112		
4KA150			

\* The compact terminal box and connector of the coil assembly will come assembled and included with the options of the descriptions indicated with model No. selection.

## Internal structure and parts list

### 4KA210

- 2-position single

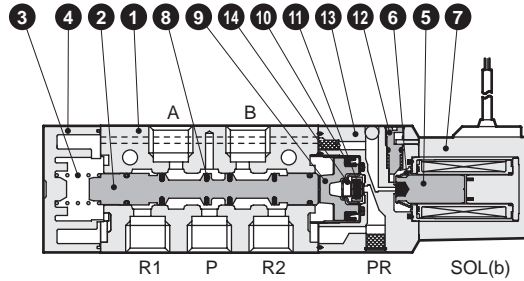
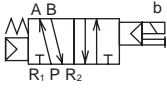

### 4KA220

- 2-position double

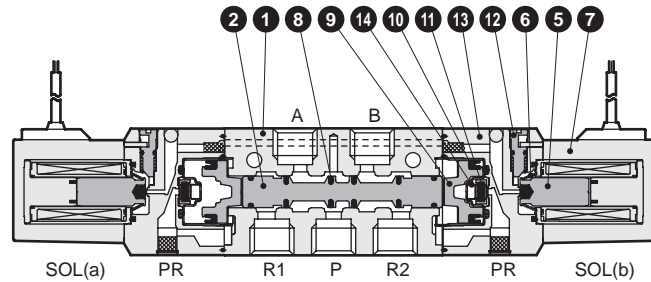
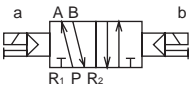

### 4KA230

- 3-position all ports closed

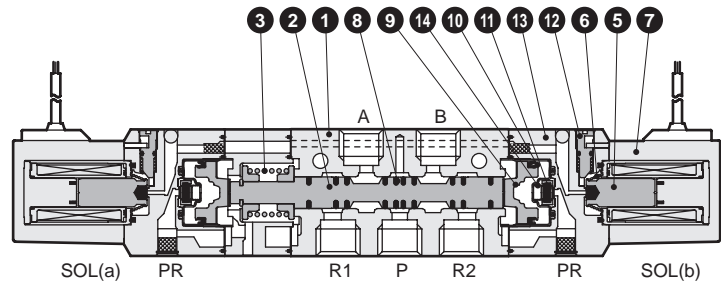
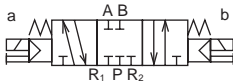

### 4KA240

- 3-position A/B/R connection



### 4KA250

- 3-position P/A/B connection



## Main parts list

No.	Part name	Material
1	Body	Aluminum alloy die-casting
2	Valving element (spool)	Aluminum
3	Valve spring	Stainless steel
4	Cap	Resin
5	Plunger	-
6	Plunger spring	-
7	Coil assembly	-
8	Spool packing	Nitrile rubber
9	Piston	Resin
10	Piston packing	Nitrile rubber
11	Valve seat	Nitrile rubber
12	Manual button	Resin
13	Pilot valve	Resin
14	Valve seat spring	Stainless steel

## Repair parts list

No./part name	2 8	9 10	5 6 7
Model No.	Spool assembly	Piston assembly	Coil assembly *
4KA210	4K9-150	4K9-153	4K1L <b>E</b> electrical connection option code Blank for grommet lead wire COIL - <b>G</b> Voltage
4KA220	4K9-126		
4KA230	4K9-127		
4KA250	4K9-129		

\* The compact terminal box and connector of the coil assembly will come assembled and included with the options of the descriptions indicated with model No. selection.

4GA/B
M4GA/B
MN4GA/B
4GA/B (master)
4GB With sensor
4GD/E
M4GD/E
MN4GD/E
4GA4/B4
MN3E MN4E
W4GA/B2
W4GB4
MN3S0 MN4S0
4SA/B0
<b>4KA/B</b>
4KA/B (master)
4F
4F (master)
PV5G GMF
PV5 GMF
PV5S-0
3Q
MV3QR
3MA/B0
3PA/B
P/M/B
NP/NAP NVP
4G*0EJ
4F*0EX
4F*0E
HMV HSV
2QV 3QV
SKH
Silencer
TotAirSys (Total Air)
TotAirSys (Gamma)
Ending



# 4KA3 Series

Discrete valve; body piping

## Internal structure and parts list

- 4GA/B
- M4GA/B
- MN4GA/B
- 4GA/B (master)
- 4GB With sensor
- 4GD/E
- M4GD/E
- MN4GD/E
- 4GA4/B4
- MN3E
- MN4E
- W4GA/B2
- W4GB4
- MN3S0
- MN4S0
- 4SA/B0
- 4KA/B**
- 4KA/B (master)
- 4F
- 4F (master)
- PV5G
- GMF
- PV5
- GMF
- PV5S-0
- 3Q
- MV3QR
- 3MA/B0
- 3PA/B
- P/M/B
- NP/NAP
- NVP
- 4G\*0EJ
- 4F\*0EX
- 4F\*0E
- HMV
- HSV
- 2QV
- 3QV
- SKH
- Silencer
- TotAirSys (Total Air)
- TotAirSys (Gamma)
- Ending

### 4KA310

● 2-position single

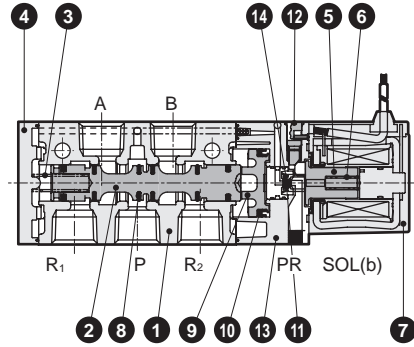
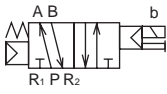

### 4KA320

● 2-position double

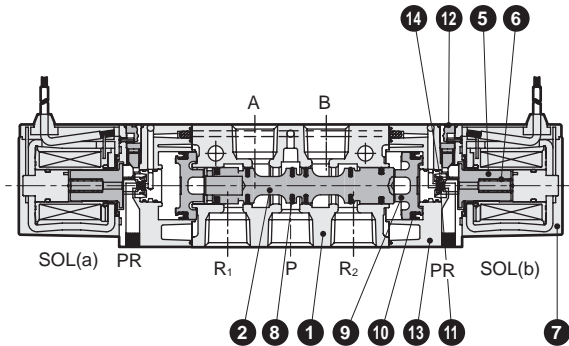
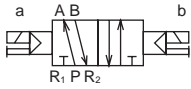

### 4KA330

● 3-position all ports closed

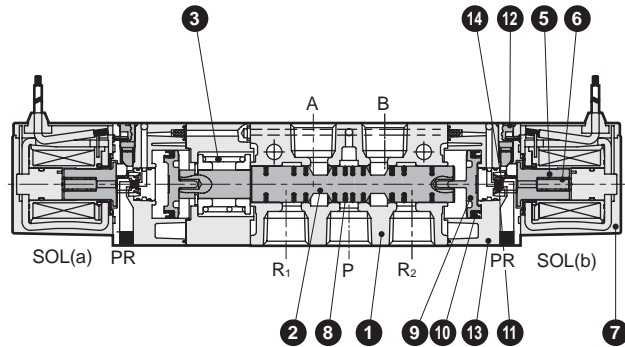
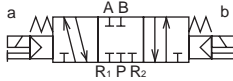

### 4KA340

● 3-position A/B/R connection



### 4KA350

● 3-position P/A/B connection

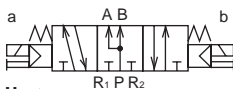

## Main parts list

## Repair parts list

No.	Part name	Material	No./part name		2 8		9 10		5 6 7		
			Model No.	Spool assembly	Piston assembly	Coil assembly *					
1	Body	Aluminum alloy die-casting	4KA310								
2	Valving element (spool)	Aluminum	4KA320	4K9-133							
3	Valve spring	Stainless steel	4KA330	4K9-134							
4	Cap	Resin	4KA340	4K9-135							
5	Plunger	-	4KA350	4K9-136							
6	Plunger spring	-									
7	Coil assembly	-									
8	Spool packing	Nitrile rubber									
9	Piston	Resin									
10	Piston packing	Nitrile rubber									
11	Valve seat	Nitrile rubber									
12	Manual button	Resin									
13	Pilot valve	Resin									
14	Valve seat spring	Stainless steel									

\* The terminal box and connector of the coil assembly will come assembled and included with the options of the descriptions indicated with model No. selection.

## Internal structure and parts list

### 4KA410

● 2-position single

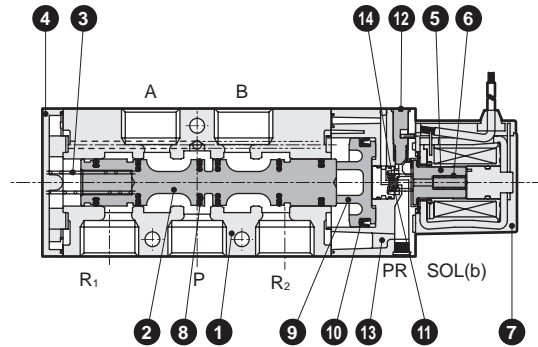
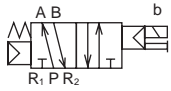

### 4KA420

● 2-position double

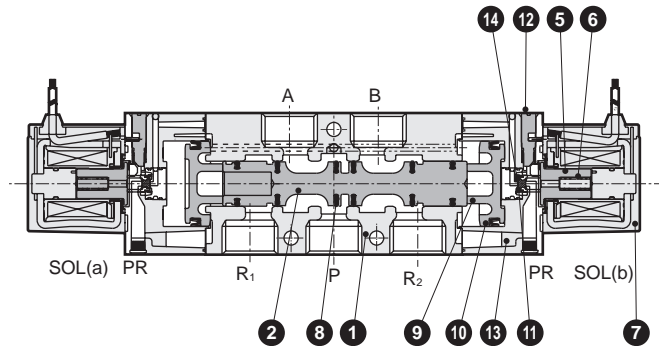
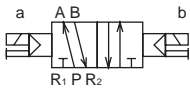

### 4KA430

● 3-position all ports closed

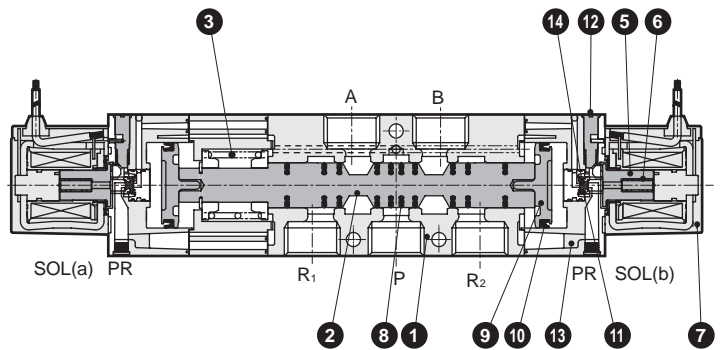
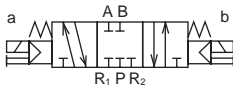

### 4KA440

● 3-position A/B/R connection



### 4KA450

● 3-position P/A/B connection



## Main parts list

No.	Part name	Material
1	Body	Aluminum alloy die-casting
2	Valving element (spool)	Aluminum
3	Valve spring	Stainless steel
4	Cap	Resin
5	Plunger	-
6	Plunger spring	-
7	Coil assembly	-
8	Spool packing	Nitrile rubber
9	Piston	Resin
10	Piston packing	Nitrile rubber
11	Valve seat	Nitrile rubber
12	Manual button	Resin
13	Pilot valve	Resin
14	Valve seat spring	Stainless steel

## Repair parts list

No./part name	2 8	9 10	5 6 7
Model No.	Spool assembly	Piston assembly	Coil assembly *
4KA410	4K9-140	4K9-144	4K3- <span style="border: 1px solid black; padding: 2px;">E</span> electrical connection option code Blank for grommet lead wire COIL - <span style="border: 1px solid black; padding: 2px;">G</span> Voltage
4KA420	4K9-141	4K9-145	
4KA430	4K9-142		
4KA440	4K9-143		

\* The terminal box and connector of the coil assembly will come assembled and included with the options of the descriptions indicated with model No. selection.

4GA/B
M4GA/B
MN4GA/B
4GA/B (master)
4GB With sensor
4GD/E
M4GD/E
MN4GD/E
4GA4/B4
MN3E
MN4E
W4GA/B2
W4GB4
MN3S0
MN4S0
4SA/B0
<b>4KA/B</b>
<b>4KA/B (master)</b>
4F
4F (master)
PV5G
GMF
PV5
GMF
PV5S-0
3Q
MV3QR
3MA/B0
3PA/B
P/M/B
NP/NAP
NVP
4G*0EJ
4F*0EX
4F*0E
HMV
HSV
2QV
3QV
SKH
Silencer
TotAirSys (Total Air)
TotAirSys (Gamma)
Ending



# 3KA1 Series

Discrete valve; body piping

## Dimensions

- 4GA/B
- M4GA/B
- MN4GA/B
- 4GA/B (master)
- 4GB With sensor
- 4GD/E
- M4GD/E
- MN4GD/E
- 4GA4/B4
- MN3E
- MN4E
- W4GA/B2
- W4GB4
- MN3S0
- MN4S0
- 4SA/B0
- 4KA/B**
- 4KA/B (master)
- 4F
- 4F (master)
- PV5G
- GMF
- PV5
- GMF
- PV5S-0
- 3Q
- MV3QR
- 3MA/B0
- 3PA/B
- P/M/B
- NP/NAP
- NVP
- 4G\*0EJ
- 4F\*0EX
- 4F\*0E
- HMV
- HSV
- 2QV
- 3QV
- SKH
- Silencer
- TotAirSys (Total Air)
- TotAirSys (Gamma)
- Ending

### 3KA110



● 2 position NC single: grommet lead wire

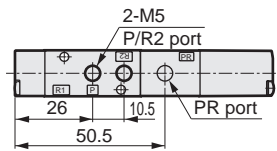
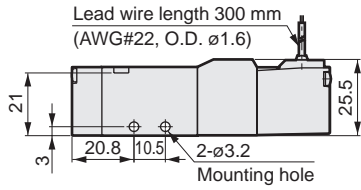
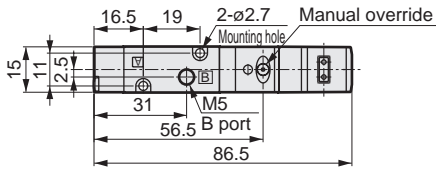

### 3KA1110



● 2 position NO single: grommet lead wire

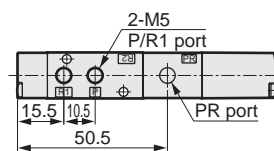
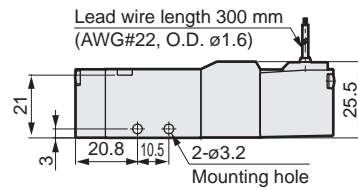
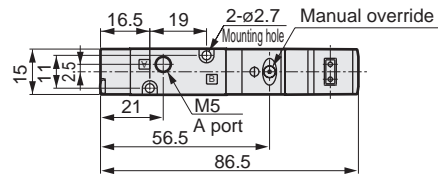

● Mounting plate: (P [2-position single only])

Material: Steel

Zinc chromate treatment

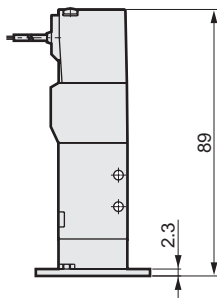
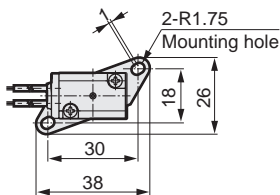

### 3KA120



● 2 position NC double: grommet lead wire

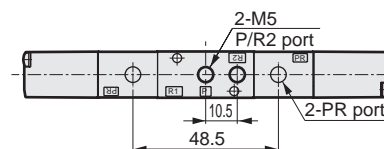
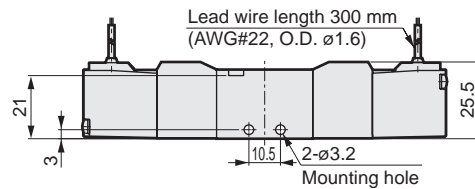
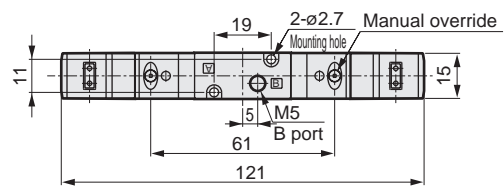

## Dimensions

- $\varnothing 4/\varnothing 6$  push-in fitting: (GS4\*/GS6\*)

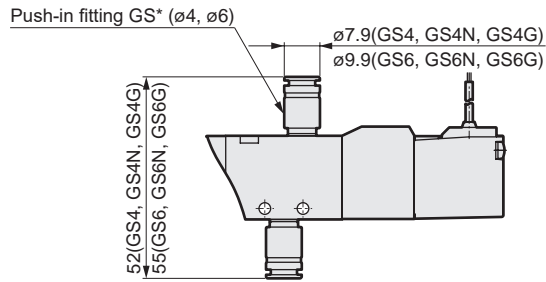

- Compact terminal box: (B [Without lamp]/L/LS [With lamp])

Without indicator lamp

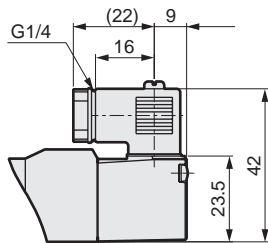

With indicator lamp

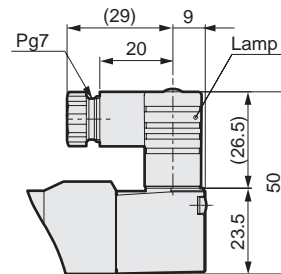

- C-connector: (C/C1/C0\*/C2/C2\*/C3)

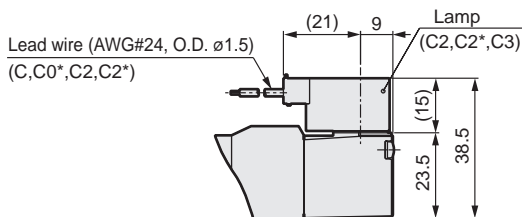

- D-connector: (D/D1/D0\*/D2/D2\*/D3)

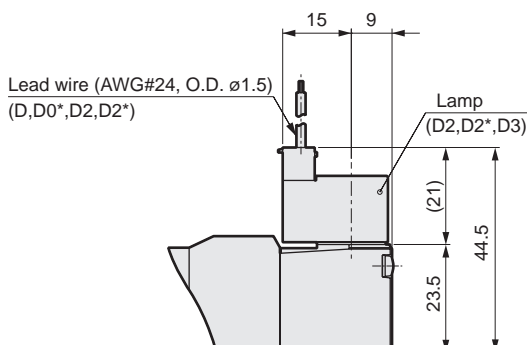

4GA/B
M4GA/B
MN4GA/B
4GA/B (master)
4GB With sensor
4GD/E
M4GD/E
MN4GD/E
4GA4/B4
MN3E
MN4E
W4GA/B2
W4GB4
MN3S0
MN4S0
4SA/B0
<b>4KA/B</b>
<b>4KA/B (master)</b>
4F
4F (master)
PV5G
GMF
PV5
GMF
PV5S-0
3Q
MV3QR
3MA/B0
3PA/B
P/M/B
NP/NAP
NVP
4G*0EJ
4F*0EX
4F*0E
HMV
HSV
2QV
3QV
SKH
Silencer
TotAirSys (Total Air)
TotAirSys (Gamma)
Ending

# 4KA1 Series

Discrete valve; body piping

## Dimensions

4GA/B
M4GA/B
MN4GA/B
4GA/B (master)
4GB With sensor
4GD/E
M4GD/E
MN4GD/E
4GA4/B4
MN3E
MN4E
W4GA/B2
W4GB4
MN3S0
MN4S0
4SA/B0
<b>4KA/B</b>
4KA/B (master)
4F
4F (master)
PV5G
GMF
PV5
GMF
PV5S-0
3Q
MV3QR
3MA/B0
3PA/B
P/M/B
NP/NAP
NVP
4G*0EJ
4F*0EX
4F*0E
HMV
HSV
2QV
3QV
SKH
Silencer
TotAirSys (Total Air)
TotAirSys (Gamma)
Ending

### 4KA110



● 2-position single: grommet lead wire

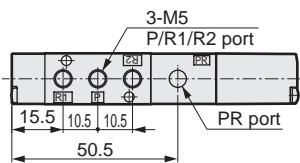
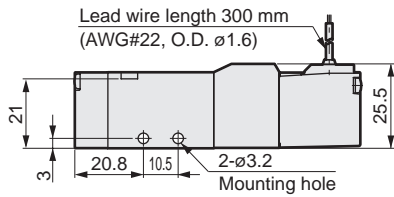
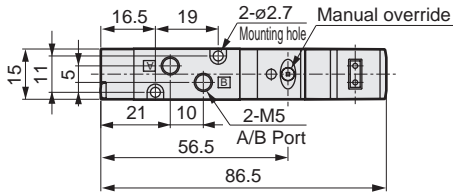

● Mounting plate: (P [2-position single only])

Material: Steel

Zinc chromate treatment

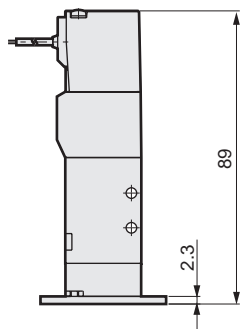
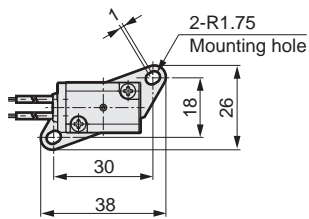

### 4KA120



● 2-position double: grommet lead wire

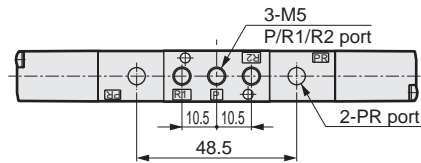
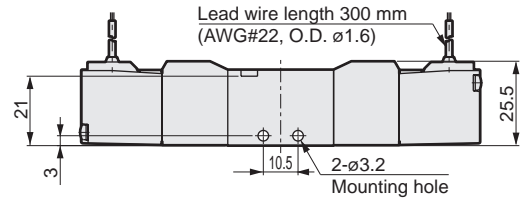
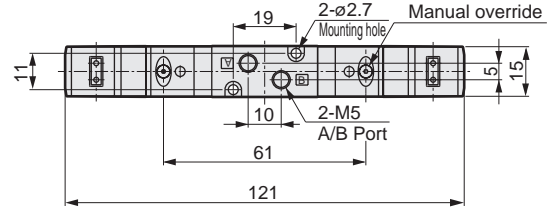

### 4KA140



● 3-position: grommet lead wire

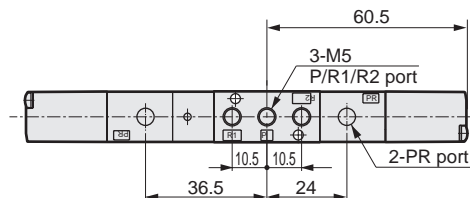
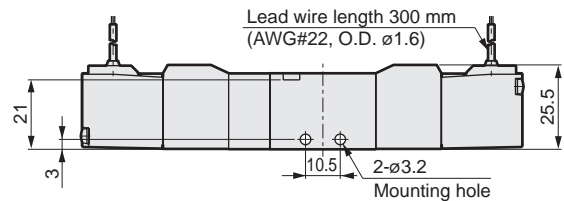
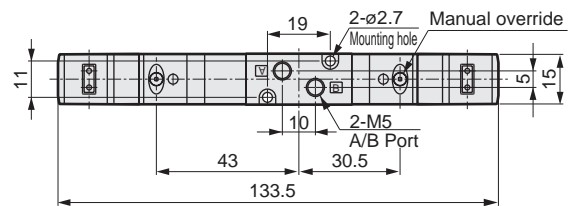

## Dimensions

- $\varnothing 4/\varnothing 6$  push-in fitting: (GS4\*/GS6\*)

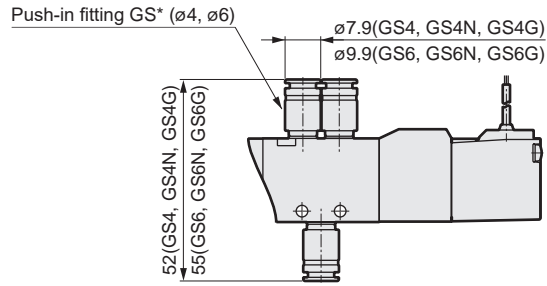

- Compact terminal box: (B [Without lamp]/L/LS [With lamp])

Without indicator lamp

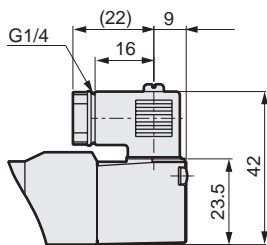

With indicator lamp

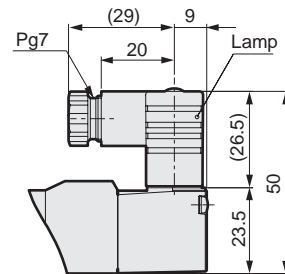

- C-connector: (C/C1/C0\*/C2/C2\*/C3)

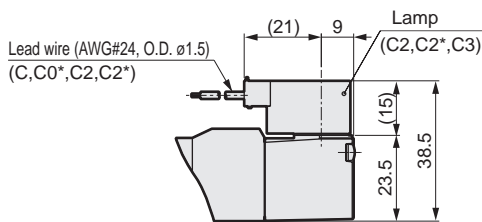

- D-connector: (D/D1/D0\*/D2/D2\*/D3)

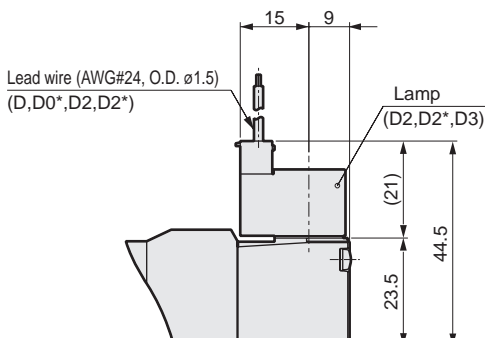

4GA/B
M4GA/B
MN4GA/B
4GA/B (master)
4GB With sensor
4GD/E
M4GD/E
MN4GD/E
4GA4/B4
MN3E
MN4E
W4GA/B2
W4GB4
MN3S0
MN4S0
4SA/B0
<b>4KA/B</b>
<b>4KA/B (master)</b>
4F
4F (master)
PV5G
GMF
PV5
GMF
PV5S-0
3Q
MV3QR
3MA/B0
3PA/B
P/M/B
NP/NAP
NVP
4G*0EJ
4F*0EX
4F*0E
HMV
HSV
2QV
3QV
SKH
Silencer
TotAirSys (Total Air)
TotAirSys (Gamma)
Ending

# 4KA2 Series

Discrete valve; body piping

## Dimensions

### 4KA210

● 2-position single: grommet lead wire

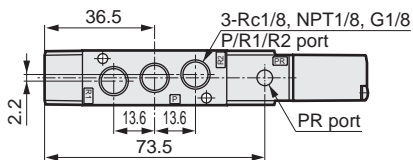
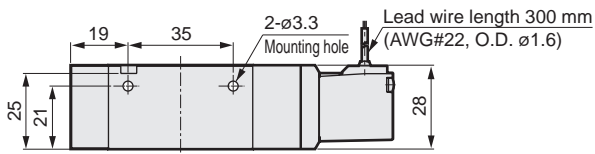
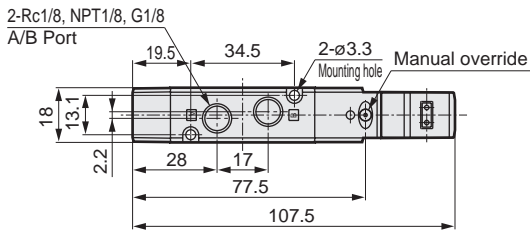

### 4KA220

● 2-position double: grommet lead wire

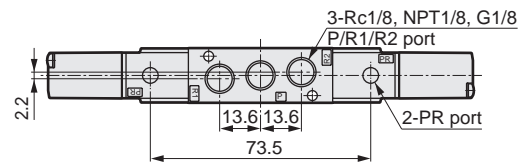
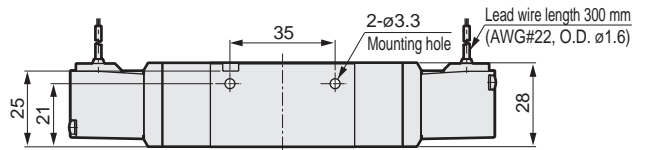
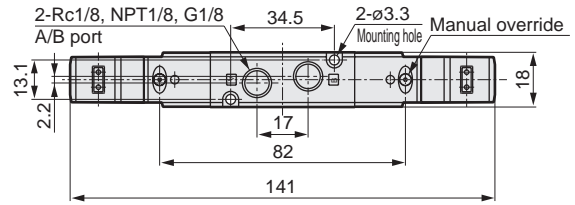

### 4KA240

● 3-position: grommet lead wire

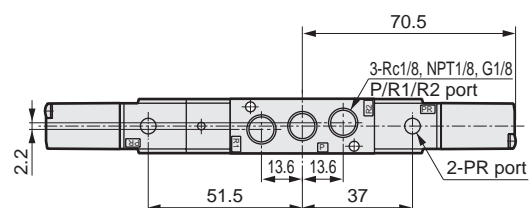
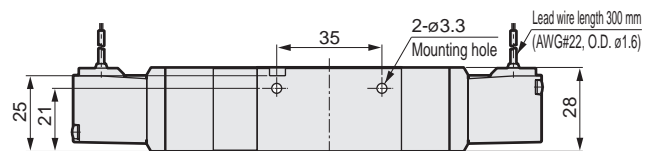
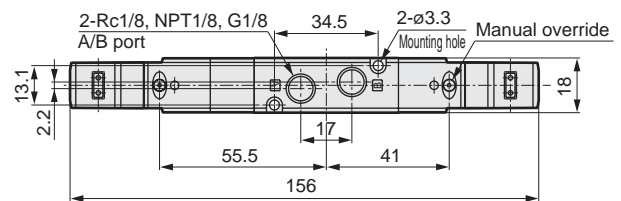

● Mounting plate: (P [2-position single only])

Material: Steel

Zinc chromate treatment

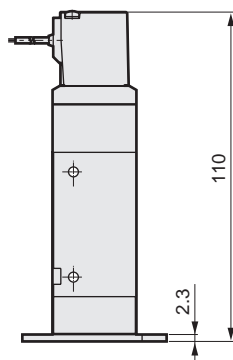
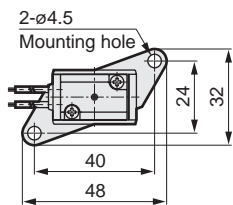

- 4GA/B
- M4GA/B
- MN4GA/B
- 4GA/B (master)
- 4GB With sensor
- 4GD/E
- M4GD/E
- MN4GD/E
- 4GA4/B4
- MN3E
- MN4E
- W4GA/B2
- W4GB4
- MN3S0
- MN4S0
- 4SA/B0
- 4KA/B**
- 4KA/B (master)
- 4F
- 4F (master)
- PV5G
- GMF
- PV5
- GMF
- PV5S-0
- 3Q
- MV3QR
- 3MA/B0
- 3PA/B
- P/M/B
- NP/NAP
- NVP
- 4G\*0EJ
- 4F\*0EX
- 4F\*0E
- HMV
- HSV
- 2QV
- 3QV
- SKH
- Silencer
- TotAirSys (Total Air)
- TotAirSys (Gamma)
- Ending

## Dimensions

- $\varnothing 6/\varnothing 8$  push-in fitting: (GS6\*/GS8\*)

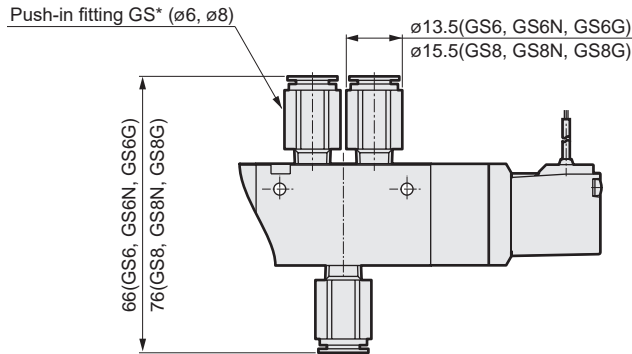

- Compact terminal box: (B [Without lamp]/L/LS [With lamp])

Without indicator lamp

With indicator lamp

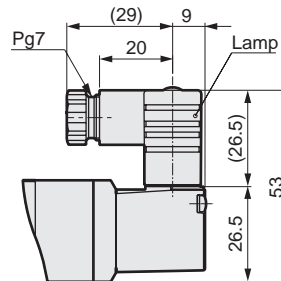
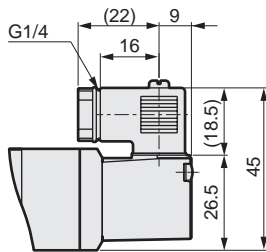

- C-connector: (C/C1/C0\*/C2/C2\*/C3)

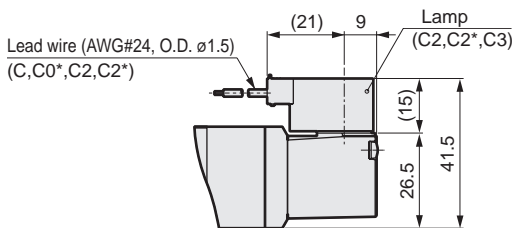

- D-connector: (D/D1/D0\*/D2/D2\*/D3)

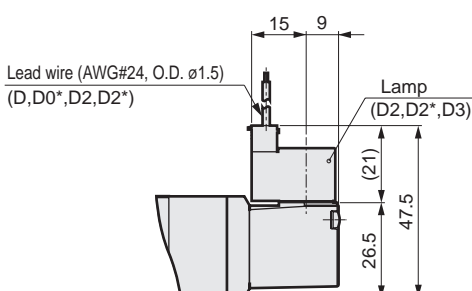

4GA/B
M4GA/B
MN4GA/B
4GA/B (master)
4GB With sensor
4GD/E
M4GD/E
MN4GD/E
4GA4/B4
MN3E
MN4E
W4GA/B2
W4GB4
MN3S0
MN4S0
4SA/B0
<b>4KA/B</b>
<b>4KA/B (master)</b>
4F
4F (master)
PV5G
GMF
PV5
GMF
PV5S-0
3Q
MV3QR
3MA/B0
3PA/B
P/M/B
NP/NAP
NVP
4G*0EJ
4F*0EX
4F*0E
HMV
HSV
2QV
3QV
SKH
Silencer
TotAirSys (Total Air)
TotAirSys (Gamma)
Ending



# 4KA3 Series

Discrete valve; body piping

## Dimensions

### 4KA310

● 2-position single: grommet lead wire

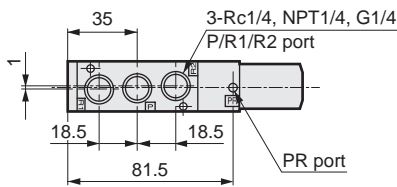
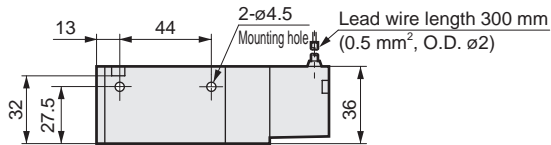
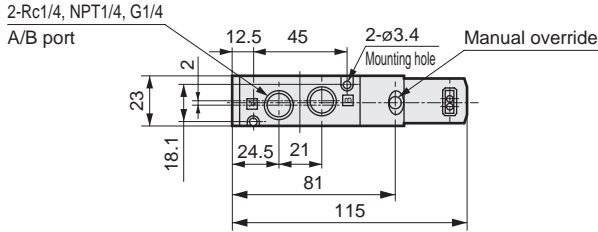

### 4KA320

● 2-position double: grommet lead wire

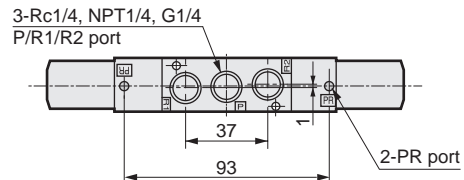
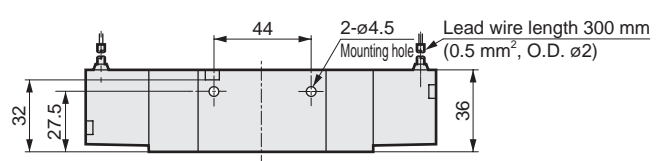
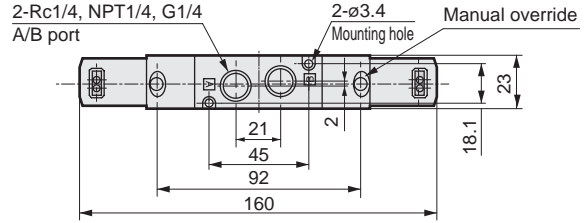

### 4KA340

● 3-position: grommet lead wire

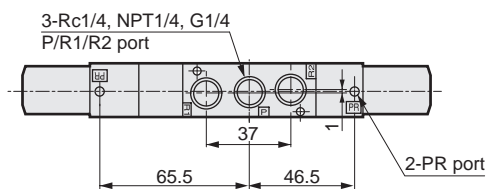
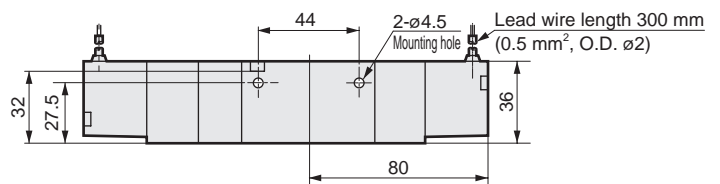
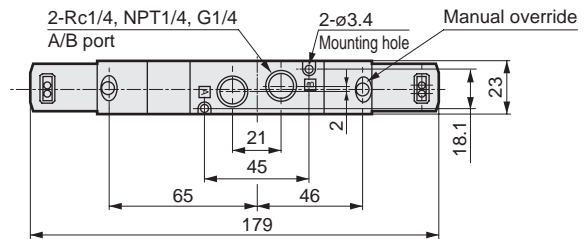

● Mounting plate: (P [2-position single only])

Material: Steel

Zinc chromate treatment

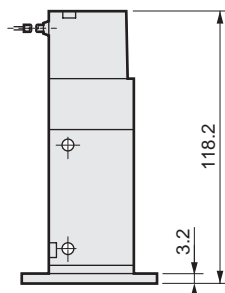
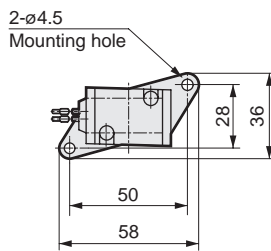

- 4GA/B
- M4GA/B
- MN4GA/B
- 4GA/B (master)
- 4GB With sensor
- 4GD/E
- M4GD/E
- MN4GD/E
- 4GA4/B4
- MN3E
- MN4E
- W4GA/B2
- W4GB4
- MN3S0
- MN4S0
- 4SA/B0
- 4KA/B**
- 4KA/B (master)
- 4F
- 4F (master)
- PV5G
- GMF
- PV5
- GMF
- PV5S-0
- 3Q
- MV3QR
- 3MA/B0
- 3PA/B
- P/M/B
- NP/NAP
- NVP
- 4G\*0EJ
- 4F\*0EX
- 4F\*0E
- HMV
- HSV
- 2QV
- 3QV
- SKH
- Silencer
- TotAirSys (Total Air)
- TotAirSys (Gamma)
- Ending

### Dimensions

●  $\varnothing 8/\varnothing 10$  push-in fitting: (GS8\*/GS10\*)

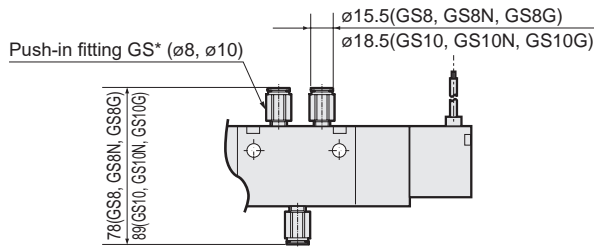

● Terminal box: (B/L/LS)

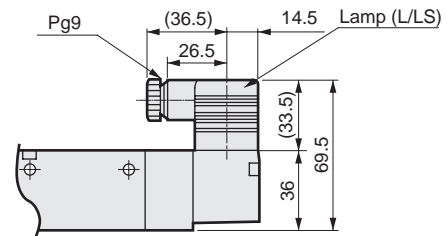

● C-connector: (C/C1/C0\*/C2/C2\*/C3)

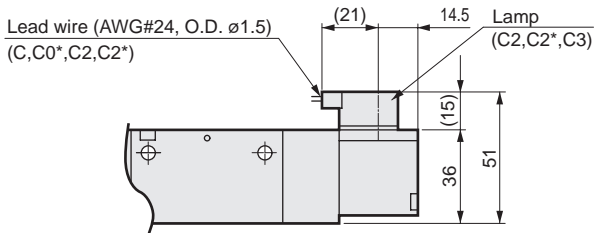

● D-connector: (D/D1/D0\*/D2/D2\*/D3)

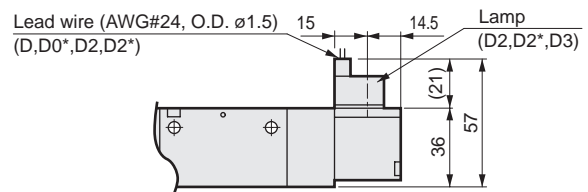

4GA/B
M4GA/B
MN4GA/B
4GA/B (master)
4GB With sensor
4GD/E
M4GD/E
MN4GD/E
4GA4/B4
MN3E
MN4E
W4GA/B2
W4GB4
MN3S0
MN4S0
4SA/B0
<b>4KA/B</b>
<b>4KA/B (master)</b>
4F
4F (master)
PV5G
GMF
PV5
GMF
PV5S-0
3Q
MV3QR
3MA/B0
3PA/B
P/M/B
NP/NAP
NVP
4G*0EJ
4F*0EX
4F*0E
HMV
HSV
2QV
3QV
SKH
Silencer
TotAirSys (Total Air)
TotAirSys (Gamma)
Ending

# 4KA4 Series

Discrete valve; body piping

## Dimensions

### 4KA410

● 2-position single: grommet lead wire

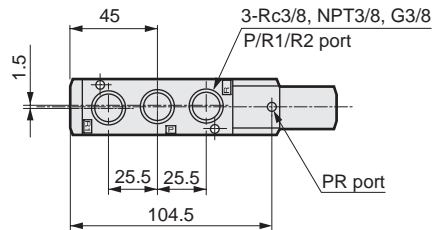
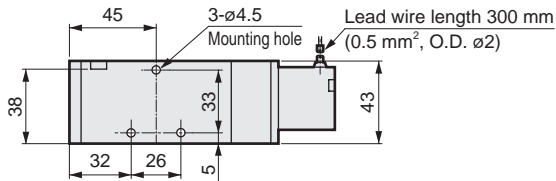
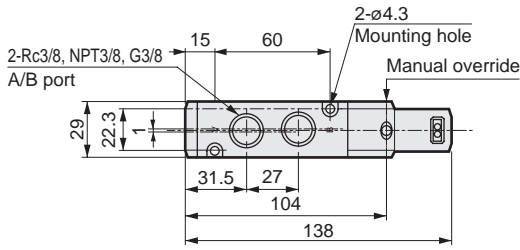

### 4KA420

● 2-position double: grommet lead wire

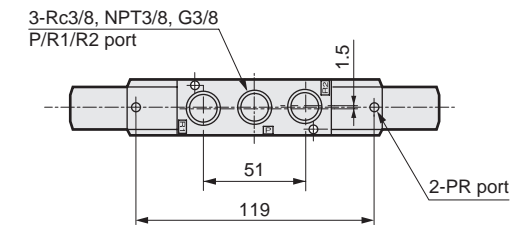
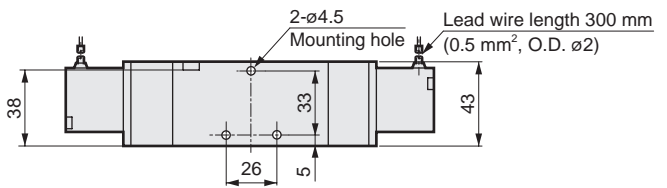
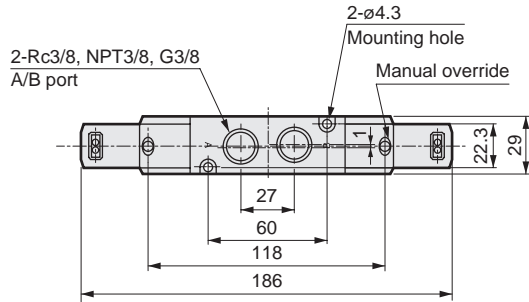

### 4KA440

● 3-position: grommet lead wire

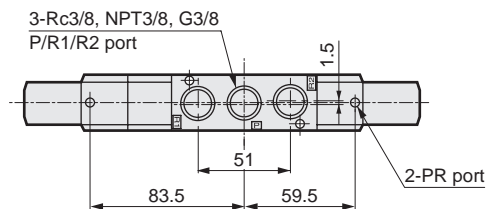
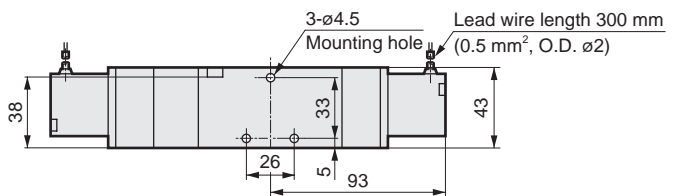
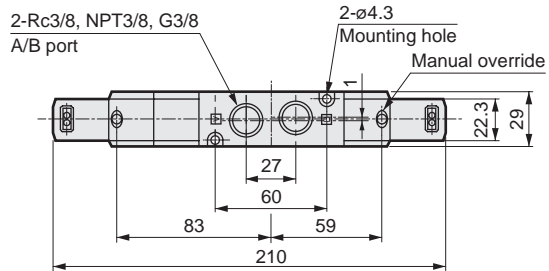

● Mounting plate: (P [2-position single only])

Material: Steel

Zinc chromate treatment

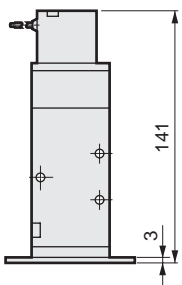
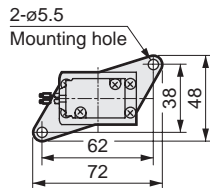

### Dimensions

● With  $\phi 10/\phi 12$  push-in fitting: (GS10\*/GS12\*)

● Terminal box: (B/L/LS)

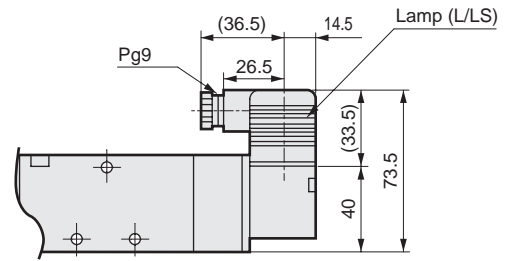
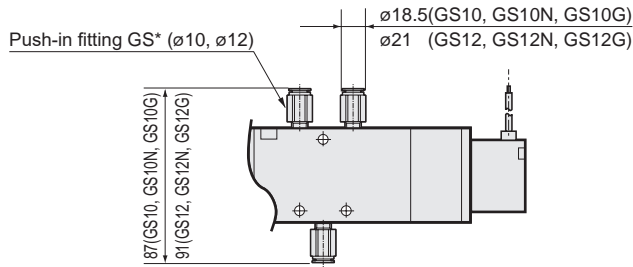

● C-connector: (C/C1/C0\*/C2/C2\*/C3)

● D-connector: (D/D1/D0\*/D2/D2\*/D3)

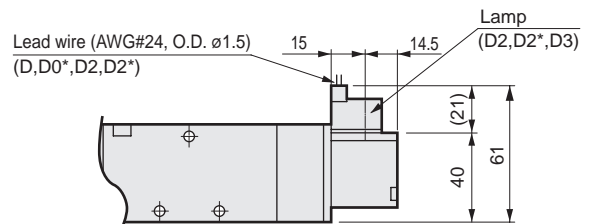
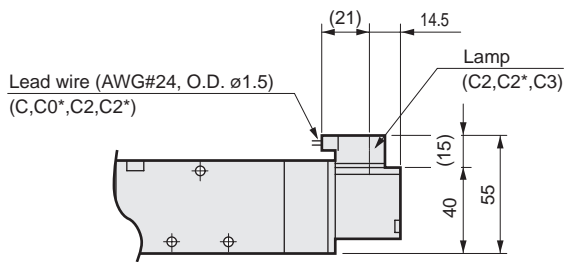

4GA/B
M4GA/B
MN4GA/B
4GA/B (master)
4GB With sensor
4GD/E
M4GD/E
MN4GD/E
4GA4/B4
MN3E
MN4E
W4GA/B2
W4GB4
MN3S0
MN4S0
4SA/B0
<b>4KA/B</b>
<b>4KA/B (master)</b>
4F
4F (master)
PV5G
GMF
PV5
GMF
PV5S-0
3Q
MV3QR
3MA/B0
3PA/B
P/M/B
NP/NAP
NVP
4G*0EJ
4F*0EX
4F*0E
HMV
HSV
2QV
3QV
SKH
Silencer
TotAirSys (Total Air)
TotAirSys (Gamma)
Ending

4GA/B  
M4GA/B  
MN4GA/B  
4GA/B (master)  
4GB With sensor  
4GD/E  
M4GD/E  
MN4GD/E  
4GA4/B4  
MN3E  
MN4E  
W4GA/B2  
W4GB4  
MN3S0  
MN4S0  
4SA/B0  
4KA/B  
4KA/B (master)  
4F  
4F (master)  
PV5G  
GMF  
PV5  
GMF  
PV5S-0  
3Q  
MV3QR  
3MA/B0  
3PA/B  
P/M/B  
NP/NAP  
NVP  
4G\*0EJ  
4F\*0EX  
4F\*0E  
HNV  
HSV  
2QV  
3QV  
SKH  
Silencer  
TotAirSys (Total Air)  
TotAirSys (Gamma)  
Ending



Discrete valve sub-plate piping  
Pilot operated 5-port pneumatic valve

# 4KB1/2/3/4 Series

● Cylinder bore size:  $\varnothing 20$  to  $\varnothing 160$

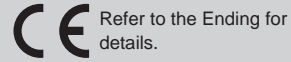

## JIS symbol

- 5-port valve  
2-position single

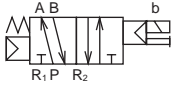

- 5-port valve  
2-position double

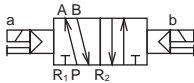

- 5-port valve  
3-position all ports closed

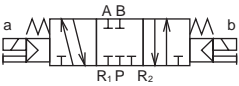

- 5-port valve  
3-position A/B/R connection

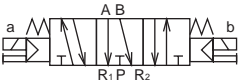

- 5-port valve  
3-position P/A/B connection



- External pilot

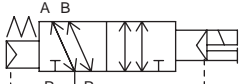

(2-position single)

## Common specifications

Item	Description
Valve and operation	Pilot operated soft spool valve
Working fluid	Compressed air
Max. working press. MPa	0.70 ( $\approx 100$ psi, 7 bar)
Min. working press. MPa	Refer to Individual specifications listed below
Proof pressure MPa	1.05 ( $\approx 150$ psi, 10.5 bar)
Ambient temperature $^{\circ}\text{C}$	-5 (23 $^{\circ}\text{F}$ ) to 50 (122 $^{\circ}\text{F}$ ) (no freezing)
Fluid temperature $^{\circ}\text{C}$	5 (41 $^{\circ}\text{F}$ ) to 50 (122 $^{\circ}\text{F}$ )
Lubrication	Not required
Degree of protection	Dust-proof
Vibration resistance $\text{m/s}^2$	50 or less
Shock resistance $\text{m/s}^2$	300 or less
Atmosphere	Cannot be used in corrosive gas environment.

\*1: The working pressure when the external pilot (option code: K) has been selected is 0 to 0.7 MPa.  
In addition, use the pilot with a pressure of 0.2 to 0.7 MPa.

## Electrical specifications

Item		4KB1/2	4KB3/4
Rated voltage	AC	100,200 ( 50 / 60 Hz )	
	DC	24	
Voltage fluctuation range		$\pm 10\%$	
Starting current	AC 100 V	0.056/0.044	0.046/0.042
	A AC 200 V	0.028/0.022	0.023/0.021
Holding current	AC 100 V	0.028/0.022	0.023/0.021
	A AC 200 V	0.014/0.011	
Power consumption	DC 24 V	0.075	
	AC 100 V	1.8 / 1.4 (1.8 / 1.5)	1.6 / 1.3 (1.8 / 1.5)
( ) : With indicator	AC 200 V	1.8 / 1.4 (1.8 / 1.5)	1.6 / 1.3 (1.8 / 1.5)
	DC 24 V	1.8(2.0)	
Thermal class		B (molded coil)	
Temperature rise $^{\circ}\text{C}$		43	30

Reference: 100 VAC 50/60 Hz can be used with a rated voltage of 110 VAC 60 Hz and 200 VAC 50/60 Hz can be used with 220 VAC 60 Hz.

## Individual specifications

1 MPa  $\approx$  145.0 psi, 1 MPa = 10 bar

Item			4KB1	4KB2	4KB3	4KB4
Min. working pressure	2-position	Single	0.15	0.15	0.15	0.15
		Double		0.10	0.10	0.10
	3-position		0.20	0.20	0.20	0.20
Port size	P/A/B port	Rc1/8	Rc1/8	Rc1/8, Rc1/4	Rc1/4, Rc3/8	Rc3/8, Rc1/2
		NPT1/8	NPT1/8, NPT1/4	NPT1/4, NPT3/8	NPT3/8, NPT1/2	
	G1/8	G1/8, G1/4	G1/4, G3/8	G3/8, G1/2		
	R1/R2 port	Rc1/8	Rc1/8, Rc1/4	Rc1/4, Rc3/8	Rc3/8, Rc1/2	
		NPT1/8	NPT1/8, NPT1/4	NPT1/4, NPT3/8	NPT3/8, NPT1/2	
		G1/8	G1/8, G1/4	G1/4, G3/8	G3/8, G1/2	

## Performance/characteristics by model

Item		4KB1	4KB2	4KB3	4KB4
Response time	2-position	30 or less	30 or less	30 or less	30 or less
	*1 ms 3-position	60 or less	60 or less	60 or less	60 or less

\*1: The response time is the value at 0.5 MPa working pressure, with no lubrication, and with the power ON. It depends on the pressure and the lubricant quality.

## Weight

Item			4KB1	4KB2	4KB3	4KB4
Weight	g	2-position Single	104	200	353	579
		Double	144	240	454	689
	3-position	154	255	493	759	

## Flow characteristics

Model No.	Solenoid position	C [dm <sup>3</sup> / (s·bar)]	b	
4KB1	2-position	0.89	0.44	
	3-position	All ports closed	0.63	0.50
		A/B/R connection	1.2	0.29
		P/A/B connection	0.75	0.39
4KB2	2-position	2.7	0.24	
	3-position	All ports closed	2.4	0.29
		A/B/R connection	3.0	0.27
		P/A/B connection	2.4	0.34
4KB3	2-position	6.3	0.26	
	3-position	All ports closed	5.6	0.27
		A/B/R connection	6.6	0.20
		P/A/B connection	5.9	0.27
4KB4	2-position	12	0.24	
	3-position	All ports closed	11	0.27
		A/B/R connection	13	0.21
		P/A/B connection	10	0.22

\*1: Effective cross-sectional area S and sonic conductance C are converted as  $S \approx 5.0 \times C$ .

### Ozone-proof specifications (Ending Page 5)

\*\* - Voltage - **P11**

### Copper and PTFE free specifications

● Copper- and PTFE-based materials are not used in the flow path.

\*\* - Voltage - **P6**

### CE marking specifications

\*\* - Voltage - **ST**

• Standard voltage of 24 VDC or less is CE marking-compatible even if the model No. is not indicated with "ST".

4GA/B
M4GA/B
MN4GA/B
4GA/B (master)
4GB With sensor
4GD/E
M4GD/E
MN4GD/E
4GA4/B4
MN3E
MN4E
W4GA/B2
W4GB4
MN3S0
MN4S0
4SA/B0
<b>4KA/B</b>
4KA/B (master)
4F
4F (master)
PV5G
GMF
PV5
GMF
PV5S-0
3Q
MV3QR
3MA/B0
3PA/B
P/M/B
NP/NAP
NVP
4G*0EJ
4F*0EX
4F*0E
HMV
HSV
2QV
3QV
SKH
Silencer
TotAirSys (Total Air)
TotAirSys (Gamma)
Ending



# 4KB1 to 4 Series

Discrete valve; sub-plate piping

## How to order

**4KB2** **1** **0** - **06** - **M1** **B** - **AC100V**

● Single solenoid valve for manifold

**4KB1** **1** **9** - **00** - **M1** **B** - **AC100V**

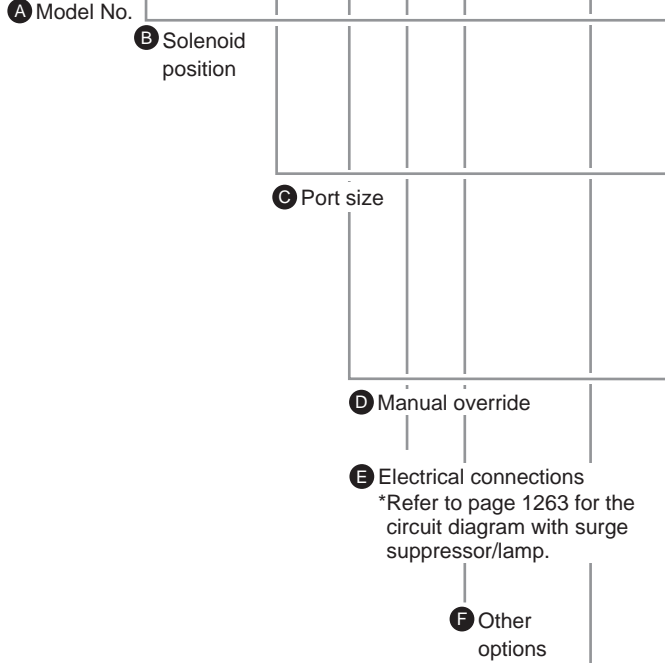

\* Gasket/mounting screw included

### A Model No.

4KB1	4KB2	4KB3	4KB4
------	------	------	------

Code	Description	4KB1	4KB2	4KB3	4KB4
<b>B</b> 1	2-position single	●	●	●	●
2	2-position double	●	●	●	●
3	3-position all ports closed	●	●	●	●
4	3-position A/B/R connection	●	●	●	●
5	3-position P/A/B connection	●	●	●	●

Port size	Port	Port P/A/B	Port R1/R2			
			(1) = Rc1/8	(2) = Rc1/4	(3) = Rc3/8	(4) = Rc1/2
<b>C</b>	06	Rc1/8	(1)	(2)		
	08	Rc1/4		(2)	(2)	
	10	Rc3/8			(3)	(3)
	15	Rc1/2				(4)
<b>C</b>	Port	Port P/A/B	Port R1/R2			
			(5) = NPT1/8	(6) = NPT1/4	(7) = NPT3/8	(8) = NPT1/2
	06N	NPT1/8	(5)	(6)		
	08N	NPT1/4		(6)	(6)	
	10N	NPT3/8			(7)	(7)
15N	NPT1/2				(8)	
<b>C</b>	Port	Port P/A/B	Port R1/R2			
			(9) = G1/8	(10) = G1/4	(11) = G3/8	(12) = G1/2
	06G	G1/8	(9)	(10)		
	08G	G1/4		(10)	(10)	
	10G	G3/8			(11)	(11)
15G	G1/2				(12)	

D	Description	4KB1	4KB2	4KB3	4KB4
Blank	Non-locking manual override	●	●	●	●
M1	Locking manual override	●	●	●	●

E Refer to the electrical connections list on the next page.

F	Description	4KB1	4KB2	4KB3	4KB4
Blank	No option	●	●	●	●
K	External pilot (*2)	●	●	●	●
S	Surge suppressor included (*3) (*4)	●	●	●	●
-A	Coolant supported (packing: FKM)	●	●	●	●

Voltage	Code	Description	Standard			
			4KB1	4KB2	4KB3	4KB4
<b>G</b>	AC100V	100 VAC 50/60 Hz	●	●	●	●
	AC200V	200 VAC 50/60 Hz	●	●	●	●
	DC24V	24 VDC	●	●	●	●
	DC12V	12 VDC	●	●	●	●
	AC110V	110 VAC 50/60 Hz	●	●	●	●
	AC220V	220 VAC 50/60 Hz	●	●	●	●
<b>G</b>		Option				

* Other made-to-order products					
AC24V		●	●	●	●
AC115V		●	●	●	●
AC120V		●	●	●	●

[Table 1] Compact terminal box L/LS compatibility table

Code	Description	4KB1	4KB2	4KB3	4KB4	Surge suppressor		
L	Without lead wire	With indicator lamp	AC	●	●	●	●	
		DC			●	●		
	With surge suppressor and indicator lamp	AC						
		DC	●	●				Integrated
LS	Without lead wire	With surge suppressor and indicator lamp	AC	●	●	●	●	Integrated
		DC			●	●		Integrated

### ⚠ Precautions for model No. selection

- \*1: The DC voltage models of the compact terminal box "L" of 4KB1, 4KB2 are equipped with a surge suppressor.
- \*2: Consult with CKD when using a vacuum with the external pilot (K).
- \*3: The surge suppressor for attachment is a suppression connector when the grommet lead wire is 24 VDC or less. (Refer to page 1262.)
- \*4: The surge suppressor can only be selected when the grommet lead wire or compact terminal box "B" has been selected for the electrical connections.

### [Example of model No.]

**4KB210-06-M1BK-AC100V**

- A** Model : 4KB2
- B** Solenoid position : 2-position single
- C** Port size : Rc1/8
- D** Manual override : Locking manual override
- E** Electrical connections : Compact terminal box/ without lead wire
- F** Other options : External pilot
- G** Voltage : 100 VAC 50/60 Hz

**G** Voltage

[Electrical connections list]

		A Model No.				
		4KB1	4KB2	4KB3	4KB4	
Code	Description					
E	Grommet lead wire					
	Blank	Grommet lead wire (300 mm)	●	●	●	●
	Compact terminal box					
	B	Without lead wire	●	●	●	●
	L	Without lead wire	Refer to [Table 1] on the previous page for details (*1)			
	LS	Without lead wire, with surge suppressor/lamp				
	C-connector (lead wire lateral direction)					
	C	Lead wire length (300 mm)	●	●	●	●
	C00	Lead wire length (500 mm)	●	●	●	●
	C01	Lead wire length (1000 mm)	●	●	●	●
	C02	Lead wire length (2000 mm)	●	●	●	●
	C03	Lead wire length (3000 mm)	●	●	●	●
	C1	Without lead wire	●	●	●	●
	C2	Lead wire length (300 mm) with surge suppressor/lamp	●	●	●	●
	C20	Lead wire length (500 mm) with surge suppressor/lamp	●	●	●	●
	C21	Lead wire length (1000 mm) with surge suppressor/lamp	●	●	●	●
	C22	Lead wire length (2000 mm) with surge suppressor/lamp	●	●	●	●
	C23	Lead wire length (3000 mm) with surge suppressor/lamp	●	●	●	●
	C3	Without lead wire, with surge suppressor/lamp	●	●	●	●
	D-connector (lead wire upward direction)					
	D	Lead wire length (300 mm)	●	●	●	●
	D00	Lead wire length (500 mm)	●	●	●	●
	D01	Lead wire length (1000 mm)	●	●	●	●
	D02	Lead wire length (2000 mm)	●	●	●	●
	D03	Lead wire length (3000 mm)	●	●	●	●
	D1	Without lead wire	●	●	●	●
	D2	Lead wire length (300 mm) with surge suppressor/lamp	●	●	●	●
	D20	Lead wire length (500 mm) with surge suppressor/lamp	●	●	●	●
	D21	Lead wire length (1000 mm) with surge suppressor/lamp	●	●	●	●
	D22	Lead wire length (2000 mm) with surge suppressor/lamp	●	●	●	●
	D23	Lead wire length (3000 mm) with surge suppressor/lamp	●	●	●	●
	D3	Without lead wire, with surge suppressor/lamp	●	●	●	●

4GA/B
M4GA/B
MN4GA/B
4GA/B (master)
4GB With sensor
4GD/E
M4GD/E
MN4GD/E
4GA4/B4
MN3E MN4E
W4GA/B2
W4GB4
MN3S0 MN4S0
4SA/B0
<b>4KA/B</b>
4KA/B (master)
4F
4F (master)
PV5G GMF
PV5 GMF
PV5S-0
3Q
MV3QR
3MA/B0
3PA/B
P/M/B
NP/NAP NVP
4G*0EJ
4F*0EX
4F*0E
HMV HSV
2QV 3QV
SKH
Silencer
TotAirSys (Total Air)
TotAirSys (Gamma)
Ending

# 4KB1 Series

Discrete valve; sub-plate piping

## Internal structure and parts list

- 4GA/B
- M4GA/B
- MN4GA/B
- 4GA/B (master)
- 4GB With sensor
- 4GD/E
- M4GD/E
- MN4GD/E
- 4GA4/B4
- MN3E
- MN4E
- W4GA/B2
- W4GB4
- MN3S0
- MN4S0
- 4SA/B0
- 4KA/B
- 4KA/B (master)
- 4F
- 4F (master)
- PV5G
- GMF
- PV5
- GMF
- PV5S-0
- 3Q
- MV3QR
- 3MA/B0
- 3PA/B
- P/M/B
- NP/NAP
- NVP
- 4G\*0EJ
- 4F\*0EX
- 4F\*0E
- HMV
- HSV
- 2QV
- 3QV
- SKH
- Silencer
- TotAirSys (Total Air)
- TotAirSys (Gamma)
- Ending

### 4KB110

● 2-position single

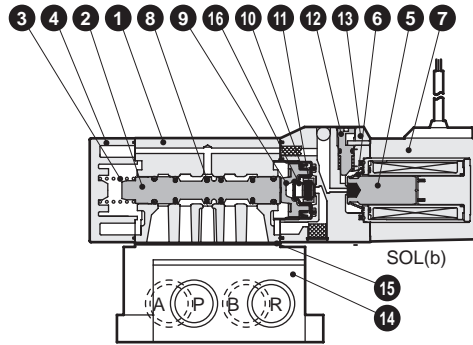
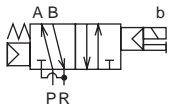

### 4KB120

● 2-position double

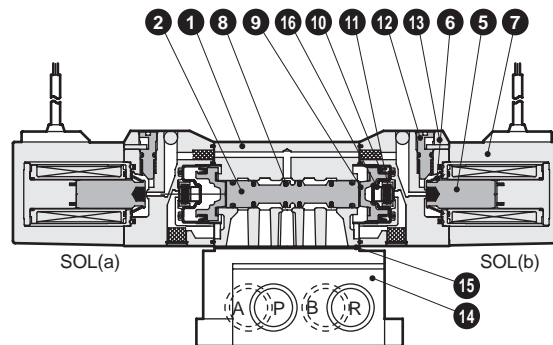
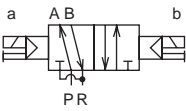

### 4KB130

● 3-position all ports closed

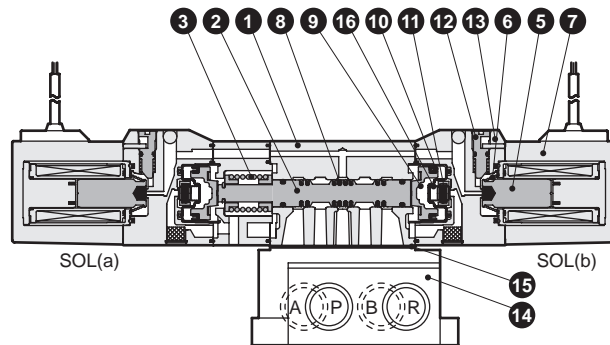
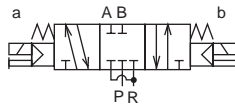

### 4KB140

● 3-position A/B/R connection

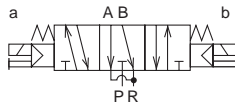

### 4KB150

● 3-position P/A/B connection

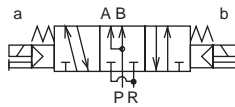

## Main parts list

No.	Part name	Material
1	Body	Aluminum alloy die-casting
2	Valving element (spool)	Aluminum
3	Valve spring	Stainless steel
4	Cap	Resin
5	Plunger	-
6	Plunger spring	-
7	Coil assembly	-
8	Spool packing	Nitrile rubber
9	Piston	Resin
10	Piston packing	Nitrile rubber
11	Valve seat	Nitrile rubber
12	Manual button	Resin
13	Pilot valve	Resin
14	Sub-plate	Aluminum alloy die-casting
15	Gasket	*2 Nitrile rubber
16	Valve seat spring	Stainless steel

## Main parts list

No.	Component name	Model No.
14	Sub-plate kit	4KB110- <b>E</b> Port size - <b>F</b> Exterior Pilot -SUB-BASE-KIT
15		

\* Mounting screws are attached to the sub-plate kit.

## Repair parts list

No./part name	2 8	9 10	5 6 7
Model No.	Spool assembly	Piston assembly	Coil assembly *
4KB110	4K9-110	4K9-151	4K1L- <b>E</b> electrical connection option code - Blank for grommet lead wire
4KB120	4K9-118		
4KB130	4K9-111	4K9-152	COIL - <b>G</b> Voltage
4KB140	4K9-112		
4KB150	4K9-113		

\*1: The compact terminal box and connector of the coil assembly will come assembled and attached with the options of the descriptions indicated with model No. selection.

\*2: Take care, as gasket **15** mounting has an orientation.

## Internal structure and parts list

### 4KB210

● 2-position single

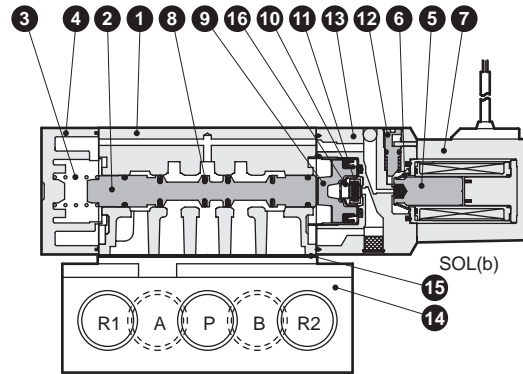
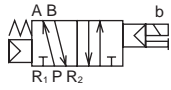

### 4KB220

● 2-position double

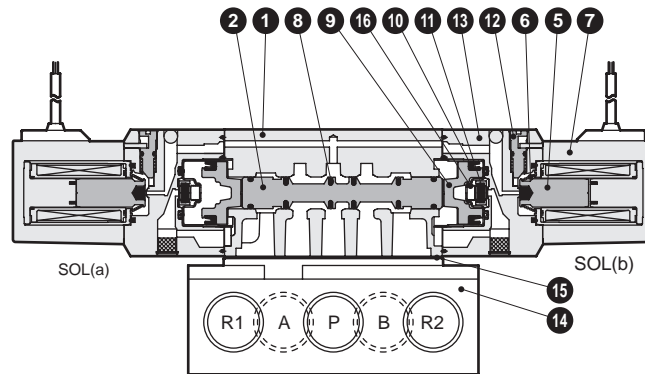
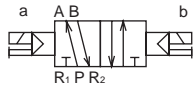

### 4KB230

● 3-position all ports closed

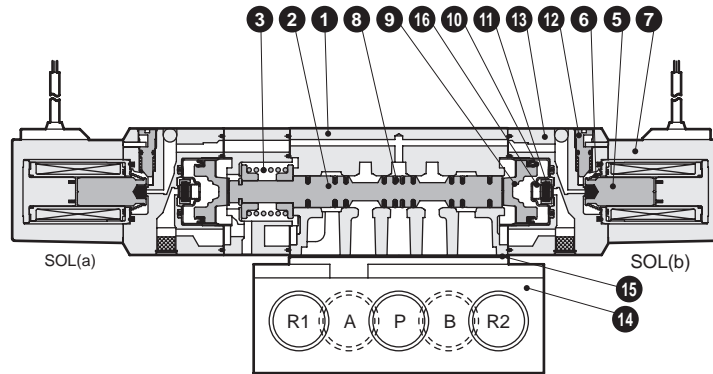

### 4KB240

● 3-position A/B/R connection



### 4KB250

● 3-position P/A/B connection



## Main parts list

No.	Part name	Material
1	Body	Aluminum alloy die-casting
2	Valving element (spool)	Aluminum
3	Valve spring	Stainless steel
4	Cap	Resin
5	Plunger	-
6	Plunger spring	-
7	Coil assembly	-
8	Spool packing	Nitrile rubber
9	Piston	Resin
10	Piston packing	Nitrile rubber
11	Valve seat	Nitrile rubber
12	Manual button	Resin
13	Pilot valve	Resin
14	Sub-plate	Aluminum alloy die-casting
15	Gasket	Nitrile rubber
16	Valve seat spring	Stainless steel

## Main parts list

No.	Component name	Model No.
14	Sub-plate kit	4KB210- <b>B</b> Port size - <b>F</b> Exterior Pilot -SUB-BASE-KIT
15		

\* Mounting screws are attached to the sub-plate kit.

## Repair parts list

No./part name	2 8	9 10	5 6 7
Model No.	Spool assembly	Piston assembly	Coil assembly *
4KB210	4K9-150	4K9-153	4K1L- <b>E</b> electrical connection option code Blank for grommet lead wire
4KB220	4K9-126		
4KB230	4K9-127	4K9-154	
4KB240	4K9-128		
4KB250	4K9-129		COIL - <b>G</b> Voltage

\*1: The compact terminal box and connector of the coil assembly will come assembled and attached with the options of the descriptions indicated with model No. selection.

- 4GA/B
- M4GA/B
- MN4GA/B
- 4GA/B (master)
- 4GB With sensor
- 4GD/E
- M4GD/E
- MN4GD/E
- 4GA4/B4
- MN3E MN4E
- W4GA/B2
- W4GB4
- MN3S0 MN4S0
- 4SA/B0
- 4KA/B**
- 4KA/B (master)
- 4F
- 4F (master)
- PV5G GMF
- PV5 GMF
- PV5S-0
- 3Q
- MV3QR
- 3MA/B0
- 3PA/B
- P/M/B
- NP/NAP NVP
- 4G\*0EJ
- 4F\*0EX
- 4F\*0E
- HMV HSV
- 2QV 3QV
- SKH
- Silencer
- TotAirSys (Total Air)
- TotAirSys (Gamma)
- Ending

# 4KB3 Series

Discrete valve; sub-plate piping

## Internal structure and parts list

- 4GA/B
- M4GA/B
- MN4GA/B
- 4GA/B (master)
- 4GB With sensor
- 4GD/E
- M4GD/E
- MN4GD/E
- 4GA4/B4
- MN3E
- MN4E
- W4GA/B2
- W4GB4
- MN3S0
- MN4S0
- 4SA/B0
- 4KA/B
- 4KA/B (master)
- 4F
- 4F (master)
- PV5G
- GMF
- PV5
- GMF
- PV5S-0
- 3Q
- MV3QR
- 3MA/B0
- 3PA/B
- P/M/B
- NP/NAP
- NVP
- 4G\*0EJ
- 4F\*0EX
- 4F\*0E
- HMV
- HSV
- 2QV
- 3QV
- SKH
- Silencer
- TotAirSys (Total Air)
- TotAirSys (Gamma)
- Ending

### 4KB310

● 2-position single

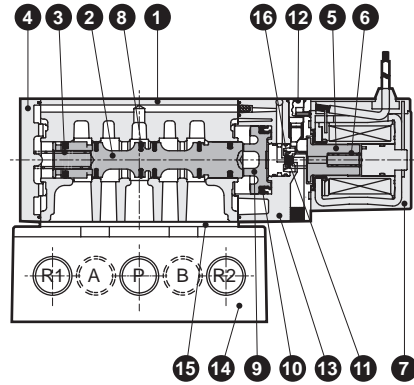
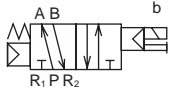

### 4KB320

● 2-position double

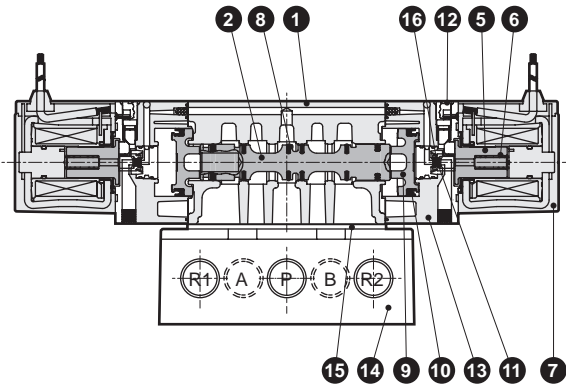
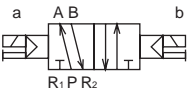

### 4KB330

● 3-position all ports closed

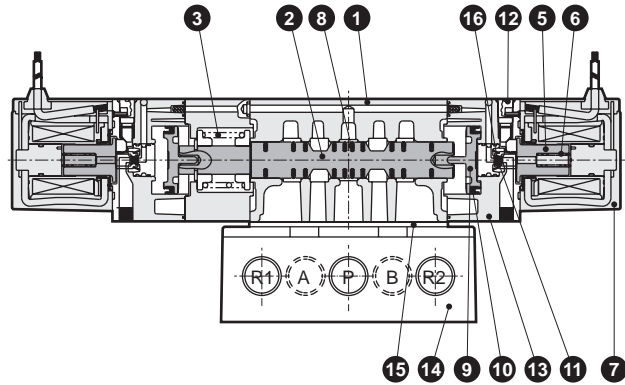
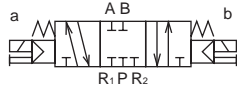

### 4KB340

● 3-position A/B/R connection



### 4KB350

● 3-position P/A/B connection



## Main parts list

No.	Part name	Material
1	Body	Aluminum alloy die-casting
2	Valving element (spool)	Aluminum
3	Valve spring	Stainless steel
4	Cap	Resin
5	Plunger	-
6	Plunger spring	-
7	Coil assembly	-
8	Spool packing	Nitrile rubber
9	Piston	Resin
10	Piston packing	Nitrile rubber
11	Valve seat	Nitrile rubber
12	Manual button	Resin
13	Pilot valve	Resin
14	Sub-plate	Aluminum alloy die-casting
15	Gasket	*2 Nitrile rubber
16	Valve seat spring	Stainless steel

## Main parts list

No.	Component name	Model No.
14	Sub-plate kit	4KB310- <b>E</b> Port size - <b>F</b> External pilot -SUB-BASE-KIT

\* Mounting screws are attached to the sub-plate kit.

## Repair parts list

No./part name	2 8	9 10	5 6 7
Model No.	Spool assembly	Piston assembly	Coil assembly *1
4KB310	4K9-133	4K9-137	4K3- <b>E</b> electrical connection option code - Blank for grommet lead wire COIL - <b>G</b> Voltage
4KB320			
4KB330	4K9-134	4K9-138	
4KB340			
4KB350	4K9-135	4K9-136	

\* 1: The terminal box and connector of the coil assembly will come assembled and included with the options of the descriptions indicated with model No. selection.

\* 2: Take care, as gasket **15** mounting has an orientation.

## Internal structure and parts list

### 4KB410

● 2-position single

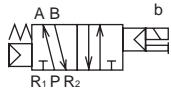

### 4KB420

● 2-position double

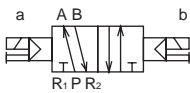

### 4KB430

● 3-position all ports closed



### 4KB440

● 3-position A/B/R connection



### 4KB450

● 3-position P/A/B connection



## Main parts list

No.	Part name	Material
1	Body	Aluminum alloy die-casting
2	Valving element (spool)	Aluminum
3	Valve spring	Stainless steel
4	Cap	Resin
5	Plunger	-
6	Plunger spring	-
7	Coil assembly	-
8	Spool packing	Nitrile rubber
9	Piston	Resin
10	Piston packing	Nitrile rubber
11	Valve seat	Nitrile rubber
12	Manual button	Resin
13	Pilot valve	Resin
14	Sub-plate	Aluminum alloy die-casting
15	Gasket	Nitrile rubber
16	Valve seat spring	Stainless steel

## Main parts list

No.	Component name	Model No.
14	Sub-plate kit	4KB410- <b>B</b> Port size - <b>F</b> External pilot -SUB-BASE-KIT
15		

\* Mounting screws are attached to the sub-plate kit.

## Repair parts list

No./part name	2 8	9 10	5 6 7
Model No.	Spool assembly	Piston assembly	Coil assembly *
4KB410	4K9-140	4K9-144	4K3- <b>E</b> electrical connection option code - Blank for grommet lead wire
4KB420			
4KB430	4K9-141	4K9-145	COIL - <b>G</b> Voltage
4KB440			
4KB450	4K9-143		

\* 1: The plunger assembly is attached with the coil assembly. As there are limitations with the combinations of coils and plungers, do not replace these.

\* 2: The terminal box and connector of the coil assembly will come assembled and included with the options of the descriptions indicated with model No. selection.

\* 3: When combining a coil assembly into a valve, contact CKD for precautions regarding the work.

- 4GA/B
- M4GA/B
- MN4GA/B
- 4GA/B (master)
- 4GB With sensor
- 4GD/E
- M4GD/E
- MN4GD/E
- 4GA4/B4
- MN3E MN4E
- W4GA/B2
- W4GB4
- MN3S0 MN4S0
- 4SA/B0
- 4KA/B**
- 4KA/B (master)**
- 4F
- 4F (master)
- PV5G GMF
- PV5 GMF
- PV5S-0
- 3Q
- MV3QR
- 3MA/B0
- 3PA/B
- P/M/B
- NP/NAP NVP
- 4G\*0EJ
- 4F\*0EX
- 4F\*0E
- HMV HSV
- 2QV 3QV
- SKH
- Silencer
- TotAirSys (Total Air)
- TotAirSys (Gamma)
- Ending



# 4KB1 Series

Discrete valve; sub-plate piping

Dimensions



- 4GA/B
- M4GA/B
- MN4GA/B
- 4GA/B (master)
- 4GB With sensor
- 4GD/E
- M4GD/E
- MN4GD/E
- 4GA4/B4
- MN3E
- MN4E
- W4GA/B2
- W4GB4
- MN3S0
- MN4S0
- 4SA/B0
- 4KA/B**
- 4KA/B (master)
- 4F
- 4F (master)
- PV5G
- GMF
- PV5
- GMF
- PV5S-0
- 3Q
- MV3QR
- 3MA/B0
- 3PA/B
- P/M/B
- NP/NAP
- NVP
- 4G\*0EJ
- 4F\*0EX
- 4F\*0E
- HMV
- HSV
- 2QV
- 3QV
- SKH
- Silencer
- TotAirSys (Total Air)
- TotAirSys (Gamma)
- Ending

## 4KB110

● 2-position single: grommet lead wire

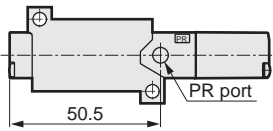
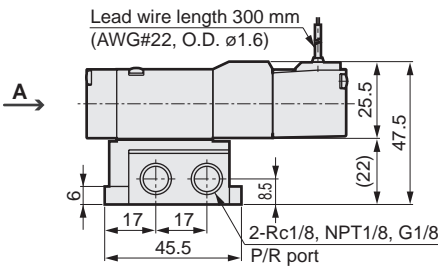
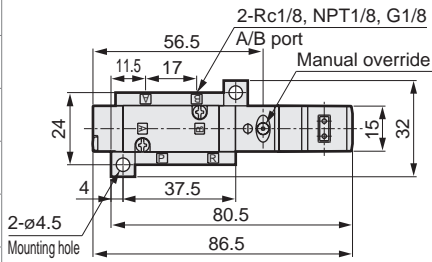

## 4KB120

● 2-position double: grommet lead wire

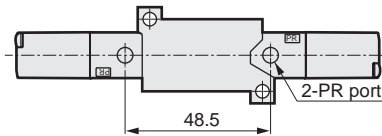
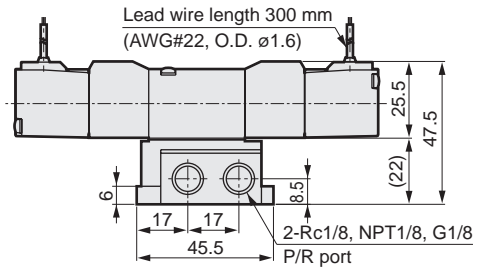
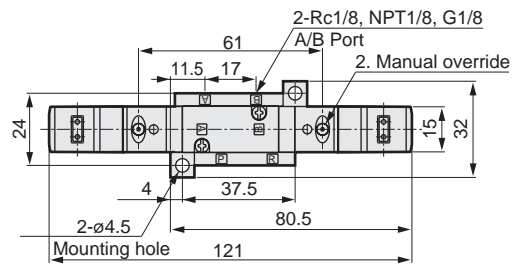

## 4KB140

● 3-position: grommet lead wire

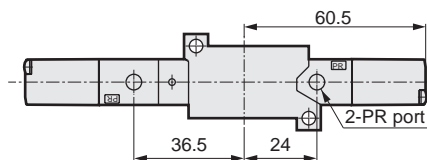
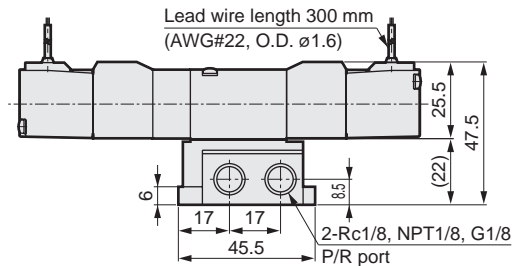
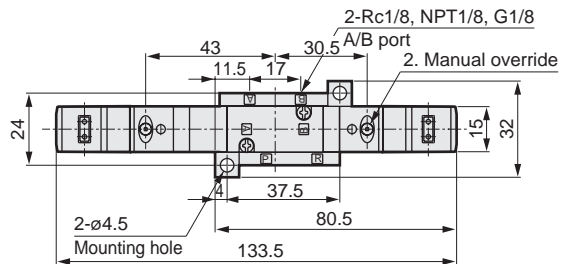

## Dimensions

- Compact terminal box: (B [Without lamp]/L/LS [With lamp])

Without indicator lamp

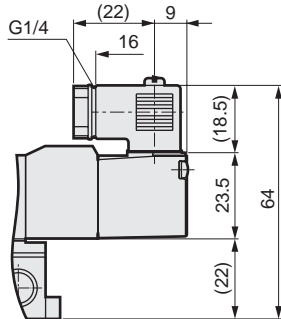

With indicator lamp

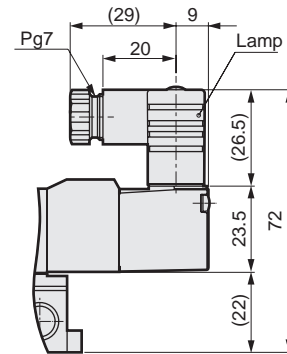

- C-connector: (C/C1/C0\*/C2/C2\*/C3)

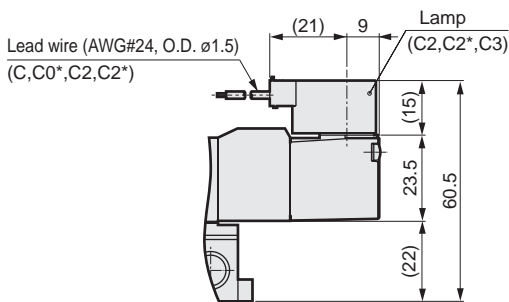

- D-connector: (D/D1/D0\*/D2/D2\*/D3)

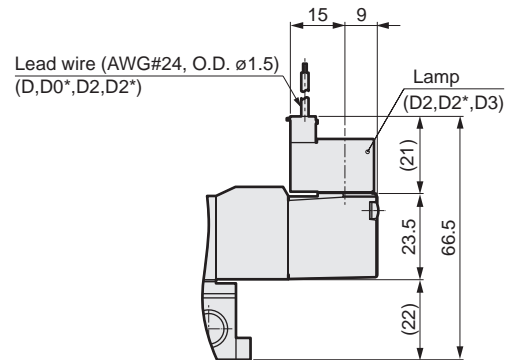

- External pilot: (K)

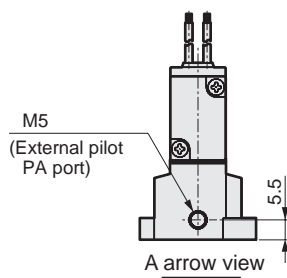

4GA/B
M4GA/B
MN4GA/B
4GA/B (master)
4GB With sensor
4GD/E
M4GD/E
MN4GD/E
4GA4/B4
MN3E
MN4E
W4GA/B2
W4GB4
MN3S0
MN4S0
4SA/B0
<b>4KA/B</b>
<b>4KA/B (master)</b>
4F
4F (master)
PV5G
GMF
PV5
GMF
PV5S-0
3Q
MV3QR
3MA/B0
3PA/B
P/M/B
NP/NAP
NVP
4G*0EJ
4F*0EX
4F*0E
HMV
HSV
2QV
3QV
SKH
Silencer
TotAirSys (Total Air)
TotAirSys (Gamma)
Ending

# 4KB2 Series

Discrete valve; sub-plate piping

## Dimensions



- 4GA/B
- M4GA/B
- MN4GA/B
- 4GA/B (master)
- 4GB With sensor
- 4GD/E
- M4GD/E
- MN4GD/E
- 4GA4/B4
- MN3E
- MN4E
- W4GA/B2
- W4GB4
- MN3S0
- MN4S0
- 4SA/B0
- 4KA/B**
- 4KA/B (master)
- 4F
- 4F (master)
- PV5G
- GMF
- PV5
- GMF
- PV5S-0
- 3Q
- MV3QR
- 3MA/B0
- 3PA/B
- P/M/B
- NP/NAP
- NVP
- 4G\*0EJ
- 4F\*0EX
- 4F\*0E
- HMV
- HSV
- 2QV
- 3QV
- SKH
- Silencer
- TotAirSys (Total Air)
- TotAirSys (Gamma)
- Ending

### 4KB210

● 2-position single: grommet lead wire

2-Rc1/8, 1/4  
NPT1/8, 1/4  
G1/8, 1/4  
A/B port

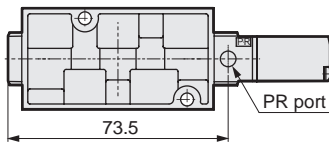
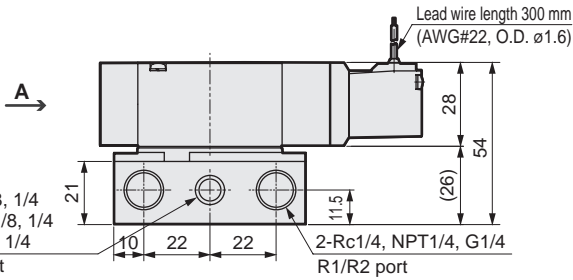
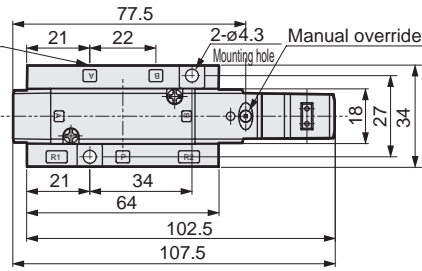

### 4KB220

● 2-position double: grommet lead wire

2-Rc1/8, 1/4  
NPT1/8, 1/4  
G1/8, 1/4  
A/B port

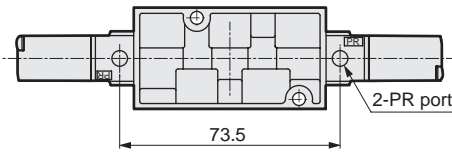
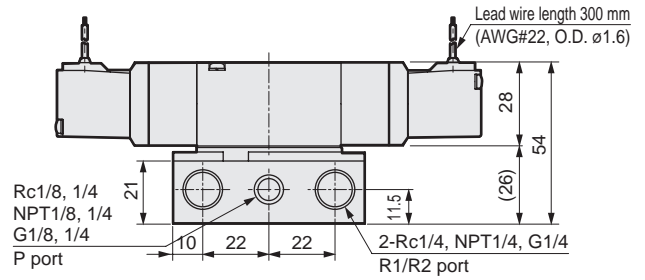
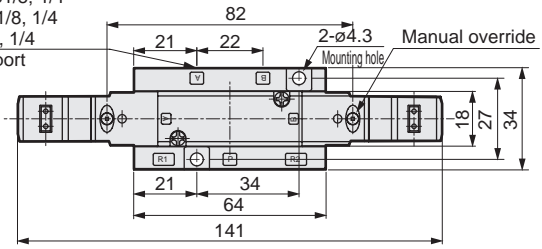

### 4KB250

● 3-position: grommet lead wire

2-Rc1/8, 1/4  
NPT1/8, 1/4  
G1/8, 1/4  
A/B port

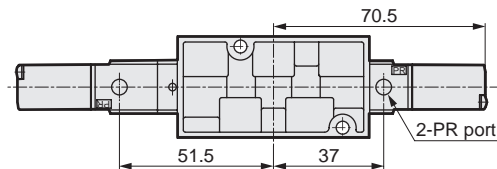
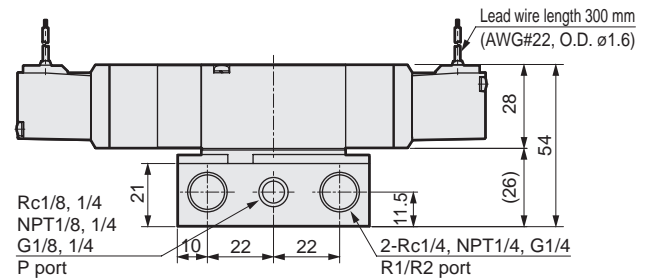
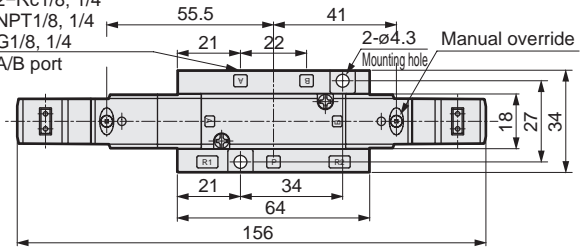

## Dimensions

- Compact terminal box: (B [Without lamp]/L/LS [With lamp])

Without indicator lamp

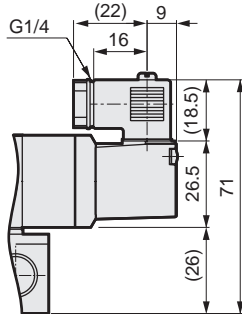

With indicator lamp

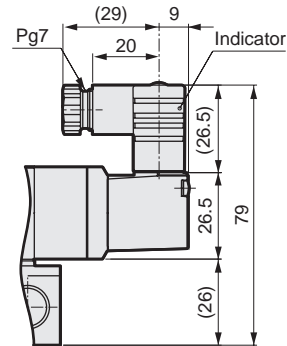

- C-connector: (C/C1/C0\*/C2/C2\*/C3)

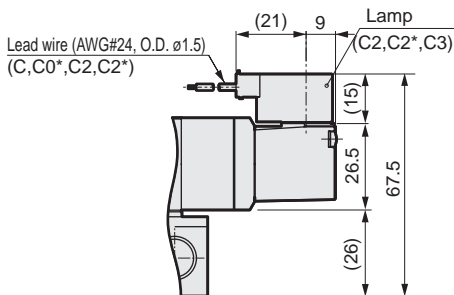

- D-connector: (D/D1/D0\*/D2/D2\*/D3)

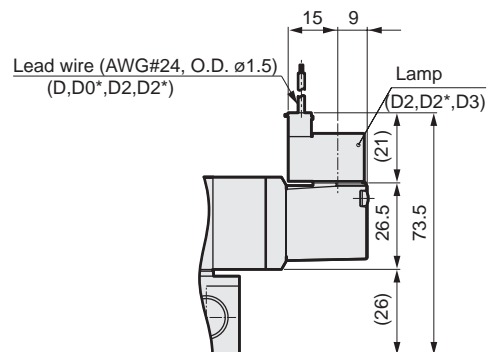

- External pilot: (K)

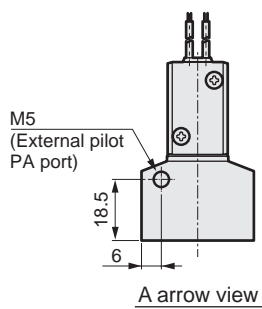

4GA/B
M4GA/B
MN4GA/B
4GA/B (master)
4GB With sensor
4GD/E
M4GD/E
MN4GD/E
4GA4/B4
MN3E
MN4E
W4GA/B2
W4GB4
MN3S0
MN4S0
4SA/B0
<b>4KA/B</b>
4KA/B (master)
4F
4F (master)
PV5G
GMF
PV5
GMF
PV5S-0
3Q
MV3QR
3MA/B0
3PA/B
P/M/B
NP/NAP
NVP
4G*0EJ
4F*0EX
4F*0E
HMV
HSV
2QV
3QV
SKH
Silencer
TotAirSys (Total Air)
TotAirSys (Gamma)
Ending

# 4KB3 Series

Discrete valve; sub-plate piping

Dimensions 

4GA/B
M4GA/B
MN4GA/B
4GA/B (master)
4GB With sensor
4GD/E
M4GD/E
MN4GD/E
4GA4/B4
MN3E
MN4E
W4GA/B2
W4GB4
MN3S0
MN4S0
4SA/B0
<b>4KA/B</b>
4KA/B (master)
4F
4F (master)
PV5G
GMF
PV5
GMF
PV5S-0
3Q
MV3QR
3MA/B0
3PA/B
P/M/B
NP/NAP
NVP
4G*0EJ
4F*0EX
4F*0E
HMV
HSV
2QV
3QV
SKH
Silencer
TotAirSys (Total Air)
TotAirSys (Gamma)
Ending

## 4KB310

● 2-position single: grommet lead wire

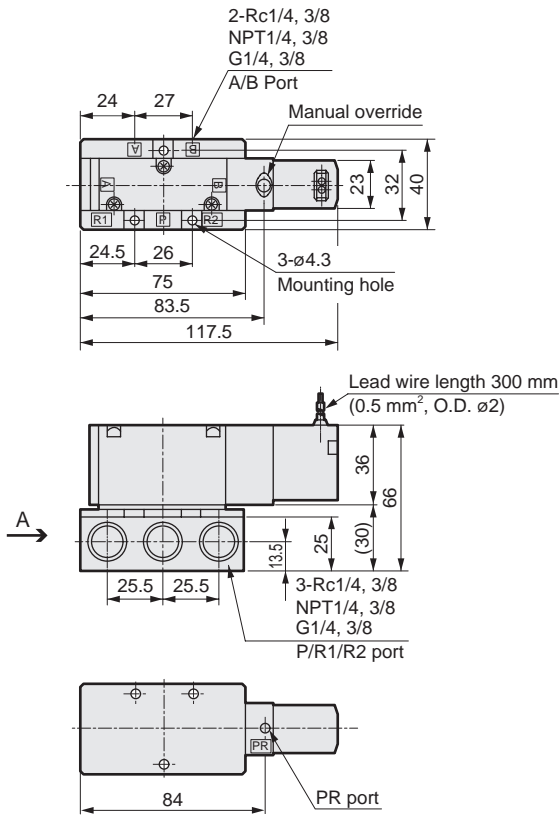

## 4KB320

● 2-position double: grommet lead wire

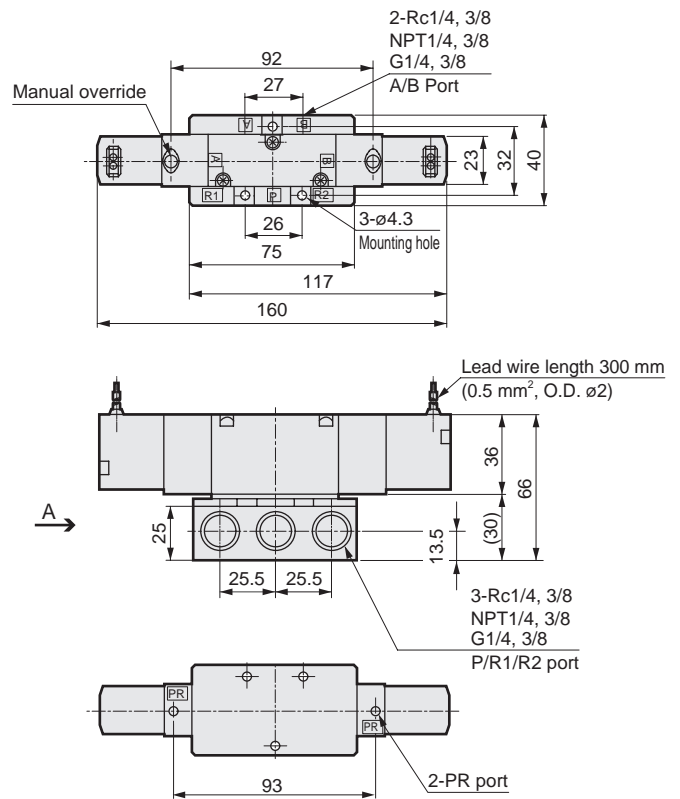

## 4KB340<sup>3</sup>/<sub>5</sub>

● 3-position: grommet lead wire

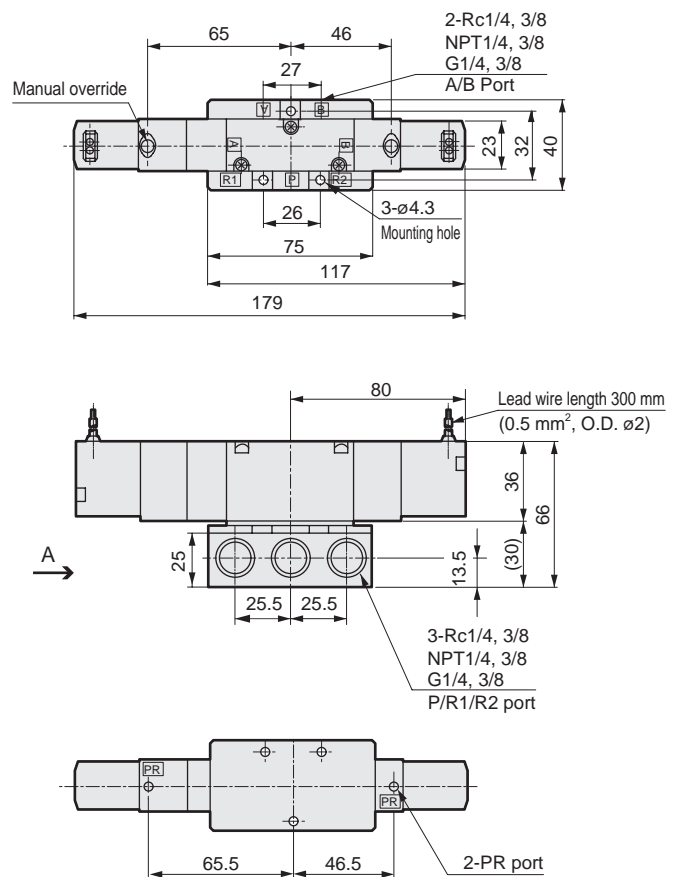

### Dimensions

● Terminal box: (B/L/LS)

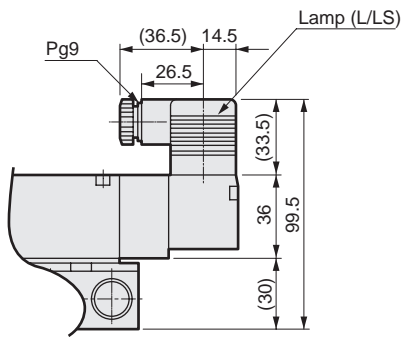

● C-connector: (C/C1/C0\*/C2/C2\*/C3)

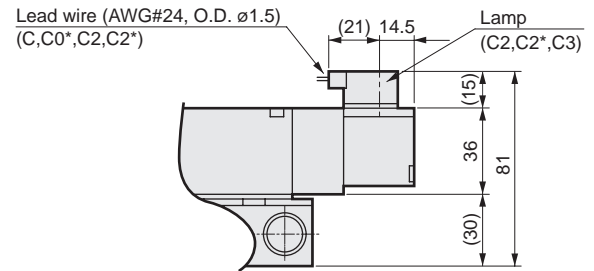

● D-connector: (D/D1/D0\*/D2/D2\*/D3)

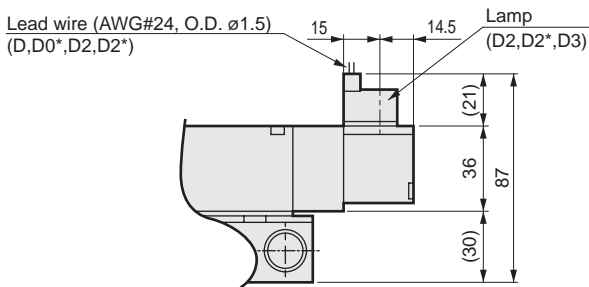

● External pilot: (K)

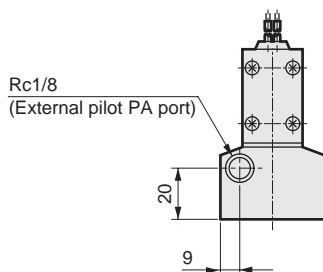

A arrow view

4GA/B
M4GA/B
MN4GA/B
4GA/B (master)
4GB With sensor
4GD/E
M4GD/E
MN4GD/E
4GA4/B4
MN3E
MN4E
W4GA/B2
W4GB4
MN3S0
MN4S0
4SA/B0
<b>4KA/B</b>
<b>4KA/B (master)</b>
4F
4F (master)
PV5G
GMF
PV5
GMF
PV5S-0
3Q
MV3QR
3MA/B0
3PA/B
P/M/B
NP/NAP
NVP
4G*0EJ
4F*0EX
4F*0E
HMV
HSV
2QV
3QV
SKH
Silencer
TotAirSys (Total Air)
TotAirSys (Gamma)
Ending



# 4KB4 Series

Discrete valve; sub-plate piping

## Dimensions



- 4GA/B
- M4GA/B
- MN4GA/B
- 4GA/B (master)
- 4GB With sensor
- 4GD/E
- M4GD/E
- MN4GD/E
- 4GA4/B4
- MN3E
- MN4E
- W4GA/B2
- W4GB4
- MN3S0
- MN4S0
- 4SA/B0
- 4KA/B**
- 4KA/B (master)
- 4F
- 4F (master)
- PV5G
- GMF
- PV5
- GMF
- PV5S-0
- 3Q
- MV3QR
- 3MA/B0
- 3PA/B
- P/M/B
- NP/NAP
- NVP
- 4G\*0EJ
- 4F\*0EX
- 4F\*0E
- HMV
- HSV
- 2QV
- 3QV
- SKH
- Silencer
- TotAirSys (Total Air)
- TotAirSys (Gamma)
- Ending

### 4KB410

● 2-position single: grommet lead wire

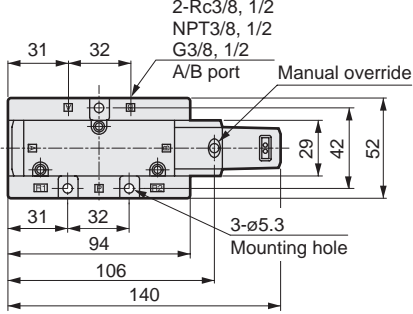

Lead wire length 300 mm  
(0.5 mm<sup>2</sup>, O.D. ø2)

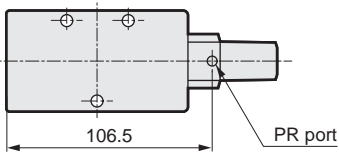
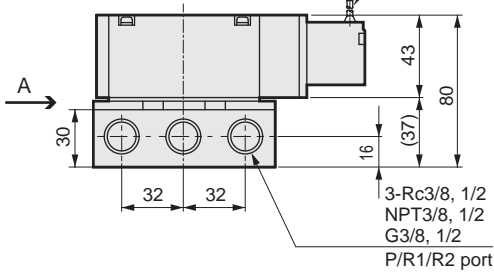

### 4KB420

● 2-position double: grommet lead wire

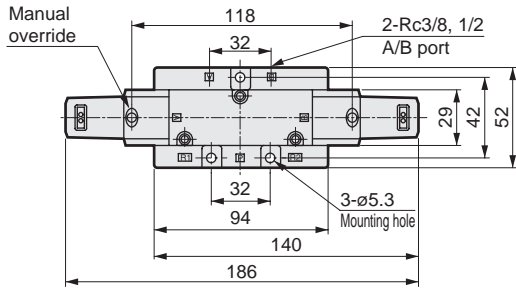

Lead wire length 300 mm  
(0.5 mm<sup>2</sup>, O.D. ø2)

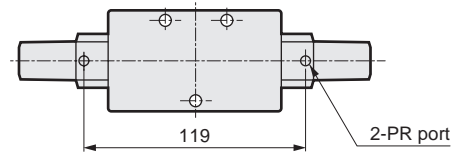
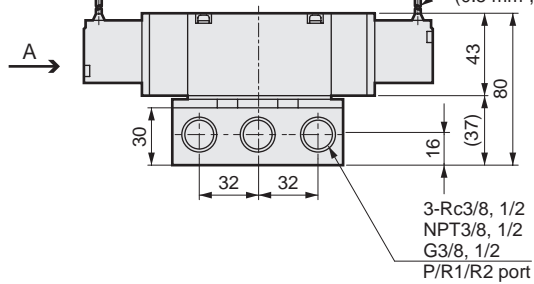

### 4KB440<sup>3</sup>/<sub>5</sub>

● 3-position: grommet lead wire

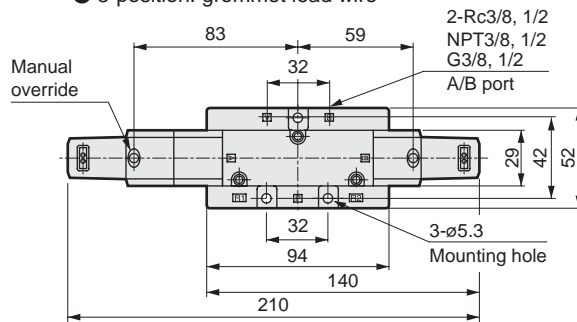

Lead wire length 300 mm  
(0.5 mm<sup>2</sup>, O.D. ø2)

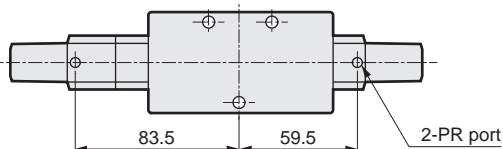
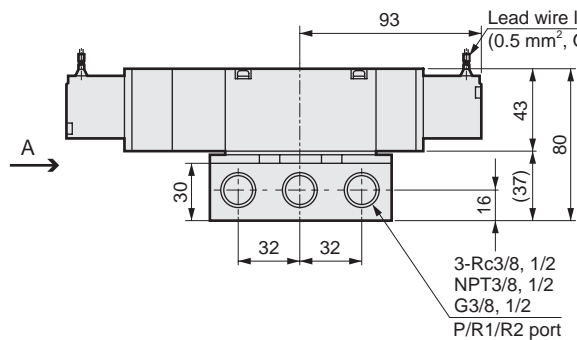

### Dimensions

● Terminal box: (B/L/LS)

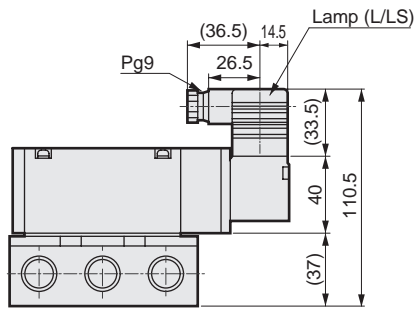

● C-connector: (C/C1/C0\*/C2/C2\*/C3)

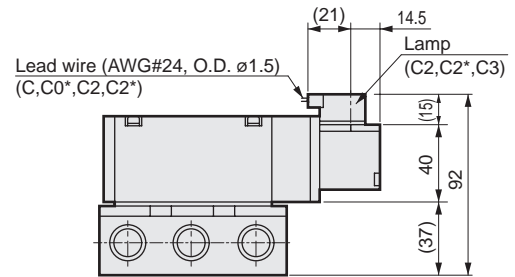

● D-connector: (D/D1/D0\*/D2/D2\*/D3)

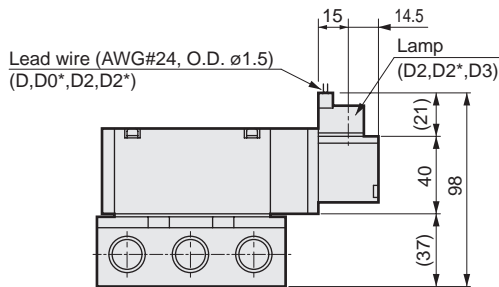

● External pilot: (K)

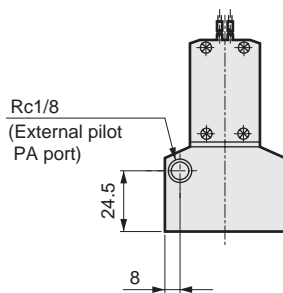

A arrow view

4GA/B
M4GA/B
MN4GA/B
4GA/B (master)
4GB With sensor
4GD/E
M4GD/E
MN4GD/E
4GA4/B4
MN3E
MN4E
W4GA/B2
W4GB4
MN3S0
MN4S0
4SA/B0
<b>4KA/B</b>
<b>4KA/B (master)</b>
4F
4F (master)
PV5G
GMF
PV5
GMF
PV5S-0
3Q
MV3QR
3MA/B0
3PA/B
P/M/B
NP/NAP
NVP
4G*0EJ
4F*0EX
4F*0E
HMV
HSV
2QV
3QV
SKH
Silencer
TotAirSys (Total Air)
TotAirSys (Gamma)
Ending