



COMPACT

TRASFORMATORI PER BRUCIATORI E ZANZARIERE

INFORMAZIONI E AVVERTENZE

- CAVO DI ALIMENTAZIONE CON SPINA
 - LUNGHEZZA CAVO STANDARD mm.450. ALTRE LUNGHEZZE A RICHIESTA
 - SE IL CAVO DI ALIMENTAZIONE DEVE ESSERE SOSTITUITO, LA SOSTITUZIONE DEVE ESSERE ESEGUITA CON UN NUOVO CAVO DI ALIMENTAZIONE FIDA
 - CAVI DI ALTA TENSIONE DISPONIBILI A RICHIESTA
 - IL TRASFORMATORE DI ACCENSIONE DEVE ESSERE USATO CON UNITA' DI CONTROLLO
 - SUL BRUCIATORE DEVE ESSERE MESSO IL SIMBOLO "ALTA TENSIONE": UN TRIANGOLO GIALLO CON UN LAMPO NERO
 - IL TRASFORMATORE DI ACCENSIONE E' PROTETTO DA POLVERE E UMIDITA', UTILIZZANDO CAVI AT FIDA CON GOMMINO
 - CARATTERISTICHE DI TENSIONE DIVERSE, A RICHIESTA (120V , 60 Hz E ALTRE)
-

AUSKÜNFTE UND WARNUNGEN

- STROMVERSORGUNGSKABEL MIT ANSCHLUßSTECKER
 - STANDARD KABELSLÄNGE mm.450. VERSCHIEDENEN LÄNGEN AUF WUNSCH
 - MUß DAS SPEISEKABEL ERNUERT WERDEN, MUß DIE ERNEUERUNG MIT EINEM NEUEN FIDA SPEISEKABEL GEMACHT WERDEN
 - HOCHSPANNUNGSKABEL ZUR VERFÜGUNG AIF WUNSCH
 - DER ZÜNDTRANSFORMATOR MUß MIT EINE KONTROLLEEINHEIT BENÜTZT WERDEN
 - AM BRENNER MUß DER SYMBOL "HOCHSPANNUNG" GESTELLT WERDEN: EIN GELBE DREIECK MIT EINEM SCHWARZEN BLITZ
 - GESCHÜTZT VOR STAUB UND FEUCHTIGKEIT, WENN MAN FIDA HOCHSPANNUNGSKABEL MIT DER SCHÜTZKAPPE BENUTZT WIRD.
 - VERSCHIEDENEN SPANNUNGSMERKMALEN AUF WUNSCH (120V, 60 Hz u.s.w.)
-

INFORMATIONS AND DIRECTIONS

- FEEDING CABLE WITH CONNECTOR
- STANDARD CABLE LENGTH mm.450. DIFFERENT LENGTHS ON DEMAND
- IF THE FEEDING CABLE HAS TO BE SUBSTITUTED, THE SUBSTITUTION MUST BE DONE WITH A NEW FIDA'S FEEDING CABLE
- HIGH TENSION CABLES AVAILABLE ON DEMAND
- THE IGNITION TRANSFORMER MUST BE USED WITH A CONTROL UNIT
- ON THE BURNER MUST BE PUT THE SYMBOL "HIGH VOLTAGE": A YELLOW TRIANGLE WITH A BLACK LIGHTNING
- THE IGNITION TRANSFORMER IS PROTECTED FROM DUST AND DAMP, USING FIDA'S CABLES WITH CAP.
- DIFFERENT TENSION CHARACTERISTICS ON DEMAND (120V, 60 Hz AND OTHERS)

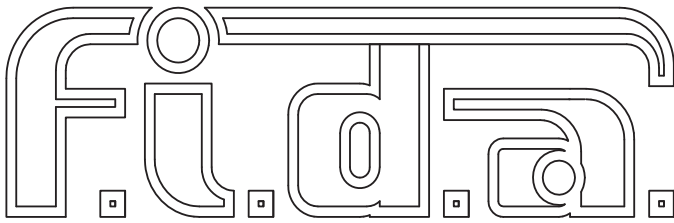

31021 MOGLIANO (TREVISO) - ITALY -
 VIA TIZIANO, 14 - TEL. 041 / 5970120
 FAX 041 / 5970116

BUILT IN IGNITION TRANSFORMERS
 EINBAU ZÜNDTRANSFORMATOREN
 TRANSFORMATEURS D'ALLUMAGE A INCORPORER
 TRASFORMATORI D'ACCENSIONE DA INCORPORARE

“COMPACT”®

DISEGNO DI PROPRIETA' DELLA FIDA CON DIVIETO DI DIVULGAZIONE
 E DI RIPRODUZIONE SALVO AUTORIZZAZIONE. LA FIDA SI RISERVA
 DI APPORTARE MODIFICHE SENZA PREAVVISO.

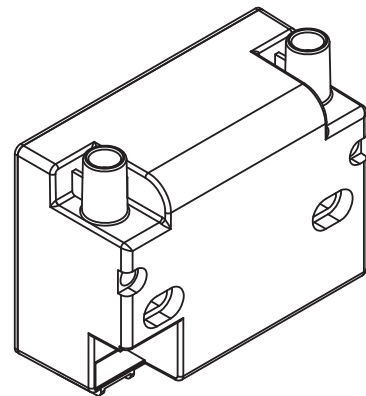
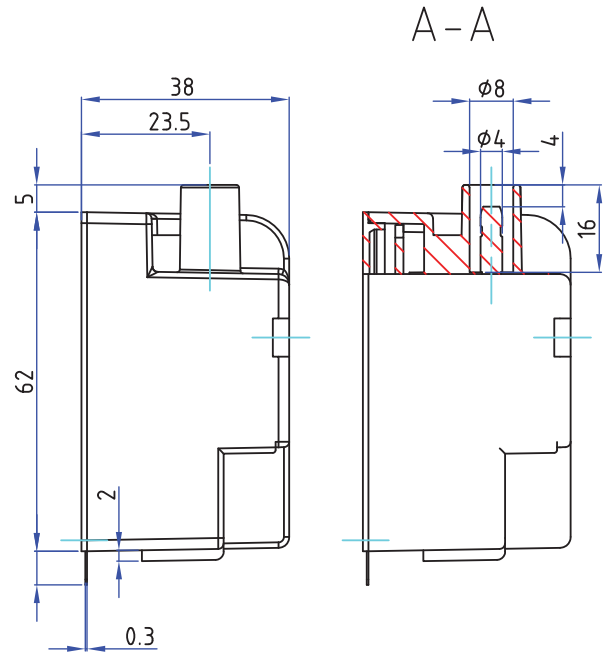
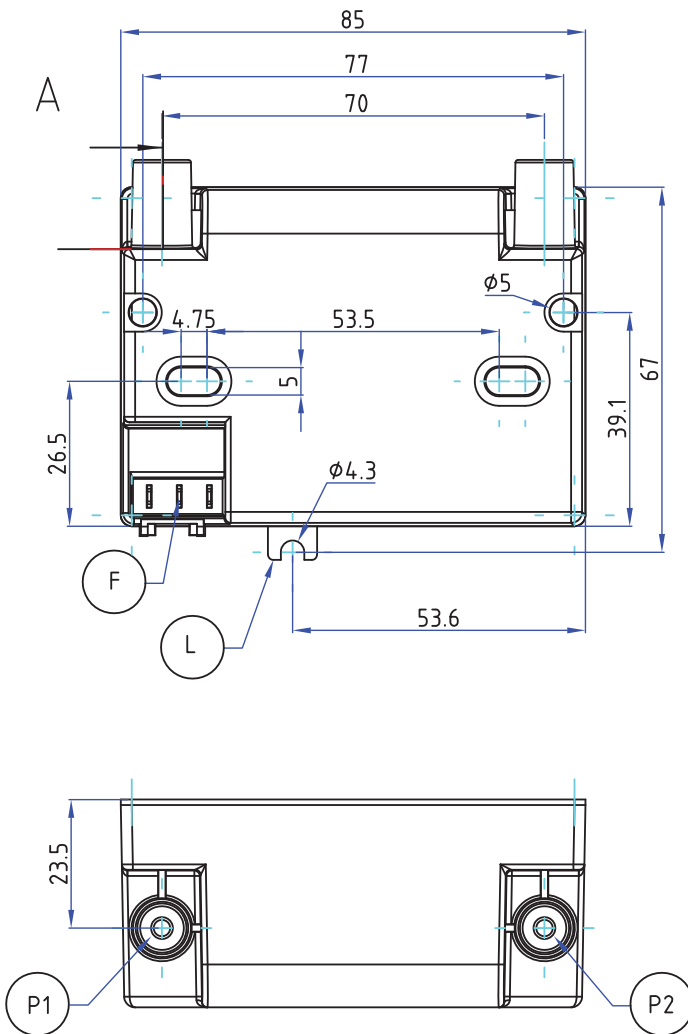

VARIATIONS

DESCRIPTION	F	P1	P2	L
ISOLATED	NO	YES	YES	NO
ISOLATED WITH GROUND CONNECTION	YES	YES	YES	NO
ISOLATED WITH GROUND CONNECTION BY RING	NO	YES	YES	YES
ONE POLE	YES	NO	YES	NO
ONE POLE WITH GROUND CONNECTION BY RING	YES	NO	YES	YES

ELECTRONIC TRANSFORMER
 REF.J



I - 31021 MOGLIANO VENETO (Treviso) - ITALY
Via Tiziano, 14 - S.P.Z.
Phone: +39 (0)41 5970120 - Fax: +39 (0)41 5970116

BUILT IN IGNITION TRANSFORMERS
EINBAU ZUENDTRANSFORMATOREN
TRASFORMATEUR D'ALLUMAGE A INCORPORER
TRASFORMATORI D'ACCENSIONE DA INCORPORARE

TYPE TYPE TYPE TIPO	INTERMITTENCE EINSCHALTDAUER INTERMITTENCE INTERMITTENZA	STANDARD POWER SUPPLY STROMVERSORGUNG ALIMENTATION STANDARD ALIMENTAZIONE STANDARD			HIGH VOLTAGE HOCHSPANNUNG HAUTE TENSION ALTA TENSIONE		MARKS ZEICHEN MARQUES MARCHI	
	A 35°	V	Hz	A	V	mA		
26/30 IS	100%	230/240	50/60	0,10	1x26000	30	CE	 EN 61558-2-3 RoHS
26/30 CM	100%	230/240	50/60	0,10	2x13000	30	CE	 EN 61558-2-3 RoHS
26/30 IT	100%	230/240	50/60	0,10	1x26000	30	CE	 EN 61558-2-3 RoHS
26/30 PM	100%	230/240	50/60	0,10	1x26000	30	CE	 EN 61558-2-3 RoHS
26/35 IS	50% su 3'	230/240	50/60	0,15	1x26000	35	CE	 EN 61558-2-3 RoHS
26/35 CM	50% su 3'	230/240	50/60	0,15	2x13000	35	CE	 EN 61558-2-3 RoHS
26/35 IT	50% su 3'	230/240	50/60	0,15	1x26000	35	CE	 EN 61558-2-3 RoHS
26/40 IT	33% su 3'	230/240	50/60	0,15	1x26000	40	CE	CONFORMED EN 61558-2-3 RoHS
26/48 IT	33% su 3'	230/240	50/60	0,35	1x26000	48	CE	CONFORMED EN 61558-2-3 RoHS
26/40 PM	50% su 3'	230/240	50/60	0,15	1x26000	40	CE	 EN 61558-2-3 RoHS
28/35 PM	33%	230/240	50/60	0,15	1x28000	35	CE	CONFORMED EN 61558-2-3 RoHS
26/30 IS	100%	200	50/60	0,22	1x26000	30	CE	CONFORMED EN 61558-2-3 RoHS
26/30 PM	100%	115/120	50/60	0,35	1x26000	30	CE	CONFORMED EN 61558-2-3 RoHS
26/30 IS	100%	115/120	50/60	0,35	1x26000	30	CE	CONFORMED EN 61558-2-3 RoHS

REF. Altre caratteristiche su richiesta - Other types on request.

F GRADO DI PROTEZIONE IP 44 UTILIZZANDO CAVI BT E AT FIDA SOVRASTAMPATI
PROTECTION DEGREE: IP 44 TOGETHER WITH FEEDING CABLE AND HIGH TENSION CABLE OVERPRINTED
BY FIDA

AQ

D

L CONNESSIONE A MASSA CON VITE GROUND CONNECTED THROUGH SCREW

CM USCITA AT DUE POLI - CENTRO A MASSA
TWO POLE OUTPUT HV - MIDPOINT GROUND CONNECTED

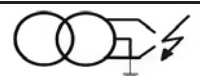

PM USCITA AT UN POLO - UN POLO A MASSA
ONE POLE OUTPUT HV - ONE POLE GROUND CONNECTED

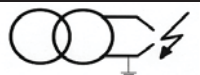

IS USCITA AT DUE POLI - ISOLATO
TWO POLE OUTPUT HV - ISOLATED



IT USCITA AT DUE POLI - PRIMARIO CON COLLEGAMENTO DI MASSA
TWO POLE OUTPUT HV - PRIMARY GROUND CONNECTED

