

March 2020

627 Series Pressure Reducing Regulators

WARNING

Failure to follow these instructions or to properly install and maintain this equipment could result in an explosion and/or fire causing property damage and personal injury or death.

Fisher™ regulators must be installed, operated and maintained in accordance with federal, state and local codes, rules and regulations, and Emerson Process Management Regulator Technologies, Inc. instructions.

If the regulator vents gas or a leak develops in the system, service to the unit may be required. Failure to correct trouble could result in a hazardous condition.

Call a gas service person to service the unit. Only a qualified person must install or service the regulator.

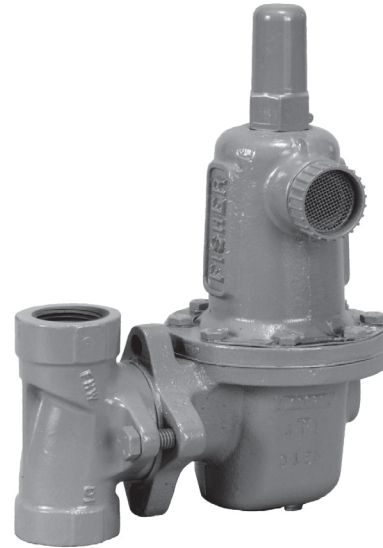

W4793

Figure 1. Typical 627 Direct-Operated Pressure Reducing Regulator

Introduction

Scope of the Manual

This manual provides instructions for the installation, adjustment, maintenance and parts ordering information for the 627 Series regulators. These regulators are usually shipped separate for line installation, although sometimes they are shipped installed on other equipment. Refer to the Instruction Manual of the other equipment for installation and operating instructions.

Description

The 627 Series direct-operated pressure reducing regulators (Figure 1) are for high and low pressure systems. These regulators can be used with natural gas, air or a variety of other gases. Performance characteristics vary according to construction.

WARNING

Personal injury, property damage, equipment damage or leakage due to escaping gas or bursting of pressure-containing parts may

result if this regulator is overpressured or is installed where service conditions could exceed the limits given in the Specifications section, Tables 1, 2, 3 and 4 or where conditions exceed any ratings of the adjacent piping or piping connections.

To avoid such injury or damage, provide pressure-relieving or pressure-limiting devices (as required by the appropriate code, regulation or standard) to prevent service conditions from exceeding those limits. The Type 627R, 627LR or 627MR regulator with internal relief will provide downstream overpressure protection within the limits given in the Specifications section, Tables 1, 2, 3 and 4. If these limits are exceeded, additional downstream overpressure protection must be provided by the user.

Additionally, physical damage to the regulator could cause personal injury or property damage due to escaping gas. To avoid such injury or damage, install the regulator in a safe location.

627 Series

Specifications

The Specifications section gives some general specifications for the 627 Series regulators. The nameplates give detailed information for a particular regulator as it comes from the factory.

Available Constructions

Type 627: Direct-operated pressure reducing regulator equipped with a pitot tube for greater regulated capacities (Figure 7).

Type 627R: Type 627 with internal relief and with an open throat (Figure 8).

Type 627LR: Type 627R with light rate relief spring (Figure 9).

Type 627M: Type 627 with a stem seal between the body outlet pressure and diaphragm case. Pressure is measured under the diaphragm through the 1/4 NPT downstream control line connection (Figure 10).

Type 627MR: Type 627M with internal relief (Figure 11).

Type 627H: Type 627 with a diaphragm limiter to deliver a higher outlet pressure (Figure 12).

Type 627HM: Type 627H with a stem seal between the body outlet pressure and diaphragm case. Pressure is measured under the diaphragm through the 1/4 NPT downstream control line connection (Figure 13).

Type 627OSX: Type 627 with Type OS2 slam shut device for overpressure protection. Available with Over and Under Pressure Trip points. (Figure 14)

Body Sizes and End Connection Styles

BODY SIZE		END CONNECTION STYLE	CONSTRUCTION AVAILABLE
NPS	DN		
3/4	---	NPT	All
1	25	NPT, CL150 RF, CL300 RF, CL600 RF and Long Body	
1-1/4	32	NPT	
2	50	NPT, CL150 RF, CL300 RF, CL600 RF and Long Body	

Maximum Inlet Pressure⁽¹⁾ (Body Rating)

Flanged Stainless Steel: 1440 psig / 99.3 bar

NPT Stainless Steel: 2000 psig / 138 bar

Flanged Steel: 1500 psig / 103 bar

NPT Steel: 2000 psig / 138 bar

NPT Steel (Type 627OSX):

1500 psig / 138 bar

Ductile Iron: 1000 psig / 69.0 bar

Maximum Valve Disk Inlet Pressure Rating⁽¹⁾

Nylon (PA) Disk: 2000 psig / 138 bar

Nitrile (NBR) Disk: 1000 psig / 69.0 bar

Fluorocarbon (FKM) Disk: 300 psig / 20.7 bar

Maximum Operating Inlet Pressure, Pressure Differential and Outlet Pressure Ranges⁽¹⁾

See Table 1 for pressures by orifice size and spring range

Maximum Spring and Diaphragm Casing Pressure⁽¹⁾

See Table 2

Maximum Body Outlet Pressure⁽¹⁾⁽²⁾

Types 627M, 627MR and 627HM only

NPT Steel: 2000 psig / 138 bar

Flanged Steel: 1500 psig / 103 bar

Ductile Iron: 1000 psig / 69.0 bar

Type 627OSX

NPT Steel: 1500 psig / 103 bar

Orifice Sizes

See Table 1

Internal Relief Performance

Type 627R: See Table 3

Type 627LR: See Table 4

Type 627MR: Limited by field-installed control line piping

Elastomer Temperature Capabilities⁽¹⁾⁽³⁾

MATERIAL	DISK/ DIAPHRAGM	TEMPERATURE	
		°F	°C
Nitrile (NBR)	Disk	-40 to 180	-40 to 82
	Diaphragm		
Fluorocarbon (FKM)	Disk	0 to 180	-18 to 82
	Diaphragm		
Nylon (PA)	Disk	-40 to 180	-40 to 82
Neoprene (CR) for Types 627H and 627HM only	Diaphragm	-40 to 180	-40 to 82
Nitrile (NBR) for Types 627OSX and 627MOSX only	Disk	-20 to 180	-29 to 82
	Diaphragm		
Neoprene (CR) for Types 627HOSX and 627HMOSX only	Diaphragm	-20 to 180	-29 to 82

Flow Coefficients

See Table 5

IEC Sizing Coefficients

See Table 6

Pressure Registration

Type 627, 627H, 627R, 627LR, 627OSX or 627HOSX:
Internal

Type 627M, 627HM, 627MR, 627MOSX or 627HMOSX:
External through 1/4 NPT control line connection in the diaphragm casing

1. The pressure/temperature limits in this Instruction Manual or any applicable standard limitation should not be exceeded.

2. Types 627, 627H, 627R, 627LR and 627OSX are limited by maximum diaphragm casing pressure.

3. Stainless steel body is rated to -40°F / -40°C. Steel and Ductile Iron bodies are rated to -20°F / -29°C.

Specifications (continued)

<p>De-Icer System See Figure 3 and Type 627M Regulator De-Icer System Application section</p> <p>Relief Indicator For Types 627R, 627LR and 627MR (see Figures 8, 9 and 11)</p> <p>Spring Case Vent Connection 3/4 NPT with removable screened vent assembly</p>	<p>Approximate Weights</p> <p>627 Series <i>Ductile Iron, Steel or Stainless steel Casings:</i> 10 lbs / 5 kg <i>Aluminum Casing:</i> 6.3 lbs / 3 kg</p> <p>Type 627OSX <i>NPS 1 / DN 25:</i> 40 lbs / 18 kg <i>NPS 2 / DN 50:</i> 42 lbs / 19 kg</p>
---	--

Principle of Operation

Refer to Figure 2. When downstream demand decreases, the pressure under the diaphragm increases. This pressure overcomes the regulator setting (which is set by a spring). Through the action of the pusher post assembly, lever and valve stem the valve disk moves closer to the orifice and reduces gas flow. If demand downstream increases, pressure under the diaphragm decreases. Spring force pushes the pusher post assembly downward and the valve disk moves away from the orifice.

Product Description

Types 627 and 627H Direct-Operated Pressure Reducing Regulators—The Types 627 and 627H regulators provide economical pressure reducing control for a variety of residential, commercial and industrial applications. The regulator pitot tube located in a high velocity stream provides dynamic boost that compensates for outlet pressure drop.

Type 627 Long Body—The Type 627 Long Body regulator can be used as a drop-in replacement for existing Type 630 installations without the need to modify piping.

Internal Relief for Type 627R, 627LR or 627MR Regulator—The Type 627R internal relief performance values were obtained **by removing the disk assembly** from the regulator. For the Type 627R, 627LR or 627MR regulator, the internal relief across the diaphragm provides overpressure protection in many applications. As outlet pressures build up above the start-to-discharge point, the diaphragm moves off the relief valve seat allowing the excess pressure to bleed out through the screened vent.

For extra protection, should failure conditions exist which would prevent normal operation of the regulator (for example, disk broken off or disk erosion), the pusher post contacts the lever retainer causing the relief valve assembly to open. Since the diaphragm continues to rise as downstream pressure builds, it opens the relief valve; thereby, opening the valve. This internal relief may be adequate for the application.

Downstream Control Line for Type 627M, 627HM, 627MR, 627MOSX or 627HMOSX Regulator—A Type 627M, 627HM, 627MR, 627MOSX or 627HMOSX regulator has a blocking throat stem seal with O-rings and a 1/4 NPT control line connection in the diaphragm case. A regulator with a downstream control line is used for monitoring applications or other applications where other equipment is installed between the regulator and the pressure control point. The stem seal separates the body outlet pressure from the diaphragm case.

Type 627OSX—The Type 627OSX regulator with integral slam-shut device can provide either overpressure (OPSO) or overpressure (OPSO) and underpressure (UPSO) protection by completely shutting off the flow of gas to the downstream system.

Installation

Regulator operation within ratings does not preclude the possibility of damage from debris in the lines or from external sources. A regulator should be inspected for damage periodically and after any overpressure condition. Key numbers referenced in this section are shown in Figures 7 through 13. Ensure that the operating temperature capabilities listed in Specifications section are not exceeded.

Note

If the regulator is shipped mounted on another unit, install that unit according to the appropriate Instruction Manual.

Perform steps 1 through 6 for all types of regulators:

1. Only personnel qualified through training and experience should install, operate or maintain this regulator.
2. For a regulator that is shipped separately, make sure that there is no damage to or foreign material in the regulator.
3. Ensure that all tubing and piping have been blown free of foreign debris.
4. The regulator may be installed in any position as long as the flow through the body is in the direction indicated by the arrow cast on the body.

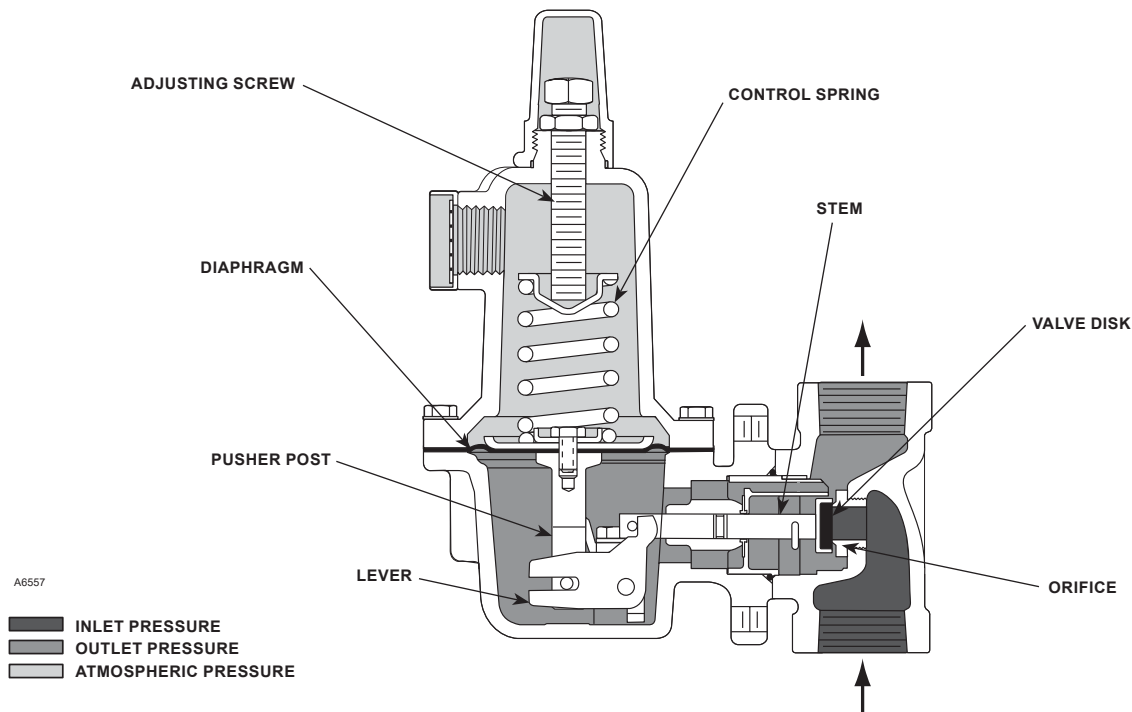

Figure 2. Type 627 Operational Schematic

Type 627OSX must be installed in a horizontal position and the mechanism box must be above or below the body. It is recommended to install vents upstream and downstream of the regulator between the shutoff valves. Pipe supports should be used for flanged Type 627OSX units due to weight.

See Type OS2 Instruction Manual (D102778X012) for additional information.

- If continuous operation is required during inspection or maintenance, install a three-valve bypass around the regulator.



WARNING

A regulator may vent some gas to the atmosphere. In hazardous or flammable gas service, vented gas may accumulate and cause personal injury, death or property damage due to fire or explosion. Vent a regulator in hazardous gas service to a remote, safe location away from air intakes or any hazardous area. The vent line or stack opening must be protected against condensation or clogging.

- Position the body (key 1) and/or diaphragm spring case (key 29) so it will not collect moisture or debris into the screened vent. If the regulator requires repositioning, refer to the Body Area Maintenance Procedures and/or the Diaphragm and Spring Case Area Maintenance

Procedures in the Maintenance section to reposition the screened vent for the application.

Perform steps 7 through 9 for Types 627M, 627HM, 627MR, 627MOSX and 627HMOSX regulators only:

- A Type 627M, 627HM, 627MR, 627MOSX or 627HMOSX regulator requires a downstream control line. Install the control line before putting the regulator into operation.
- Ensure that the downstream control line piping is at least 3/8 in. / 9.5 mm or larger outside diameter tubing and connected to a straight section of outlet piping 10 diameters downstream of the regulator.
- A hand valve should be installed in the control line. This hand valve can be used to throttle down and dampen outlet pulsations in control pressure which may cause instability or cycling of the regulator.

Remote Vent Line Installation

All 627 Series regulators have a vent assembly installed in the 3/4 NPT spring case vent opening. The vent assembly can be removed to install a remote vent line if necessary. Remote vent lines must have the largest practical diameter. It should be as short as possible with minimum number of bends or elbows.

Protect the remote vent opening against entrance of rain, snow or any other foreign material that may plug the vent or vent line and prevent proper operation of the regulator. Periodically check the vent opening to be sure it is not plugged with foreign debris.

Table 1. Maximum Inlet Pressures and Outlet Pressure Ranges

TYPE	OUTLET PRESSURE RANGE, SPRING PART NUMBER AND COLOR CODE	ORIFICE SIZE		MAXIMUM INLET PRESSURE ⁽¹⁾					
				Nylon (PA) Disk ⁽²⁾		Nitrile (NBR) Disk		Fluorocarbon (FKM) Disk	
		In.	mm	psig	bar	psig	bar	psig	bar
627, 627M and 627OSX ⁽⁴⁾	5 ⁽³⁾ to 20 psig / 0.34 to 1.4 bar 10B3076X012 Yellow	3/32	2.4	2000	138	1000	69.0	300	20.7
		1/8	3.2	1000	69.0	1000	69.0	300	20.7
		3/16	4.8	750	51.7	750	51.7	300	20.7
		1/4	6.4	500	34.5	500	34.5	300	20.7
		3/8	9.5	300	20.7	300	20.7	300	20.7
		1/2	13	250	17.2	250	17.2	250	17.2
	15 to 40 psig / 1.0 to 2.8 bar 10B3077X012 Green	3/32	2.4	2000	138	1000	69.0	300	20.7
		1/8	3.2	1500	103	1000	69.0	300	20.7
		3/16	4.8	1000	69.0	1000	69.0	300	20.7
		1/4	6.4	750	51.7	750	51.7	300	20.7
		3/8	9.5	500	34.5	500	34.5	300	20.7
		1/2	13	300	20.7	300	20.7	300	20.7
	35 to 80 psig / 2.4 to 5.5 bar 10B3078X012 Blue	3/32	2.4	2000	138	1000	69.0	300	20.7
		1/8	3.2	2000	138	1000	69.0	300	20.7
		3/16	4.8	1750	121	1000	69.0	300	20.7
		1/4	6.4	1500	103	1000	69.0	300	20.7
		3/8	9.5	1000	69.0	1000	69.0	300	20.7
		1/2	13	750	51.7	750	51.7	300	20.7
	70 to 150 psig / 4.8 to 10.3 bar 10B3079X012 Red	3/32	2.4	2000	138	1000	69.0	300	20.7
		1/8	3.2	2000	138	1000	69.0	300	20.7
3/16		4.8	2000	138	1000	69.0	300	20.7	
1/4		6.4	1750	121	1000	69.0	300	20.7	
3/8		9.5	1250	86.2	1000	69.0	300	20.7	
1/2		13	750	51.7	750	51.7	300	20.7	
627R and 627MR	5 ⁽²⁾ to 20 psig / 0.34 to 1.4 bar 10B3076X012 Yellow	3/32	2.4	2000	138	1000	69.0	300	20.7
		1/8	3.2	1000	69.0	1000	69.0	300	20.7
		3/16	4.8	750	51.7	750	51.7	300	20.7
		1/4	6.4	500	34.5	500	34.5	300	20.7
		3/8	9.5	300	20.7	300	20.7	300	20.7
		1/2	13	200	13.8	200	13.8	200	13.8
	15 to 40 psig / 1.0 to 2.8 bar 10B3077X012 Green	3/32	2.4	2000	138	1000	69.0	300	20.7
		1/8	3.2	1500	103	1000	69.0	300	20.7
		3/16	4.8	1000	69.0	1000	69.0	300	20.7
		1/4	6.4	750	51.7	750	51.7	300	20.7
		3/8	9.5	300	20.7	300	20.7	300	20.7
		1/2	13	200	13.8	200	13.8	200	13.8
	35 to 80 psig / 2.4 to 5.5 bar 10B3078X012 Blue	3/32	2.4	2000	138	1000	69.0	300	20.7
		1/8	3.2	1750	121	1000	69.0	300	20.7
		3/16	4.8	1000	69.0	1000	69.0	300	20.7
		1/4	6.4	750	51.7	750	51.7	300	20.7
3/8		9.5	300	20.7	300	20.7	300	20.7	
1/2		13	200	13.8	200	13.8	200	13.8	
70 to 150 psig / 4.8 to 10.3 bar 10B3079X012 Red	3/32	2.4	2000	138	1000	69.0	300	20.7	
	1/8	3.2	1000	69.0	1000	69.0	300	20.7	
	3/16	4.8	500	34.5	500	34.5	300	20.7	
	1/4	6.4	300	20.7	300	20.7	300	20.7	
	3/8	9.5	200	13.8	200	13.8	200	13.8	
	1/2	13	200	13.8	200	13.8	200	13.8	
627LR	15 to 40 psig / 1.0 to 2.8 bar 10B3077X012 Green	3/32	2.4			1000	69.0	300	20.7
		1/8	3.2			1000	69.0	300	20.7
		3/16	4.8			750	51.7	300	20.7
		1/4	6.4			500	34.5	300	20.7
627H, 627HM and 627HOSX ⁽⁴⁾	140 to 250 psig / 9.7 to 17.2 bar 10B3078X012 Blue	3/32	2.4	2000	138	1000	69.0		
		1/8	3.2	2000	138	1000	69.0		
		3/16	4.8	1750	121	1000	69.0		
		1/4	6.4	1500	103	1000	69.0		
		3/8	9.5	1000	69.0	750	51.7		
		1/2	13	750	51.7	500	34.5		
	240 to 500 psig / 16.5 to 34.5 bar 10B3079X012 Red	3/32	2.4	2000	138	1000	69.0		
		1/8	3.2	2000	138	1000	69.0		
		3/16	4.8	1750	121	1000	69.0		
		1/4	6.4	1500	103	1000	69.0		
		3/8	9.5	1000	69.0	1000	69.0		
		1/2	13	750	51.7	750	51.7		

■ - Shaded areas indicate that Fluorocarbon (FKM) and Nylon (PA) disk material are not available.

1. For inlet pressure in excess of 1000 psig / 69.0 bar, refer to the maximum body and disk pressure ratings in the Specifications section.

2. Maximum inlet pressure for Type 627OSX is limited to 1500 psi / 103 bar.

3. For pressure settings under 10 psig / 0.69 bar, inlet pressure should be limited to approximately 100 psig / 6.9 bar so the setpoint adjustment can be obtained.

4. The unbalance forces change from the wide-open monitor mode to an active regulator mode such that the Type 627M or 627HM should have a 3/8 in. / 9.5 mm or larger orifice.

Table 2. Maximum Spring and Diaphragm Casing Pressure⁽¹⁾

MAXIMUM PRESSURE DESCRIPTION	DIAPHRAGM CASING MATERIAL	TYPES 627 AND 627OSX		TYPES 627R AND 627LR		TYPES 627M AND 627MOSX		TYPE 627MR		TYPES 627H, 627HM, 627HOSX AND 627HMOSX	
		psig	bar	psig	bar	psig	bar	psig	bar	psig	bar
Maximum pressure to spring and diaphragm casings to prevent leak to atmosphere other than relief action (internal parts damage may occur)	Die cast aluminum	250	17.2	250	17.2	Not Available		Not Available		Not Available	
	Ductile iron					250	17.2	Not Available		Not Available	
	Steel or Stainless steel					250	17.2	250	17.2	250	17.2
Maximum pressure to spring and diaphragm casings to prevent burst of casings during abnormal operation (leak to atmosphere and internal parts damage may occur)	Die cast aluminum	375	25.9	375	25.9	Not Available		Not Available		Not Available	
	Ductile iron	465	32.1	465	32.1	465	32.1	465	32.1	Not Available	
	Steel or Stainless steel	1500	103	1500	103	1500	103	1500	103	1500	103
Maximum diaphragm casing overpressure (above setpoint) to prevent damage to internal parts	All materials	60	4.1	120	8.3	60	4.1	120	8.3	120	8.3

1. If the spring case is pressurized, a metal adjusting screw cap is required. Contact your local Sales Office for details.

Type 627M or 627HM Regulator De-Icer System Application

For the Type 627M or 627HM regulator de-icer system, refer to the application shown in Figure 3. With a large pressure drop across the working regulator, ice can form within this regulator. The formation of ice decreases the size of the orifice, so the regulator is unable to supply enough flow to satisfy the downstream demand. When the downstream pressure falls below the outlet pressure setting of the Type 627M or 627HM regulator, the disk assembly of the Type 627M or 627HM regulator moves off its orifice, permitting alcohol to flow into the main gas line. The alcohol carried to the main regulator by the flowstream prevents additional ice from forming on the orifice. When normal flow resumes and as pressure in the downstream system is restored, the Type 627M or 627HM regulator shuts off.

Overpressure Protection

627 Series regulators have outlet pressure ratings that are lower than their inlet pressure ratings. A pressure-relieving or pressure-limiting device must be provided by the user for the Types 627, 627H, 627M and 627HM regulators if the inlet pressure can exceed the outlet pressure rating, since these regulators do not have internal relief.

Types 627R and 627LR regulators provide internal relief which limits the total outlet pressure buildup over setpoint. Use Tables 3 and 4 to determine the total outlet pressure. This internal relief may be adequate for the application, if not, provide additional pressure relief or a pressure-limiting device downstream.

Types 627OSX utilizes integral slam-shut device to provide overpressure and underpressure protection by completely shutting off the flow of gas to the downstream system.

Pressure is registered on one side of the diaphragm, piston or bellows and is opposed by the setpoint control spring of the manometric sensing device. The Type OS2 slam-shut valve tripping pressure is determined by the setting of the control spring.

Overpressure—When the downstream pressure increases above the setpoint, the pressure on top of the diaphragm overcomes the spring setting and moves the manometric device stem.

Underpressure—When the downstream pressure decreases below the setpoint, the control spring pressure below the diaphragm overcomes the downstream pressure and pushes the diaphragm which moves the manometric device stem. See Type OS2 Instruction Manual (D102778X012) for additional information.

Startup and Adjustment

Startup



WARNING

To avoid personal injury or property damage due to explosion or damage to regulator or downstream components during startup, release downstream pressure to prevent an overpressure condition on the diaphragm of the regulator.

In order to avoid an overpressure condition and possible equipment damage, pressure gauges should always be used to monitor pressures during startup.

1. Slowly open the upstream shut-off valve.
2. Slowly open the downstream shut-off valve.
3. Check all connections for leaks.
4. Make final control spring adjustments according to the adjustment procedures.

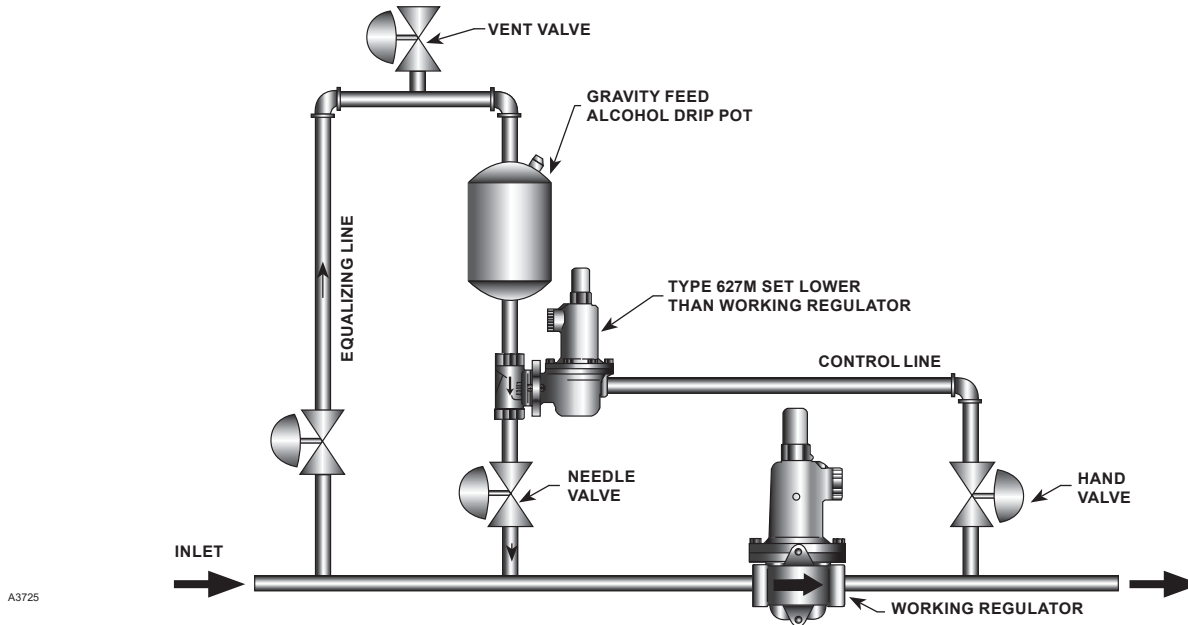

Figure 3. De-Icer System Operational Schematic

Adjustment

The range of allowable pressure settings is marked on the nameplate. If a pressure setting beyond this range is necessary, substitute the appropriate regulator control spring. Change the nameplate to indicate the new pressure range.

Before increasing the setting, refer to Table 1, 2, 3 or 4. Review the pressure limits for the control spring range being used and be certain that the new pressure setting will not result in an overpressure condition.

Note

Always use a pressure gauge to monitor pressure when making adjustments.

Refer to Figures 7 through 13 for key number locations.

1. Remove the adjusting screw cap (key 36).
2. Loosen the locknut (key 34).
3. Increase the outlet pressure setting by turning the adjusting screw (key 35) clockwise. Decrease the outlet pressure setting by turning the adjusting screw counterclockwise.
4. When the desired pressure is obtained, hold the adjusting screw (key 35) in place and tighten the locknut (key 34).

Refer to Type OS2 Instruction Manual (D102778X012) for instructions on adjusting the slam-shut.

Shutdown

WARNING

To avoid personal injury or property damage due to explosion or damage to regulator or downstream components during shutdown, release downstream pressure to prevent an overpressure condition on the diaphragm of the regulator.

1. Close the nearest upstream shut-off valve.
2. Close the nearest downstream shut-off valve.
3. Open the vent valve between the regulator and the downstream shut-off valve nearest to it.
4. For a Type 627, 627H, 627R or 627LR regulator, the regulator will open to release pressure between the upstream shut-off valve and the regulator.
5. A Type 627M, 627HM or 627MR regulator requires venting the control line and downstream pressure from the regulator before maintenance. The pressure between these shut-off valves is released through the open regulator because the disk assembly remains open in response to the decrease in control line pressure.
6. Type 627OSX with underpressure protection may trip and trap gas upstream of the regulator. It is recommended to also open an upstream vent to allow gas to escape.

Table 3. Type 627R Internal Relief Performance⁽¹⁾

OUTLET PRESSURE RANGE, SPRING PART NUMBER AND COLOR CODE	OUTLET PRESSURE SETTING		MAXIMUM ALLOWABLE DOWNSTREAM SYSTEM PRESSURE		MAXIMUM INLET PRESSURE TO KEEP MAXIMUM ALLOWABLE DOWNSTREAM SYSTEM PRESSURE FROM BEING EXCEEDED ⁽²⁾														
					Orifice Size, In. / mm														
					3/32 / 2.4		1/8 / 3.2		3/16 / 4.8		1/4 / 6.4		3/8 / 9.5		1/2 / 13				
					psig	bar	psig	bar	psig	bar	psig	bar	psig	bar	psig	bar			
5 ⁽³⁾ to 20 psig / 0.34 to 1.4 bar 10B3076X012 Yellow	10	0.69	60	4.1	1250	86.2	740	51.0	320	22.1	190	13.1	95	6.6	75	130	5.2		
			100	6.9	2000	138	1500	103	620	42.7	390	26.9	180	12.4				160	9.0
			125	8.6	2000	138	1900	131	830	57.2	480	33.1	220	15.2				220	11.0
			175	12.1	2000	138	2000	138	1100	75.8	670	46.2	320	22.1				260	15.2
			200	13.8	2000	138	2000	138	1300	89.6	770	53.1	360	24.8				320	17.9
	250	17.2	2000	138	2000	138	1600	110	960	66.2	450	31.0	320	22.1					
	15	1.0	60	4.1	1000	69.0	620	42.7	260	17.9	170	11.7	90	6.2	70	130	4.8		
			100	6.9	2000	138	1400	96.5	610	42.1	370	25.5	170	11.7				160	9.0
			125	8.6	2000	138	1900	131	810	55.8	480	33.1	220	15.2				220	11.0
			175	12.1	2000	138	2000	138	1100	75.8	670	46.2	320	22.1				260	15.2
			200	13.8	2000	138	2000	138	1300	89.6	770	53.1	360	24.8				320	17.9
	250	17.2	2000	138	2000	138	1600	110	960	66.2	450	31.0	320	22.1					
20	1.4	60	4.1	850	58.6	490	33.8	210	14.5	130	9.0	80	5.5	65	120	8.3			
		100	6.9	2000	138	1300	89.6	600	41.4	360	24.8	170	11.7				120	8.3	
		125	8.6	2000	138	1800	124	800	55.2	480	33.1	220	15.2				160	11.0	
		175	12.1	2000	138	2000	138	1100	75.8	670	46.2	320	22.1				220	15.2	
		200	13.8	2000	138	2000	138	1300	89.6	770	53.1	360	24.8				260	17.9	
250	17.2	2000	138	2000	138	1600	110	960	66.2	450	31.0	320	22.1						
15 to 40 psig / 1.0 to 2.8 bar 10B3077X012 Green	15	1.0	60	4.1	1000	69.0	380	26.2	210	14.5	130	9.0	80	5.5	65	120	8.3		
			100	6.9	2000	138	1300	89.6	590	40.7	350	24.1	170	11.7				120	8.3
			125	8.6	2000	138	1800	124	800	55.2	470	32.4	220	15.2				160	11.0
			175	12.1	2000	138	2000	138	1100	75.8	640	44.1	320	22.1				220	15.2
			200	13.8	2000	138	2000	138	1300	89.6	780	53.8	370	25.5				260	17.9
	250	17.2	2000	138	2000	138	1600	66.2	960	66.2	450	31.0	320	22.1					
	20	1.4	60	4.1	630	43.4	200	13.8	150	10.3	100	6.9	70	4.8	65	120	8.3		
			100	6.9	2000	138	1200	82.7	550	37.9	330	22.8	160	11.0				120	8.3
			125	8.6	2000	138	1700	117	760	52.4	450	31.1	210	14.5				160	11.0
			175	12.1	2000	138	2000	138	1100	75.8	630	43.4	320	22.1				220	15.2
			200	13.8	2000	138	2000	138	1300	89.6	770	53.1	360	24.8				260	17.9
	250	17.2	2000	138	2000	138	1600	66.2	960	66.2	460	31.7	320	22.1					
30	2.1	100	6.9	2000	138	950	65.5	450	31.1	260	17.9	140	9.7	110	150	10.3			
		125	8.6	2000	138	1500	103	670	46.2	400	27.6	190	13.1				150	10.3	
		175	12.1	2000	138	2000	138	1000	69.0	610	42.1	300	20.7				220	15.2	
		200	13.8	2000	138	2000	138	1200	82.7	760	52.4	360	24.8				260	17.9	
		250	17.2	2000	138	2000	138	1600	110	970	66.9	460	31.7				320	22.1	
40	2.8	100	6.9	1500	103	700	48.3	330	22.8	200	13.8	120	8.3	108	140	9.7			
		125	8.6	2000	138	1300	89.6	560	38.6	340	23.4	180	12.4				140	9.7	
		175	12.1	2000	138	1800	124	1000	69.0	550	37.9	290	20.0				220	15.2	
		200	13.8	2000	138	2000	138	1200	82.7	730	50.3	350	24.1				250	17.2	
		250	17.2	2000	138	2000	138	1600	110	970	66.9	460	31.7				320	22.1	

Shaded areas indicate maximum inlet pressures allowed during system malfunction only. Table 1 gives the maximum inlet pressure for normal regulator operation.

1. The internal relief performance values are obtained by removing the disk assembly.

2. For inlet pressures in excess of 1000 psig / 69.0 bar, refer to the maximum body and disk pressure ratings in the Specifications section.

3. For pressure settings under 10 psig / 0.69 bar, inlet pressure should be limited to approximately 100 psig / 6.9 bar so the setpoint adjustment can be obtained.

- continued -

Maintenance

Unless otherwise specified, the following maintenance procedures apply to all types of regulators. For a summary of maximum torque values required for all types of regulators, refer to Table 7.

Due to normal wear, damage from external sources or debris in the air or gas line, regulator parts such as the disk assembly orifice and diaphragm must be inspected periodically and replaced as necessary to ensure correct performance. The frequency of inspection and replacement depends upon the severity of conditions and the requirements of state and federal laws. Normal wear of the orifice and disk assembly is accelerated with high pressure drops and with large amounts of impurities in the flowstream. Instructions are given below for replacing the disk assembly orifice, diaphragm and O-rings. These procedures may also be used for disassembly required for inspection and replacement of other parts.

Note

Special tool required for Type 627OSX Orifice Maintenance. 14 mm Hex with a 4 in. / 102 mm extension required to reach orifice.

Refer to Type OS2 Instruction Manual (D102778X012) for instructions on maintaining the slam-shut.

Problem Indication for Types 627R, 627LR and 627MR Regulators



WARNING

Isolate the regulator from all pressure to avoid personal injury and equipment damage due to explosion or sudden release of process pressure. Cautiously release pressure from the regulator before attempting disassembly.

Table 3. Type 627R Internal Relief Performance⁽¹⁾ (continued)

OUTLET PRESSURE RANGE, SPRING PART NUMBER AND COLOR CODE	OUTLET PRESSURE SETTING		MAXIMUM ALLOWABLE DOWNSTREAM SYSTEM PRESSURE		MAXIMUM INLET PRESSURE TO KEEP MAXIMUM ALLOWABLE DOWNSTREAM SYSTEM PRESSURE FROM BEING EXCEEDED ⁽²⁾⁽³⁾											
					Orifice Size, In. / mm											
					3/32 / 2.4		1/8 / 3.2		3/16 / 4.8		1/4 / 6.4		3/8 / 9.5		1/2 / 13	
	psig	bar	psig	bar	psig	bar	psig	bar	psig	bar	psig	bar	psig	bar	psig	bar
35 to 80 psig / 2.4 to 5.5 bar 10B3078X012 Blue	40	2.8	125	8.6	2000	138	1100	75.8	500	34.5	300	20.7	170	11.7	140	9.7
			150	10.3	2000	138	1600	110	750	51.7	440	30.3	230	15.9	180	12.4
			175	12.1	2000	138	2000	138	980	67.6	580	40.0	290	20.0	220	15.2
			200	13.8	2000	138	2000	138	1200	82.7	720	49.6	340	23.4	250	17.2
	50	3.4	125	8.6	1400	96.5	820	56.5	400	27.6	230	15.9	150	10.3	140	9.7
			150	10.3	2000	138	1400	96.5	650	44.8	370	25.5	210	14.5	170	11.7
			175	12.1	2000	138	1900	131	700	48.3	530	36.5	270	18.6	210	14.5
			200	13.8	2000	138	2000	138	1100	75.8	670	46.2	330	22.8	240	16.5
	60	4.1	125	8.6	900	62.1	450	31.0	270	18.6	190	13.1	140	9.7	130	9.0
			150	10.3	1700	117	1100	75.8	540	37.2	300	20.7	190	13.1	160	11.0
			175	12.1	2000	138	1700	117	780	53.8	470	32.4	250	17.2	200	13.8
			200	13.8	2000	138	2000	138	1000	69.0	610	42.1	310	21.4	230	15.9
	70	4.8	150	10.3	1200	82.7	850	58.6	430	29.6	250	17.2	170	11.7	160	11.0
			175	12.1	2000	138	1400	96.5	670	46.2	400	27.6	230	15.9	190	13.1
			200	13.8	2000	138	2000	138	920	63.4	550	37.9	280	19.3	230	15.9
			250	17.2	2000	138	2000	138	1300	89.6	830	57.2	400	27.6	310	21.4
	80	5.5	150	10.3	800	55.2	500	34.5	300	20.7	200	13.8	160	11.0	150	10.3
			175	12.1	1500	103	1200	82.7	550	37.9	330	22.8	210	14.5	190	13.1
			200	13.8	2000	138	1700	117	800	55.2	480	33.1	270	18.6	220	15.2
			250	17.2	2000	138	2000	138	1200	82.7	770	53.1	390	26.9	300	20.7
70 to 150 psig / 4.8 to 10.3 bar 10B3079X012 Red	70	4.8	175	12.1	1900	131	600	41.4	400	27.6	260	17.9	200	13.8	175	12.1
			200	13.8	2000	138	1200	82.7	630	43.4	380	26.2	250	17.2	210	14.5
			250	17.2	2000	138	2000	138	1100	75.8	680	46.9	360	24.8	290	20.0
	80	5.5	175	12.1	1400	96.5	250	17.2	240	16.5	200	13.8	190	13.1	175	12.1
			200	13.8	2000	138	960	66.2	520	35.9	330	22.8	240	16.5	210	14.5
100	6.9	200	13.8	1500	103	250	17.2	240	16.5	230	15.9	210	14.5	210	14.5	
		250	17.2	2000	138	1600	110	770	53.1	520	35.9	320	22.1	270	18.6	
125	8.6	250	17.2	2000	138	1000	69.0	500	34.5	390	26.9	290	20.0	260	17.9	
150	10.3	250	17.2	1200	82.7	260	17.9	260	17.9	260	17.9	260	17.9	260	17.9	

- Shaded areas indicate maximum inlet pressures allowed during system malfunction only. Table 1 gives the maximum inlet pressure for normal regulator operation.
 1. The internal relief performance values are obtained by removing the disk assembly.
 2. For inlet pressures in excess of 1000 psig / 69.0 bar, refer to the maximum body and disk pressure ratings in the Specifications section.
 3. For pressure settings under 10 psig / 0.69 bar, inlet pressure should be limited to approximately 100 psig / 6.9 bar so the setpoint adjustment can be obtained.

Table 4. Type 627LR Internal Relief Performance⁽¹⁾

OUTLET PRESSURE RANGE, SPRING PART NUMBER AND COLOR CODE	OUTLET PRESSURE SETTING		MAXIMUM ALLOWABLE DOWNSTREAM SYSTEM PRESSURE		MAXIMUM INLET PRESSURE TO KEEP MAXIMUM ALLOWABLE DOWNSTREAM SYSTEM PRESSURE FROM BEING EXCEEDED ⁽²⁾							
					Orifice Size, In. / mm							
					3/32 / 2.4		1/8 / 3.2		3/16 / 4.8		1/4 / 6.4	
	psig	bar	psig	bar	psig	bar	psig	bar	psig	bar	psig	bar
15 to 40 psig / 1.03 to 2.8 bar 10B3077X012 Green	30	2.1	55	3.8	500	34.5	270	18.6	110	7.6	80	5.5
			60	4.1	850	58.6	480	33.1	200	13.8	120	8.3
			66	4.5	1000	69.0	660	45.5	290	20.0	175	12.1
	40	2.8	66	4.5	380	26.2	190	13.1	85	5.9	80	5.5
			70	4.8	700	48.3	370	25.5	150	10.3	115	7.9
			75	5.2	1000	69.0	560	38.6	240	16.5	160	11.0

1. The internal relief performance values are obtained by removing the disk assembly.
 2. For inlet pressures in excess of 1000 psig / 69.0 bar, refer to the maximum body and disk pressure ratings in the Specifications section.

627 Series

Table 5. Flow Coefficients

ORIFICE		3/4 NPT			NPS 1 / DN 25 BODY				NPS 1-1/4 / DN 32 BODY			NPS 2 / DN 50 BODY			
In.	mm	Wide-Open C ₉ for External Relief Sizing	Wide-Open C _v for External Relief Sizing	C ₁	Wide-Open C ₉ for External Relief Sizing	Wide-Open C ₉ for External Relief Sizing for Type 627OSX only	Wide-Open C _v for External Relief Sizing	C ₁	Wide-Open C ₉ for External Relief Sizing	Wide-Open C _v for External Relief Sizing	C ₁	Wide-Open C ₉ for External Relief Sizing	Wide-Open C ₉ for External Relief Sizing for Type 627OSX only	Wide-Open C _v for External Relief Sizing	C ₁
3/32	2.4	6.9	0.24	29.2	6.9	6.8	0.24	28.5	7.0	0.23	30.7	6.9	6.7	0.23	29.7
1/8	3.2	12.5	0.43	29.1	12.5	11.4	0.43	29.4	12.1	0.43	28.0	12.5	11.2	0.42	29.5
3/16	4.8	29	1.01	28.6	29	27	0.93	31.2	26	0.92	28.7	29	28.4	1.02	28.5
1/4	6.4	50	1.63	30.6	50	47.6	1.71	29.3	43	1.45	30.0	52	47.5	1.66	31.3
3/8	9.5	108	2.99	36.1	108	107	3.42	31.6	96	3.33	28.9	115	107.4	3.39	33.9
1/2	13	190	4.87	39.0	190	166.4	5.29	35.9	168	5.18	32.4	200	169.1	5.01	39.9

Table 6. IEC Sizing Coefficients

ORIFICE SIZE		X _T			F ₀	F _L
In.	mm	3/4 NPT Body	NPS 1 / DN 25 Body	NPS 2 / DN 50 Body		
3/32	2.4	0.539	0.514	0.558	0.50	0.85
1/8	3.2	0.536	0.547	0.539		0.79
3/16	4.8	0.517	0.616	0.514		0.85
1/4	6.4	0.592	0.543	0.620		0.87
3/8	9.5	0.824	0.632	0.727		0.89
1/2	13	0.962	0.815	1.01		0.86

Table 7. Maximum Torque Values

KEY NUMBER ⁽¹⁾	DESCRIPTION	MAXIMUM TORQUE	
		FOOT-POUNDS	N•m
2	Orifice	25	34
3	Cap screw (with aluminum diaphragm casing)	16	22
	Cap screw (with ductile iron or steel/stainless steel diaphragm casing)	25	34
18	Lever cap screw	7	9.5
22	Diaphragm connector nut	17	23
26	Guide retainer (for Types 627R, 627LR and 627MR only)	3	4.1
37	Spring case cap screw (with aluminum or ductile iron diaphragm casing)	7	9.5
	Spring case cap screw (with steel/stainless steel diaphragm casing)	35	47
46	Diaphragm cap screw (with Type 627 or 627M)	7	9.5
	Diaphragm cap screw (with Type 627H or 627HM)	14	19
75	Slam-Shut Valve orifice	25	34

1. Refer to Figures 7 through 13 for key number locations.

The vent assembly is equipped with a relief indicator (key 49, Figure 4). The cap for the relief indicator snaps over the vent assembly opening. If the relief valve opens wide, exhaust gas pops the cap off the screen vent assembly opening indicating a problem with the regulator. If the cap pops off, refer to the shutdown and to the Body Area Maintenance Procedures to inspect the disk assembly and orifice.

If the disk assembly and orifice are not damaged, refer to the Diaphragm and Spring Case Area Maintenance Procedures in this section.

The disk assembly and orifice can be inspected, removed and replaced without removing the regulator body from the line connections. Refer to the Body Area Maintenance Procedures.

Body Area Maintenance Procedures

These procedures are for gaining access to the disk assembly orifice, diaphragm casing O-ring and stem assembly. All pressure must be released from the diaphragm casing before performing these steps.

While using the following procedures, refer to Figures 7 through 13 for key number locations.

Replacing the Disk Assembly or Orifice

- To inspect and replace the disk assembly (key 9) or orifice (key 2), remove the cap screws (key 3, Figure 5) and separate the diaphragm casing (key 5) from the body (key 1).
- Inspect and, if necessary, remove the orifice (key 2). If removed, coat the threads of the replacement orifice with lubricant and torque to 25 ft-lbs / 34 N•m.
- Inspect the disk assembly (key 9) and, if necessary, remove the hair pin clip (key 13) that holds the disk assembly (key 9) in place. If replacing the disk assembly is the only maintenance required, skip to step 16.

Replacing the Stem Assembly

If it is necessary to perform maintenance on the stem assembly, continue with steps 4 through 8 and 15 through 19 for Types 627, 627H, 627R and 627LR regulators or steps 9 through 19 for Types 627M, 627HM and 627MR regulators.

Perform steps 4 through 8 for Types 627, 627H, 627R, 627LR, 627OSX and 627HOSX Regulators only:

4. Use steps 5 through 8 to remove and replace the stem assembly.
5. Remove the boost body (key 6), stabilizer (key 7) and stem guide (key 8) from the diaphragm casing (key 5). Unhook and remove the stem (key 10) from the diaphragm casing (key 5).
6. Remove and inspect the diaphragm casing O-ring (key 4, Figure 7, 8, 9 or 12) and replace it if necessary.
7. Apply lubricant to a replacement diaphragm casing O-ring (key 4, Figure 7, 8, 9 or 12) and install it on the boost body (key 6). Skip to step 14.
8. For the Type 627 or 627H regulators, be sure to insert the pitot tube (tab) into the outlet side of the body (see Figure 7 or 12). Skip to step 14.

Perform steps 9 through 19 for Types 627M, 627HM, 627MR, 627MOSX and 627HMOSX Regulators only:

9. Use steps 10 through 14 to remove and replace the stem assembly.
10. To remove the blocked throat (key 43), insert a screw driver blade into the groove provided in the throat and pry it out of the diaphragm casing (key 5). Inspect and replace parts as necessary.
11. Inspect and, if necessary, replace the blocked throat O-rings (key 44, Figure 5) and back-up rings (key 45, Figure 5).
12. Apply lubricant to replacement blocked throat O-rings (key 44) and back-up rings (key 45).
13. Apply lubricant to the replacement stem O-ring (key 11) and stem back-up rings (key 12) and install them on the stem (key 10).
14. For assembly, lubricate the stem (key 10) and insert the diaphragm casing (key 5) and hook it on the lever (key 15).
15. Lubricate the contact points of the lever (key 15).
16. Insert parts into the diaphragm casing (key 5) that were removed in steps 5 and 6 or step 10 (see Figure 5).
17. Install the disk assembly (key 9), line up the hole in the disk assembly and stem (key 10) and insert the hair pin clip (key 13).
18. Position the diaphragm casing (key 5) plus attached parts in relation to the body (key 1) so that they are correct for the application.
19. Secure the diaphragm casing (key 5) to the body with the cap screws (key 3, Figure 5). For an aluminum diaphragm casing, torque the cap screws (key 3) to 16 ft-lbs / 22 N•m. For ductile iron or steel diaphragm casings, torque the cap screws (key 3) to 25 ft-lbs / 34 N•m.

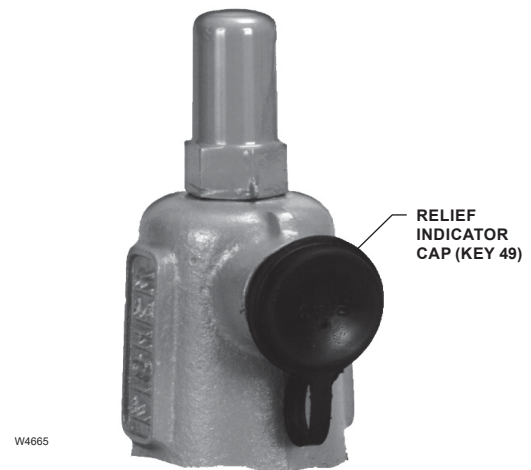

Figure 4. Relief Indicator

20. It may be necessary to reposition the diaphragm spring case to prevent rain, ice and foreign debris from entering the spring case. Refer to the Diaphragm and Spring Case Area Maintenance Procedures, steps 1, 2 and 21 through 25.

Diaphragm and Spring Case Area Maintenance Procedures

These procedures are for gaining access to the control spring, diaphragm assembly and lever assembly. All spring pressure must be released from the diaphragm casing before these steps can be performed.

While using the following procedures, refer to Figures 7 through 13 for key number locations.

1. Remove the adjusting screw cap (key 36), loosen the lock nut (key 34) and turn the adjusting screw (key 35) counterclockwise until all compression is removed from the control spring (key 32).
2. Remove the spring case cap screws (key 37), the nameplates and lift off the spring case (key 29). If changing the control spring (key 32) or repositioning the spring case (key 29) is the only maintenance required, install the replacement control spring or rotate the spring case so it is correct for the application. Skip to step 21. For diaphragm area maintenance, continue with step 3.
3. Remove the diaphragm limiter O-ring and diaphragm limiter (keys 51 and 50, on the Type 627H or 627HM only). Remove the diaphragm assembly by tilting it so that the pusher post (key 19) slips off the lever (key 15).
4. If it is necessary to replace the lever assembly, remove the lever cap screws (key 18).

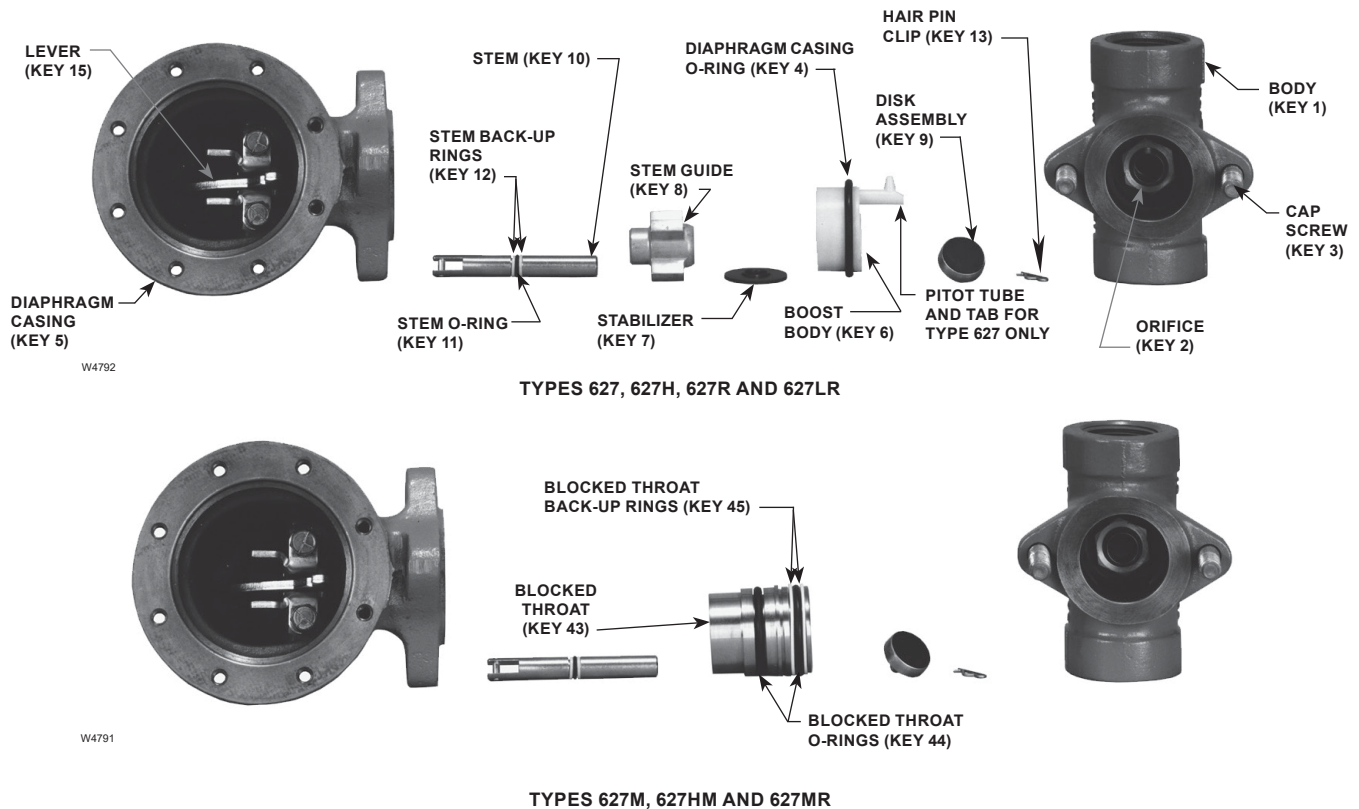

Figure 5. Stem Assemblies

5. Install the replacement lever (key 15) into the lever retainer (key 16) by inserting the lever pin (key 17). Secure the lever assembly into the diaphragm casing with the cap screws (key 18) and torque the cap screws to 7 ft-lbs / 9.5 N•m.

If it is necessary to perform maintenance on the diaphragm assembly, continue with steps 6 through 11 and step 20 for Types 627, 627H, 627M, 627HM and all 627OSX variations regulators or steps 12 through 19 for Types 627R, 627LR and 627MR regulators.

Perform steps 6 through 11 for Types 627, 627H, 627M, 627HM and all 627OSX variations Regulators only:

6. For Types 627, 627H, 627M and 627HM regulators (Figures 5 and 6), use steps 7 through 11 to disassemble and reassemble the diaphragm assembly.
7. Remove the diaphragm head cap screw (key 46), lower spring seat (key 31, Type 627 or 627M only) and diaphragm head (key 24). On the Type 627H or 627HM, remove the pusher post O-rings (key 52). Separate the diaphragm (key 23) from the pusher post (key 19).
8. Install the diaphragm (key 23), in reverse order in step 7, on the pusher post (key 19), insert and finger tighten the diaphragm head cap screw (key 46).

9. Hook the pusher post on the lever (key 15), then turn the diaphragm (key 23) to match the holes in the diaphragm with the holes in the spring casing.
10. Unhook the pusher post from the lever (key 15) and torque the diaphragm head cap screw (key 46) to 7 ft-lbs / 9.5 N•m for the Type 627 or 627M. On the Type 627H or 627HM, torque the diaphragm head cap screw to 14 ft-lbs / 19 N•m.
11. Hook the pusher post on the lever (key 15) and check the hole alignment. If necessary, loosen the cap screw (key 46) and reposition the diaphragm (key 23) on the pusher post (key 19). Retorque the screw (see step 10). Skip to step 20.

Perform steps 12 through 19 for Types 627R, 627LR and 627MR Regulators only:

12. For Types 627R, 627LR and 627MR regulators (Figure 6), use steps 13 through 19 to disassemble and reassemble the diaphragm assembly.
13. Remove the guide retainer (key 26) and separate the diaphragm parts. Refer to Figure 6 for the sequence of parts.

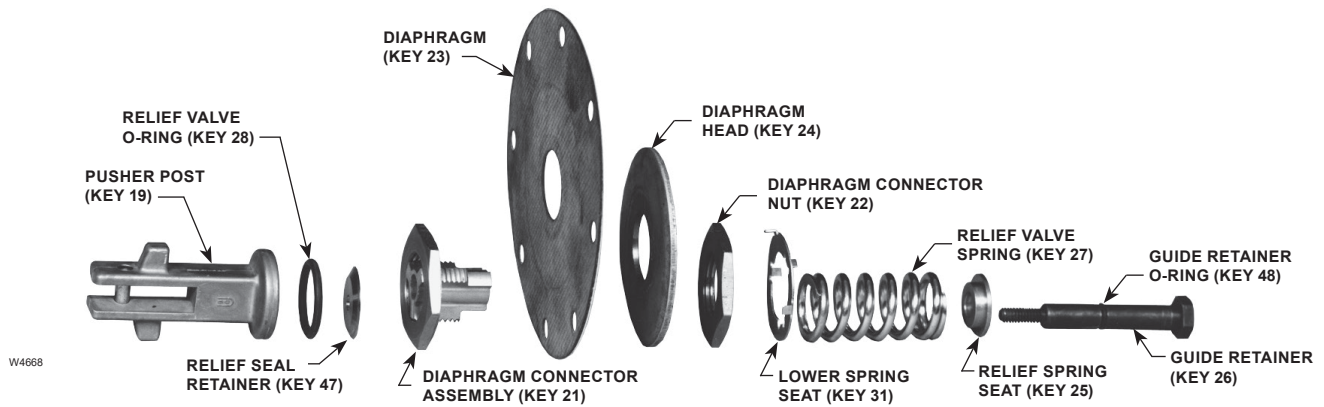

TYPE 627, 627R, 627LR, 627M OR 627MR

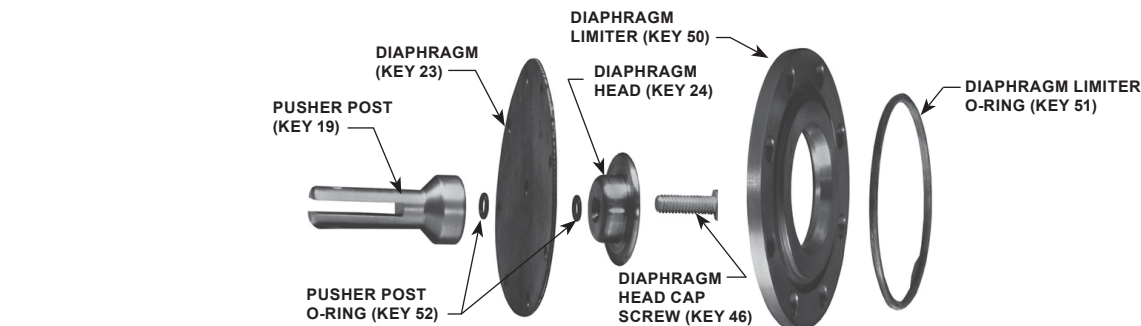

TYPES 627H AND 627HM

Figure 6. Diaphragm Assemblies

14. To remove the diaphragm (key 23), remove the diaphragm connector nut (key 22) and lift off the diaphragm head (key 24) and diaphragm (key 23) from the connector assembly (key 21). Do not attempt to disassemble the connector assembly (key 21).
15. Position the replacement diaphragm (key 23) on the connector assembly (key 21), install the diaphragm head (key 24) and connector nut (key 22), then torque to 17 ft-lbs / 23 N•m.
16. If necessary, replace the guide retainer O-ring (key 48) and, set the guide retainer (key 26) aside, ready for assembly.
17. On the pusher post (key 19) install the relief seal O-ring (key 28) and apply lubricant. Also, install the relief seal retainer (key 47), diaphragm connector assembly (key 21, with attached parts) relief spring (key 27), upper relief spring seat (key 33) and guide retainer (key 26). Torque the guide retainer (key 26) to 3 ft-lbs / 4.1 N•m.
18. Hook the pusher post (key 19) (with attached parts) on the lever (key 15) to check the alignment of the holes in the diaphragm with the holes in the spring casing. If the holes do not line up, unhook the pusher post from the lever, hold the pusher post and rotate the diaphragm to the correct position.
19. Install the lower spring seat (key 31) over the relief spring so it rests flat on the connector nut (key 22).
20. Insert the diaphragm assembly into the diaphragm casing (key 5) and hook the pusher post on the lever (key 15).
21. Install the control spring (key 32) and upper spring seat (key 33) and apply lubricant to the upper spring seat (key 33).
22. Install the spring case (key 29) so that the screened vent assembly (key 30) is in the correct position for the application. Place the nameplates over the screw holes, insert the spring case cap screws (key 37) and finger tighten.
23. Screw in the adjusting screw (key 35) to put slack into the diaphragm (key 23).

627 Series

24. Using a crisscross pattern, finish tightening the spring case cap screws (key 37) to 7 ft-lbs / 9.5 N•m of torque.
25. If necessary, refer to the installation and/or the Startup and Adjustment procedures.
26. Install the adjusting locknut (key 34) after regulator adjustment.

Parts Ordering

When corresponding with your local Sales Office about this equipment, always reference the equipment serial number or FS number that can be found on the nameplate.

When ordering replacement parts, reference the key number of each needed part as found in the following parts list. Separate kits containing all recommended spare parts are available.

See Type OS2 Instruction Manual (D102778X012) for slam-shut parts.

Parts List

Note

In this parts list, parts marked NACE are intended for corrosion-resistant service as detailed in the NACE International Standard MR0175.

Key	Description	Part Number
1	Body ⁽¹⁾	
	Ductile iron	
	1000 psig / 69.0 bar maximum inlet pressure	
	3/4 NPT	30B3046X012
	1 NPT	30B3048X012
	1-1/4 NPT	ERAA42554A0
	2 NPT	30B3096X012
	Ductile iron (Long Body)	
	1000 psig / 69.0 bar maximum inlet pressure	
	1 NPT	39B2451X012
	2 NPT	39B0414X012
	Steel	
	2000 psig / 138 bar maximum inlet pressure	
	3/4 NPT	30B3050X012
	1 NPT	30B3051X012
	2 NPT	30B7452X012
	Steel (Long Body)	
	2000 psig / 138 bar maximum inlet pressure	
	1 NPT	39B0412X012
	2 NPT	39B0415X012
	Steel, CL600 RF flanged	
	1500 psig / 103 bar maximum inlet pressure	
	NPS 1 / DN 25	40B6754X012
	NPS 2 / DN 50	40B6756X012
	Steel, CL300 RF flanged	
	750 psig / 51.7 bar maximum inlet pressure	
	NPS 1 / DN 25	41B8978X012
	NPS 2 / DN 50	41B8080X012
	Steel, CL150 RF flanged	
	290 psig / 20.0 bar maximum inlet pressure	
	NPS 1 / DN 25	43B8656X022
	NPS 2 / DN 50	44B0666X012
	Steel, BWE	
	1000 psig / 69.0 bar maximum inlet pressure	
	NPS 1 / DN 25	33B6723X012
	NPS 2 / DN 50	38B1688X012
	Steel, PN 16/25/40 RF	
	580 psig / 40.0 bar maximum inlet pressure	
	NPS 1 / DN 25	44B0386X012
	NPS 2 / DN 50	44B3342X012
	Stainless Steel ⁽²⁾ , NPT	
	2000 psig / 138 bar maximum inlet pressure	
	3/4 NPT	30B3050X062
	1 NPT	30B3051X092
	2 NPT	30B7452X052
	Stainless Steel ⁽²⁾ , CL150 RF flanged	
	275 psig / 18.9 bar maximum inlet pressure	
	NPS 1 / DN 25	43B8656X052
	NPS 2 / DN 50	44B0666X022
	Stainless Steel ⁽²⁾ , CL300 RF flanged	
	720 psig / 49.6 bar maximum inlet pressure	
	NPS 1 / DN 25	41B8978X072
	NPS 2 / DN 50	41B8080X072
	Stainless Steel ⁽²⁾ , CL600 RF flanged	
	1440 psig / 99.2 bar maximum inlet pressure	
	NPS 1 / DN 25	40B6754X102
	NPS 2 / DN 50	40B6756X062
	Stainless Steel ⁽²⁾ , PN 16/25/40 RF	
	580 psig / 40.0 bar maximum inlet pressure	
	NPS 1 / DN 25	44B0386X032
	NPS 2 / DN 50	44B3342X032
	Type 627OSX Bodies, Steel	
	Without Tap	
	NPS 1 / DN 25	
	NPT	ERAA33145A0
	SWE	ERAA31302A0
	CL150 RF	ERAA44998A0
	CL300 RF	ERAA45039A0
	CL600 RF	ERAA45040A0
	NPS 2 / DN 50	
	NPT	ERAA33146A0
	SWE	ERAA32902A0
	CL150 RF	ERAA45027A0
	CL300 RF	ERAA45029A0
	CL600 RF	ERAA45031A0
	With Tap	
	NPS 1 / DN 25	
	NPT	ERAA34615A0
	SWE	ERAA34616A0
	CL150 RF	ERAA45033A0
	CL300 RF	ERAA45038A0
	CL600 RF	ERAA45041A0
	NPS 2 / DN 50	
	NPT	ERAA34618A0
	SWE	ERAA34619A0
	CL150 RF	ERAA45028A0
	CL300 RF	ERAA45030A0
	CL600 RF	ERAA45032A0

*Recommended spare part.

1. Bodies can be used for both standard and NACE constructions.

2. Stainless steel body material can be used for applications in temperature ranges down to -40°F / -40°C and are only available for Types 627, 627R and 627H.

Key	Description	Part Number	Key	Description	Part Number
2*	Orifice Aluminum 3/32 in. / 2.4 mm 1/8 in. / 3.2 mm 3/16 in. / 4.8 mm 1/4 in. / 6.4 mm 3/8 in. / 9.5 mm 1/2 in. / 13 mm 303 Stainless steel 3/32 in. / 2.4 mm 1/8 in. / 3.2 mm 3/16 in. / 4.8 mm 1/4 in. / 6.4 mm 3/8 in. / 9.5 mm 1/2 in. / 13 mm 316 Stainless steel, NACE construction only 3/32 in. / 2.4 mm 1/8 in. / 3.2 mm 3/16 in. / 4.8 mm 1/4 in. / 6.4 mm 3/8 in. / 9.5 mm 1/2 in. / 13 mm	0R044109022 1A936709012 00991209012 0B042009012 0B042209012 1A928809012 0R044135032 1A936735032 00991235032 0B042035032 0B042235032 1A928835032 0R0441X0012 1A9367X0022 009912X0012 0B0420X0012 0B0422X0012 1A9288X0012	8	Stem Guide (for Types 627, 627H, 627R and 627LR only), Powdered metal	20B3061X012
			9*	Disk Assembly (for all Orifice Size) Aluminum holder and Nitrile (NBR) disk 303 Stainless steel holder and Nitrile (NBR) disk Aluminum holder and Nylon (PA) disk 303 Stainless steel holder and Nylon (PA) disk 316 Stainless steel holder and Nylon (PA) disk 316 Stainless steel holder and Nitrile (NBR) disk 303 Stainless steel holder and Fluorocarbon (FKM) disk Aluminum holder and Fluorocarbon (FKM) disk 316 Stainless steel holder and Fluorocarbon (FKM) disk	1C4248X0212 1C4248X0202 1C4248X00A2 1C4248X0062 1C4248X0262 1C4248X0252 1C4248X0052 1C4248X0182 1C4248X0192
			10	Stem 303 Stainless steel 316 Stainless steel (NACE)	10B3059X012 10B3059X022
			11*	Stem O-ring Nitrile (NBR) Fluorocarbon (FKM) For Types 627, 627R, 627LR, 627M and 627MR only	1D687506992 1N430406382
			12*	Stem Back-up Ring, Polytetrafluoroethylene (PTFE) (2 required)	1K786806992
3	Cap Screw (not shown), (2 required) 627 Series For Ductile iron/Steel diaphragm case For Aluminum diaphragm case (not applicable for Types 627H and 627HM) Type 627 Only For Ductile iron/Steel diaphragm case For Aluminum case with Steel diaphragm case For SST Case and body For Aluminum Case and SST body Type 627OSX Only For Steel Casings For Ductile Iron Casings	1A560724052 1A352524052 1A5607X0052 10A3869X012 1A5607X0052 10A3869X022 1A560724052 GF05446X572	13	Hair Pin Clip, Stainless steel	10B3058X012
			14	Drive Pin, Plated steel	1H3671X0012
			15	Lever, Plated steel	20B3063X012
			16	Lever Retainer, Plated steel	30B3097X012
			17	Lever Pin Stainless steel 316 Stainless steel (NACE)	10B3083X012 10B3083X022
			18	Lever Cap Screw (2 required) Plated steel 316 Stainless steel (NACE)	10B7454X012 1B2905X0012
			19	Pusher Post, Aluminum For Type 627 or 627M For Type 627R, 627LR or 627MR For Type 627H or 627HM, 416 Stainless steel Stainless steel (NACE)	10B3098X012 10B3098X022 10B3098X032 10B3098X102
			21	Diaphragm Connector (for Type 627R, 627LR or 627MR only), Stainless steel	28B8832X012
			22	Diaphragm Connector Nut (for Type 627R, 627LR or 627MR only), Stainless steel	10B7449X012
4*	Diaphragm Case O-ring Nitrile (NBR) For Type 627, 627H or 627R only Fluorocarbon (FKM) For Types 627, 627R and 627LR only	17A2325X022 10A0037X012	23*	Diaphragm Nitrile (NBR) For Type 627 or 627M with Aluminum or Ductile iron diaphragm case For Type 627 or 627M with Steel diaphragm case For Type 627R, 627LR or 627MR with Aluminum or Ductile iron diaphragm case For Type 627R, 627LR or 627MR with Steel diaphragm case For Type 627H or 627HM with Steel diaphragm case (diaphragm is Neoprene (CR) with Nylon (PA) fabric) Fluorocarbon (FKM) For Types 627R, 627LR and 627MR with Steel case For Types 627 and 627M with Steel case For Types 627R, 627LR and 627MR with Ductile Iron and Aluminum Casing For Types 627 and 627M with Ductile Iron and Aluminum Casing	10B3069X012 10B8735X012 10B3068X012 10B8736X012 12B0178X012 10B8736X022 10B8735X042 10B3068X022 10B3069X032
5	Diaphragm Case For Type 627, 627R or 627LR Aluminum without 1/8 in. / 3.2 mm gauge tap Aluminum with 1/8 in. / 3.2 mm gauge tap for 627 Series (except Types 627H and 627HM) Ductile iron without 1/8 in. / 3.2 mm gauge tap Ductile iron with 1/8 in. / 3.2 mm gauge tap for 627 Series (except Types 627H and 627HM) For Type 627, 627R or 627LR Steel Ductile iron with 1/4 NPT gauge tap for 627 Series (except Types 627H and 627HM) Steel with 1/4 NPT gauge tap for 627 Series (except Type 627H) For Type 627M or 627MR Ductile iron Steel For Type 627H, Steel For Type 627, Stainless steel For Type 627HM, Steel	40B3084X012 11B5380X012 30B3053X012 31B0641X012 30B3104X012 39A5987X012 30B8734X012 39A5987X012 30B8734X012 30B3104X012 30B3104X082 30B8734X012	21	Diaphragm Connector (for Type 627R, 627LR or 627MR only), Stainless steel	28B8832X012
			22	Diaphragm Connector Nut (for Type 627R, 627LR or 627MR only), Stainless steel	10B7449X012
			23*	Diaphragm Nitrile (NBR) For Type 627 or 627M with Aluminum or Ductile iron diaphragm case For Type 627 or 627M with Steel diaphragm case For Type 627R, 627LR or 627MR with Aluminum or Ductile iron diaphragm case For Type 627R, 627LR or 627MR with Steel diaphragm case For Type 627H or 627HM with Steel diaphragm case (diaphragm is Neoprene (CR) with Nylon (PA) fabric) Fluorocarbon (FKM) For Types 627R, 627LR and 627MR with Steel case For Types 627 and 627M with Steel case For Types 627R, 627LR and 627MR with Ductile Iron and Aluminum Casing For Types 627 and 627M with Ductile Iron and Aluminum Casing	10B3069X012 10B8735X012 10B3068X012 10B8736X012 12B0178X012 10B8736X022 10B8735X042 10B3068X022 10B3069X032
6	Boost Body (not for Type 627M, 627HM or 627MR), Delrin® For Type 627 or 627H For Type 627R or 627LR	30B3056X012 30B3057X012	24	Diaphragm Head, Plated steel For Type 627 or 627M, Plated steel For Type 627R, 627LR or 627MR, Plated steel For Type 627H or 627HM, 416 Stainless steel	1D666428982 10B3071X012 12B0175X012
7	Stabilizer Nitrile (NBR) For Types 627, 627H, 627R and 627LR only Fluorocarbon (FKM) For Types 627, 627R and 627LR only	10B3060X012 10B3060X022			

*Recommended spare part.

Delrin® is a mark owned by E.I. du Pont de Nemours and Co.

627 Series

Key	Description	Part Number	Key	Description	Part Number
25	Relief Spring Seat (For Type 627R or 627MR only), Steel	10B7446X012	36	Adjusting Screw Cap, Plastic	20B3082X012
26	Guide Retainer (For Type 627R, 627LR or 627MR only), Stainless steel	10B7450X012	37	Spring Case Cap Screw, Plated steel (8 required)	
27	Relief Spring (For Type 627R or 627MR only), Plated steel	10B6757X012		For Aluminum or ductile iron diaphragm case	1A391724052
	For Type 627LR	1B541327022		For Steel diaphragm case	1A368324052
28*	Relief Seal O-ring			For Stainless steel case and body	1A3683X0062
	Nitrile (NBR)			For Aluminum case and SST body	1A3917X0062
	For Type 627R, 627LR or 627MR only	1J108506992		For Type 627H/HM, steel diaphragm case	1A346424052
	Fluorocarbon (FKM)			For Type 627H, Stainless steel case and body	1A3464X0022
	For Types 627R, 627LR and 627MR only	1J1085X0042	43	Blocked Throat (For Type 627M, 627HM or 627MR only), Stainless steel	10B3085X012
29	Spring Case		44*	Blocked Throat O-ring	
	For Type 627, 627R or 627LR			Nitrile (NBR) For Type 627M, 627HM or 627MR only (2 required)	1E264306992
	Aluminum	40B3086X012		Fluorocarbon (FKM)	
	Ductile iron	30B3055X012		For Types 627M and 627MR only	1E2643X0022
	Steel	30B3102X012	45*	Blocked Throat Back-up Ring (For Type 627M, 627HM or 627MR only), PTFE (2 required)	10B3106X012
	Stainless steel (Types 627 and 627R only)	30B3102X092	46	Diaphragm Head Cap Screw, Steel	
29	Spring Case (continued)			For Type 627 or 627M	1B290524052
	For Type 627M or 627MR			For Type 627H or 627HM	1C379124052
	Ductile iron	30B3055X012	47	Relief Seal Retainer (For Type 627R, 627LR or 627MR only), Stainless steel	10B7445X012
	Steel	30B3102X012	48*	Guide Retainer O-ring	
	For Type 627H or 627HM			Nitrile (NBR)	
	Steel	30B3102X012		For Type 627R, 627LR or 627MR only	1D682506992
	Stainless steel (Type 627H only)	30B3102X092		Fluorocarbon (FKM)	
30	Screened Vent Assembly, Plastic	10B3093X012		For Types 627R, 627LR and 627MR only	1N423906382
31	Lower Spring Seat, Plated steel		49	Relief Indicator (For Type 627R, 627LR or 627MR only), Rubber (not shown)	30B3100X012
	For Type 627 or 627M	1D666625072	50	Diaphragm Limiter	
	For Type 627R, 627LR or 627MR	20B3073X012		(For Types 627H and 627HM only)	22B0176X012
32	Control Spring, Plated steel		51*	Diaphragm Limiter O-ring	
	5 to 20 psig / 0.34 to 1.4 bar, Yellow	10B3076X012		For Types 627H and 627HM only	1K877606992
	15 to 40 psig / 1.0 to 2.8 bar, Green	10B3077X012	52*	Pusher Post O-ring (2 required)	
	35 to 80 psig / 2.4 to 5.5 bar, Blue	10B3078X012		For Types 627H and 627HM only	1C853806992
	70 to 150 psig / 4.8 to 10.3 bar, Red	10B3079X012	58	Pipe Plug, Zinc	1D8293T0022
	140 to 250 psig range / 9.7 to 17.2 bar, Blue, used for Type 627H or 627HM	10B3078X012	67	Drive Screw, 18-8 Stainless steel	1A368228982
	240 to 500 psig range / 16.5 to 34.5 bar, Red, used for Type 627H or 627HM	10B3079X012	72	Pipe Plug, Zinc-plated steel	1A767524662
33	Upper Spring Seat, Plated steel	1D667125072	75*	Slam-shut seat	ERAA32884A0
34	Locknut, Plated steel	1D667728982	76*	O-ring	GE29958X012
35	Adjusting Screw, Plated steel				
	For Type 627, 627M, 627H or 627HM	10B3081X012			
	For Type 627R, 627LR or 627MR	10B3080X012			

*Recommended spare part.

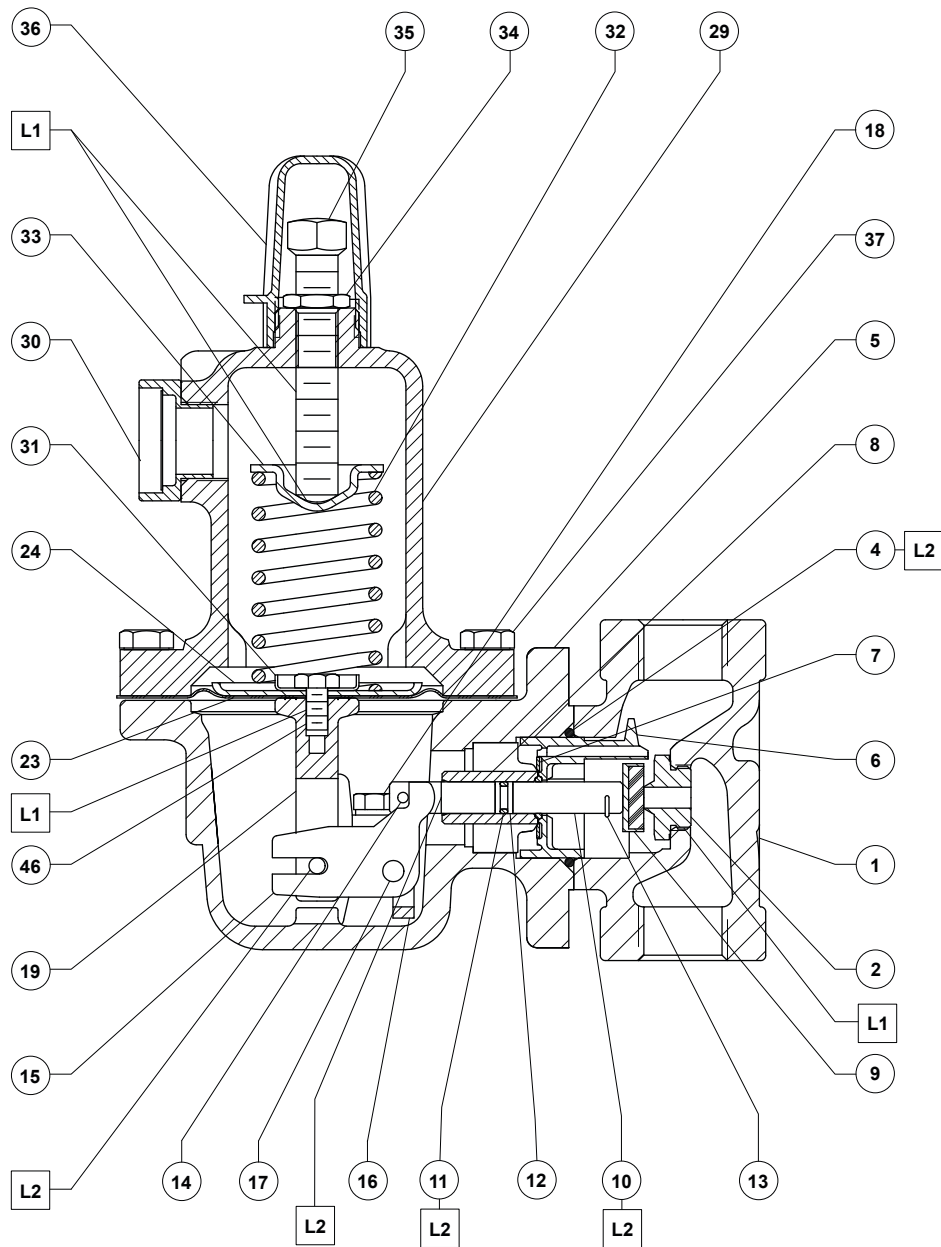

30B3092_G

- APPLY LUBRICANT⁽¹⁾
- L1 = MULTI-PURPOSE LITHIUM POLYMER TYPE GREASE
- L2 = EXTREME LOW-TEMPERATURE BEARING GREASE
- PARTS NOT SHOWN: 3

1. Lubricants must be selected such that they meet the temperature requirements.

Figure 7. Type 627 Regulator Assembly

627 Series

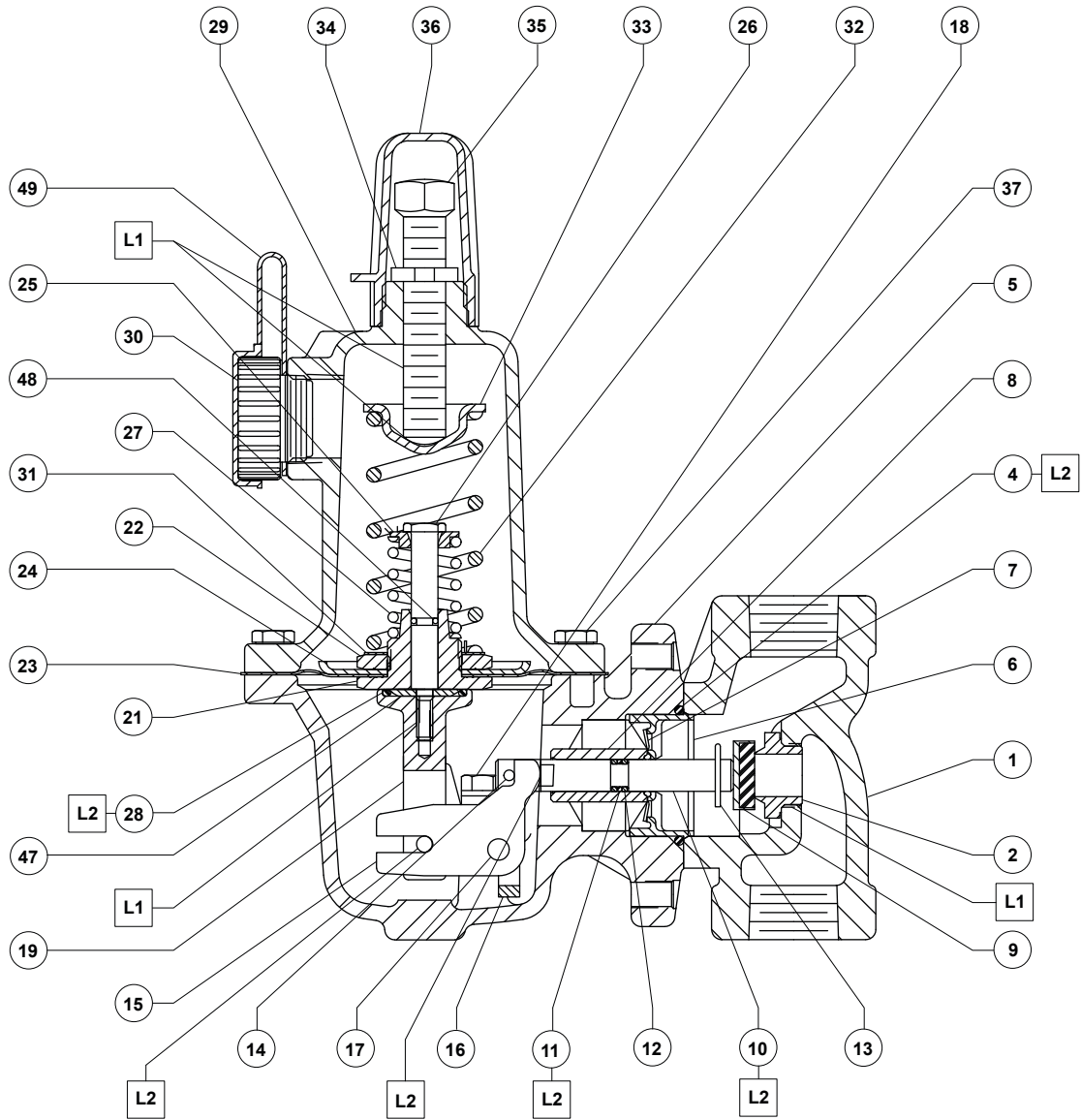

30B3089_G

- APPLY LUBRICANT⁽¹⁾
- L1 = MULTI-PURPOSE LITHIUM POLYMER TYPE GREASE
- L2 = EXTREME LOW-TEMPERATURE BEARING GREASE
- PARTS NOT SHOWN: 3

1. Lubricants must be selected such that they meet the temperature requirements.

Figure 8. Type 627R Regulator Assembly

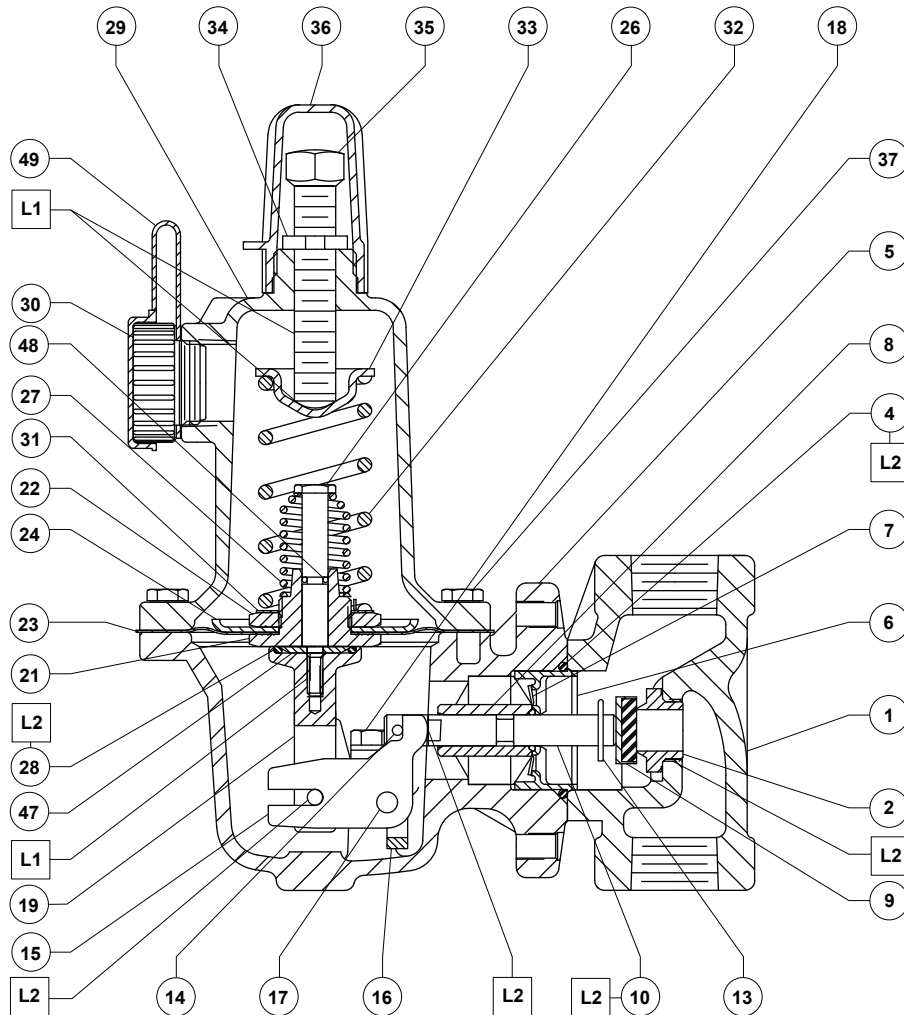

38B4843_C

- APPLY LUBRICANT⁽¹⁾
- L1 = MULTI-PURPOSE LITHIUM POLYMER TYPE GREASE
- L2 = EXTREME LOW-TEMPERATURE BEARING GREASE
- PARTS NOT SHOWN: 3

1. Lubricants must be selected such that they meet the temperature requirements.

Figure 9. Type 627LR Regulator Assembly

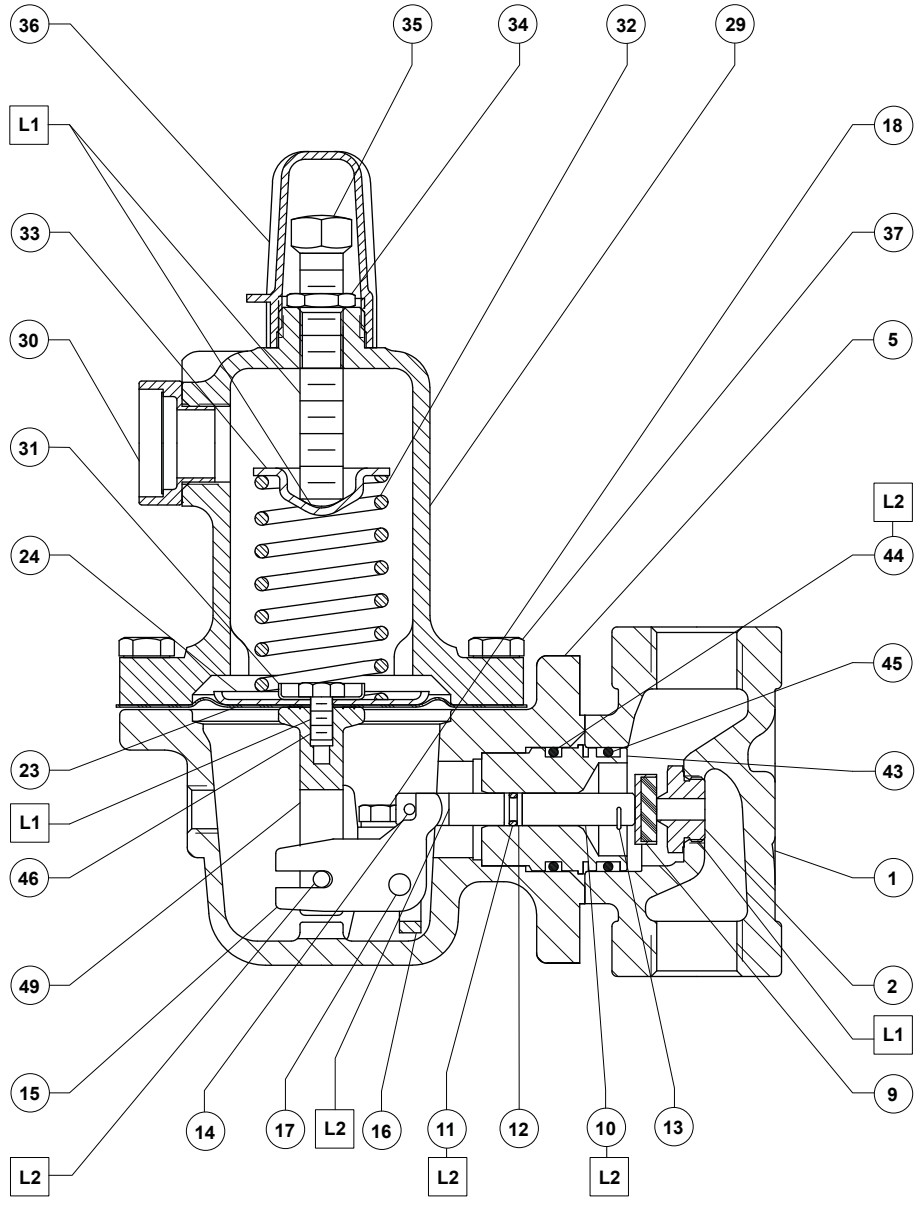

30B6433_E

- APPLY LUBRICANT⁽¹⁾
- L1 = MULTI-PURPOSE LITHIUM POLYMER TYPE GREASE
- L2 = EXTREME LOW-TEMPERATURE BEARING GREASE
- PARTS NOT SHOWN: 3

1. Lubricants must be selected such that they meet the temperature requirements.

Figure 10. Type 627M Regulator Assembly

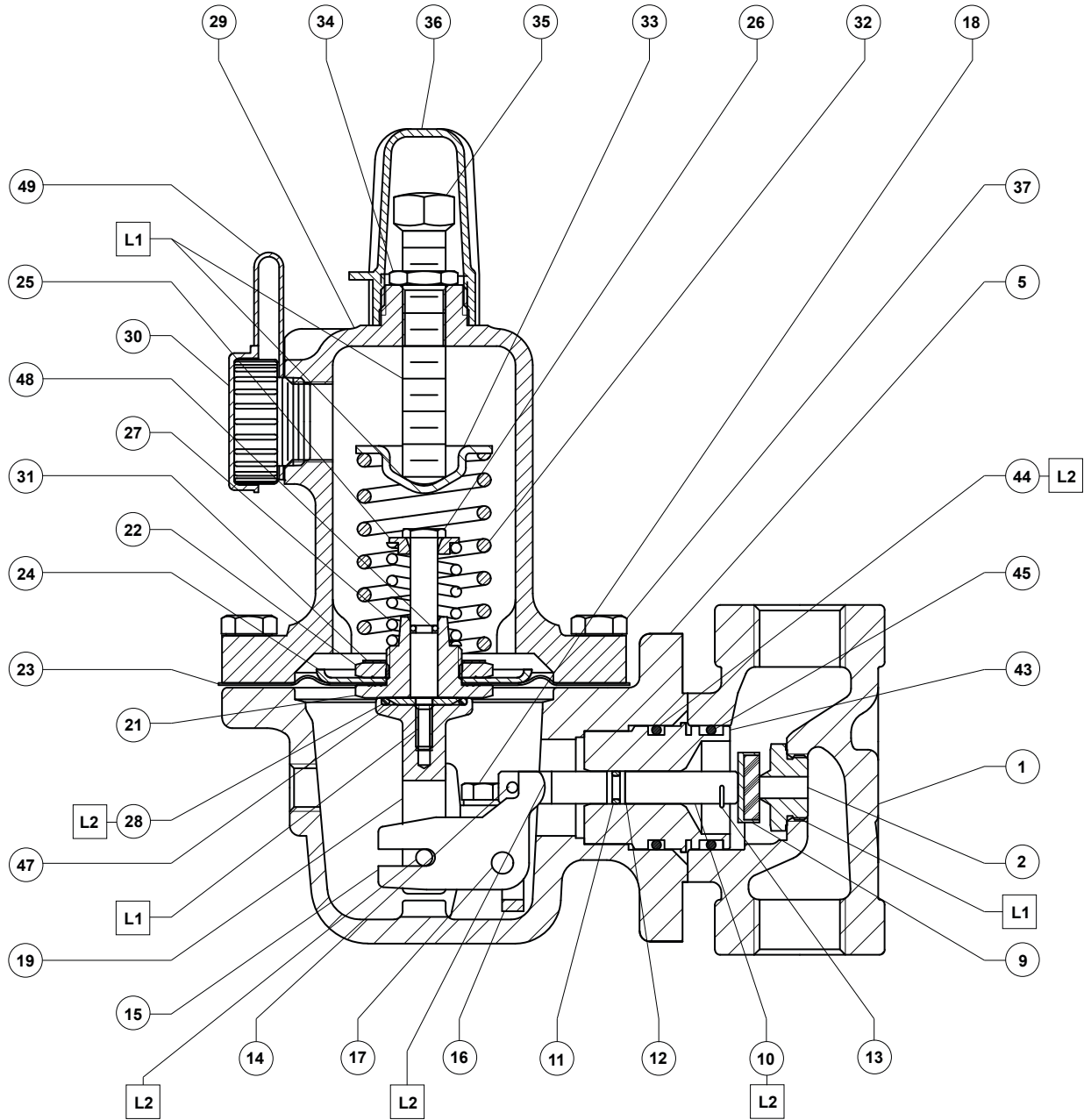

30B6434_E

- APPLY LUBRICANT⁽¹⁾
- L1 = MULTI-PURPOSE LITHIUM POLYMER TYPE GREASE
- L2 = EXTREME LOW-TEMPERATURE BEARING GREASE
- PARTS NOT SHOWN: 3

1. Lubricants must be selected such that they meet the temperature requirements.

Figure 11. Type 627MR Regulator Assembly

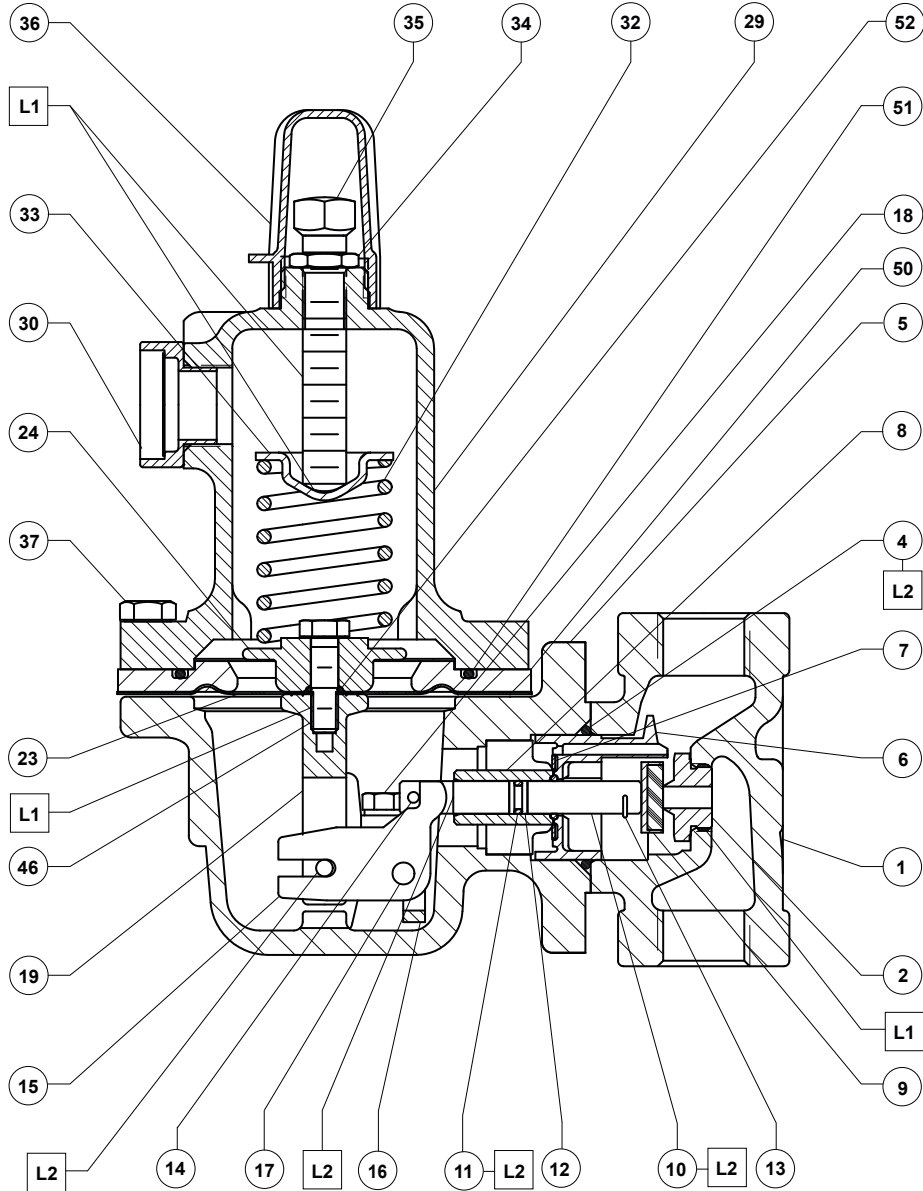

31B5374_D

- APPLY LUBRICANT⁽¹⁾
- L1 = MULTI-PURPOSE LITHIUM POLYMER TYPE GREASE
- L2 = EXTREME LOW-TEMPERATURE BEARING GREASE
- PARTS NOT SHOWN: 3

1. Lubricants must be selected such that they meet the temperature requirements.

Figure 12. Type 627H Regulator Assembly

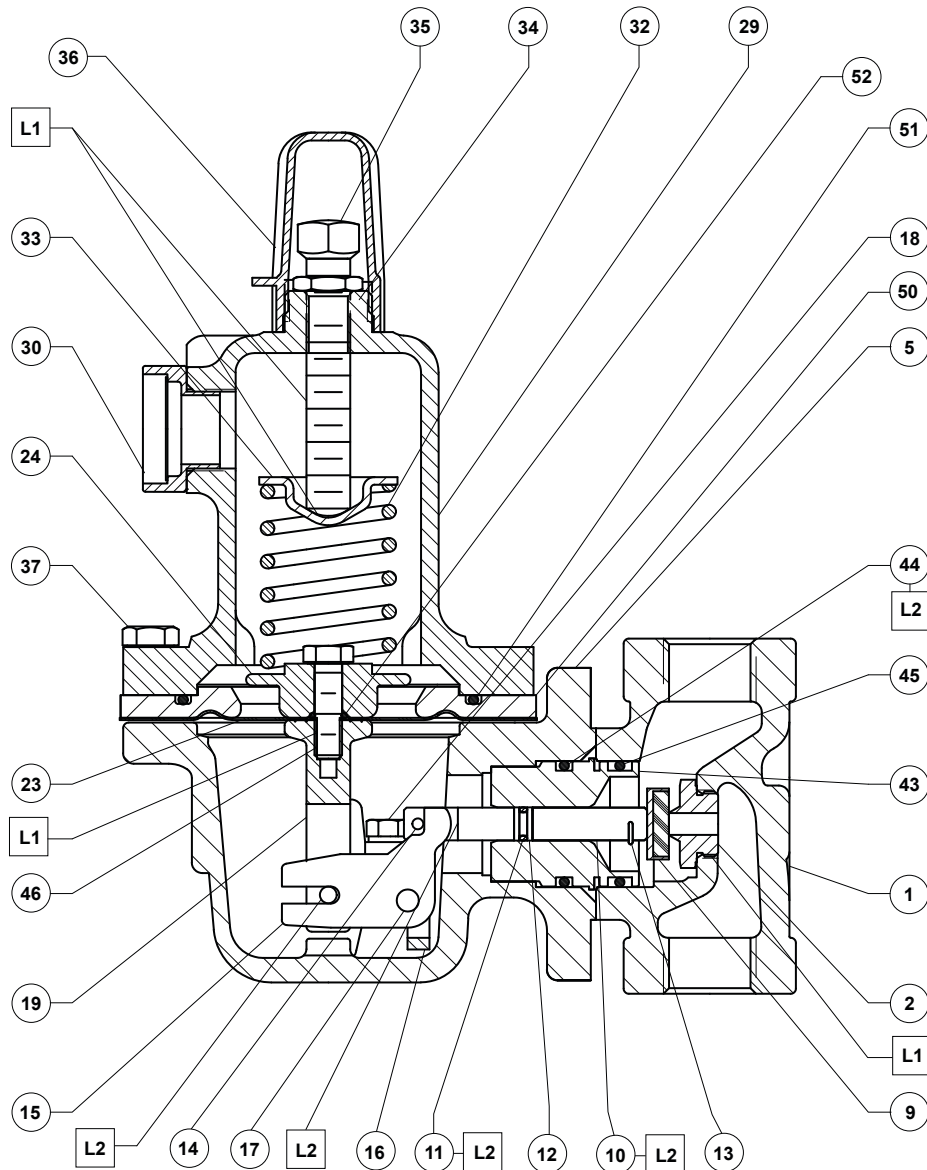

31B9872_D

□ APPLY LUBRICANT⁽¹⁾
 L1 = MULTI-PURPOSE LITHIUM POLYMER TYPE GREASE
 L2 = EXTREME LOW-TEMPERATURE BEARING GREASE
 PARTS NOT SHOWN: 3

1. Lubricants must be selected such that they meet the temperature requirements.

Figure 13. Type 627HM Regulator Assembly

627 Series

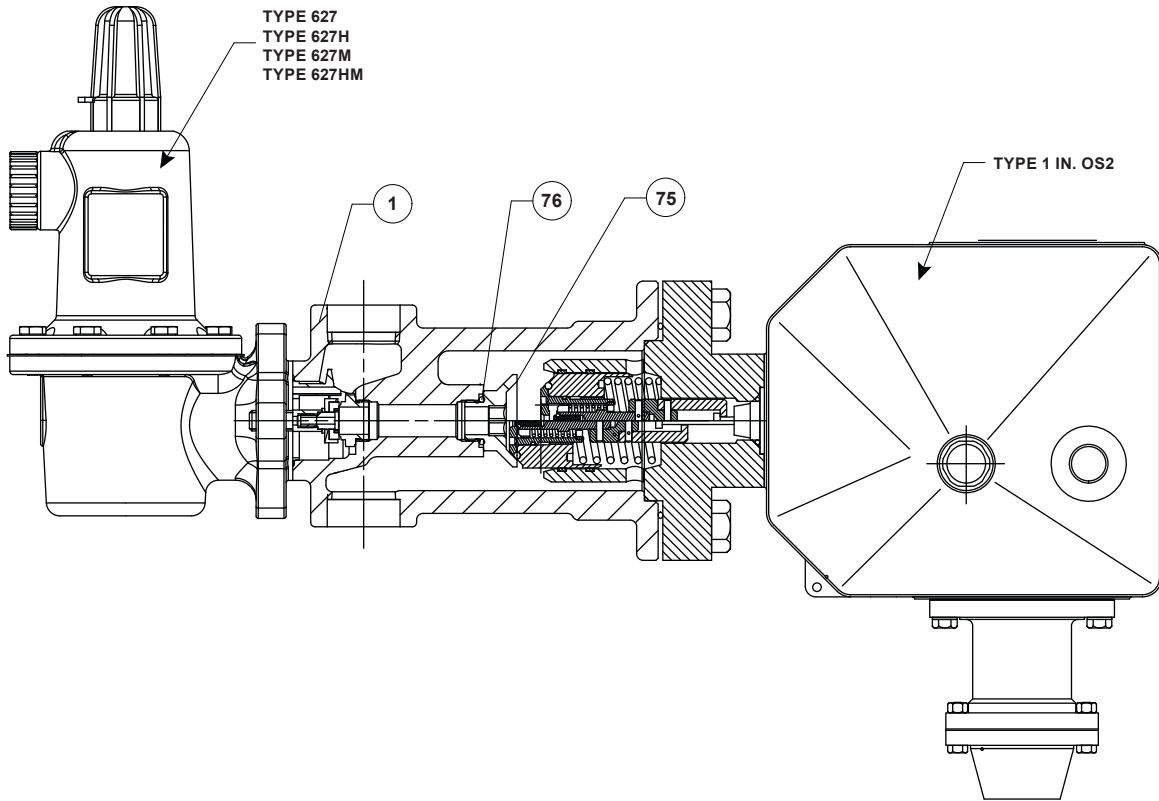

Figure 14. Type 627OSX Regulator Assembly

✉ Webadmin.Regulators@emerson.com

🔍 Fisher.com

📘 Facebook.com/EmersonAutomationSolutions

🌐 LinkedIn.com/company/emerson-automation-solutions

🐦 Twitter.com/emr_automation

Emerson Automation Solutions

Americas

McKinney, Texas 75070 USA
T +1 800 558 5853
+1 972 548 3574

Europe

Bologna 40013, Italy
T +39 051 419 0611

Asia Pacific

Singapore 128461, Singapore
T +65 6777 8211

Middle East and Africa

Dubai, United Arab Emirates
T +971 4 811 8100

D101328X012 © 1986, 2020 Emerson Process Management Regulator Technologies, Inc. All rights reserved. 03/20.

The Emerson logo is a trademark and service mark of Emerson Electric Co. All other marks are the property of their prospective owners. Fisher™ is a mark owned by Fisher Controls International LLC, a business of Emerson Automation Solutions.

The contents of this publication are presented for informational purposes only, and while every effort has been made to ensure their accuracy, they are not to be construed as warranties or guarantees, express or implied, regarding the products or services described herein or their use or applicability. All sales are governed by our terms and conditions, which are available upon request. We reserve the right to modify or improve the designs or specifications of such products at any time without notice.

Emerson Process Management Regulator Technologies, Inc does not assume responsibility for the selection, use or maintenance of any product. Responsibility for proper selection, use and maintenance of any Emerson Process Management Regulator Technologies, Inc. product remains solely with the purchaser.

