

Gas pressure regulators VGBF

Technical Information · GB

2 Edition 07.13



- Pressure regulators for gaseous media for installation in all types of gas appliances
- Design with inlet pressure compensation diaphragm ensures high control accuracy
- High flow rate due to optimal dimensioning
- Internal impulse on VGBF..05
- No breather line required
- EC type-tested and certified
- Certified by Gosstandart under Technical Regulations



krom
schroder

Contents

- Gas pressure regulators VGBF 1
- Contents 2
- 1 Application 3
 - 1.1 Examples of application 4
- 2 Certification 5
- 3 Function 6
- 4 Flow rate 7
 - 4.1 Selection example for VGBF..05 7
 - 4.2 Selection example for VGBF..10 8
 - 4.3 Selection example for VGBF..40 9
- 5 Selection 10
 - 5.1 Type code 10
- 6 Project planning information 11
 - 6.1 Installation 11
 - 6.2 Installation to EN 746-2 11
 - 6.3 Installing the impulse line 11
 - 6.4 Installation to NFPA 86 11
- 7 Accessories 12
 - 7.1 Damping valve 12
- 8 Technical data 13
 - 8.1 Dimensions 14
 - 8.1.1 VGBF with Rp internal thread or with ISO flange 14
 - 8.1.2 VGBF..T with NPT internal thread or with ANSI flange 15
 - 8.2 Spring table 16
- 9 Maintenance cycles 17
- Feedback 18
- Contact 18

1 Application

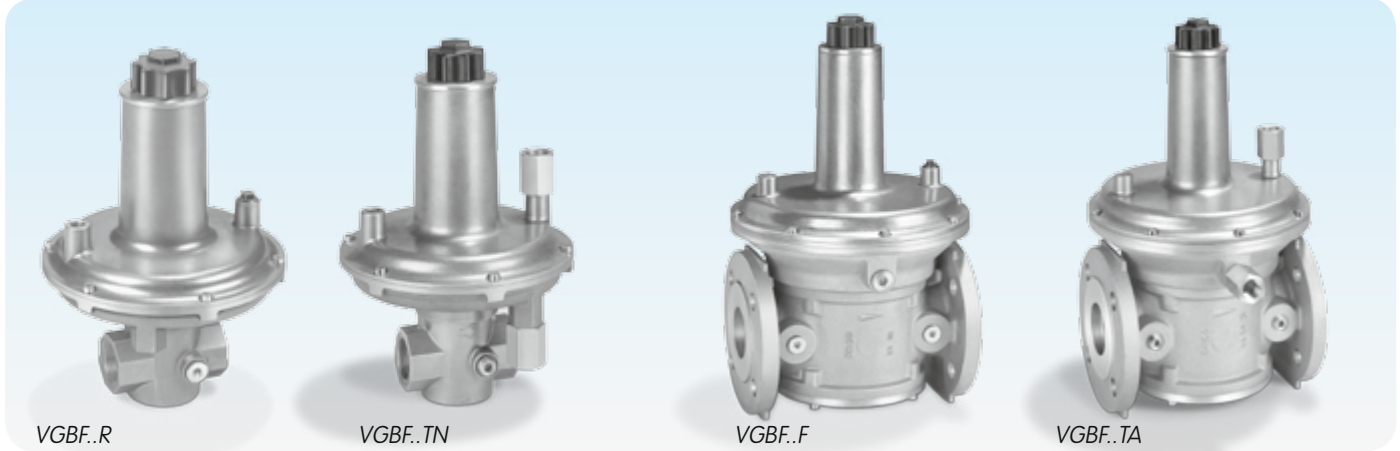

The spring-loaded gas pressure regulator VGBF with inlet pressure compensation diaphragm and zero shut-off serves to maintain the set outlet pressure constant despite changing gas flow rates and inlet pressures in gas pipelines. Thanks to an additional safety diaphragm, no breather line is required, except for installation pursuant to NFPA 86, see page 11 (Installation to NFPA 86) .

For use in gas inlet sections in all sectors of the iron, steel, glass and ceramics industries as well as in commercial heat generation, such as the packaging, paper and foodstuffs industries.

1.1 Examples of application

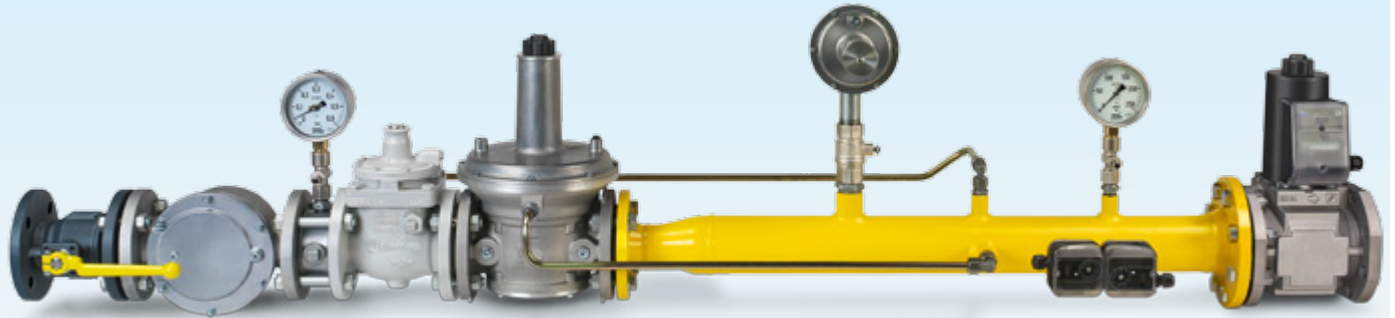

Gas inlet section

2 Certification

EC type-tested and certified



pursuant to

- Gas Appliances Directive (2009/142/EC) in conjunction with DIN EN 88 and DIN 3380.
- Pressure Equipment Directive (97/23/EC) in conjunction with DIN EN 334.

Approval for Russia



Certified by Gosstandart under Technical Regulations.

Approved by Rostekhnadzor (RTN).

Scan of the approval for Russia (RUS) – see www.docuthek.com
→ Elster Kromschroder → Products → 02 Pressure regulators
→ Gas pressure regulators VGBF → Kind of document: Certificate → VGBF B00093 (nationales Zertifikat Russland) (RUS).

3 Function

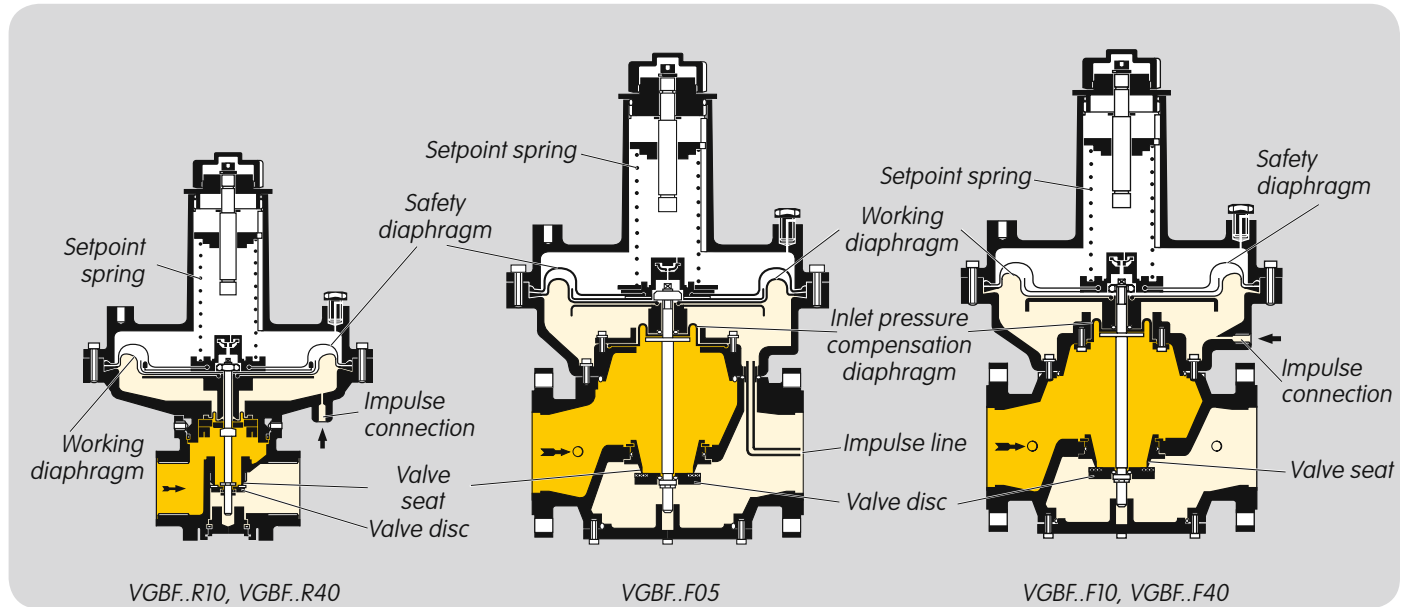

Gas pressure regulator VGBF is open when no pressure is applied.

The gas supply is opened slowly and the gas flows via the open valve seat to the pressure regulator outlet. The outlet pressure is applied to the space beneath the working diaphragm via the impulse line. As soon as the outlet pressure corresponds to the set spring force, the working diaphragm lifts and the valve disc connected to it reduces the flow rate.

If the outlet pressure drops, e.g. due to switching on a consumer, the valve disc is opened further and the outlet pressure increases again.

If the outlet pressure increases, e.g. due to reduced consumption, the valve disc is closed further and the outlet pressure decreases again.

Thus, the outlet pressure is maintained constant despite changing gas flow rates.

If consumption is stopped, the valve disc cuts off the flow completely (zero shut-off).

Fluctuations in the inlet pressure are compensated by the inlet pressure compensation diaphragm.

Pressure test nipples can be installed to measure the inlet and outlet pressures.

4 Flow rate

4.1 Selection example for VGBF..05

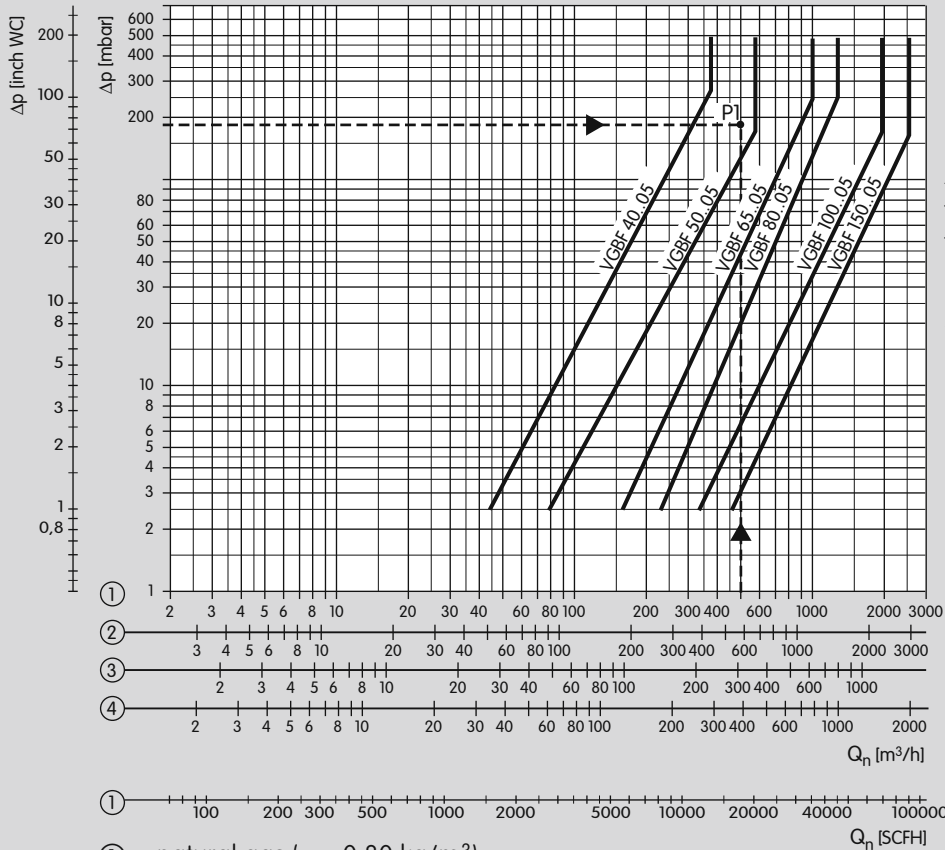

Gas type: natural gas,
 flow rate $Q = 500$ m^3/h ,
 inlet pressure $p_u = 200$ mbar,
 outlet pressure $p_d = 20$ mbar,
 pressure loss
 $\Delta p = p_u - p_d = 180$ mbar.

The result is intersection P1.
 The next largest nominal size is selected: VGBF 50..05.

At a pressure loss of $\Delta p = 180$ mbar,
 the max. flow rate is $Q_{max.}$: 580 m^3/h ,
 the min. flow rate is $Q_{min.}$ derived from
 $Q_{min.} = Q_{max.} \times 10\% = 58$ m^3/h .

- ① = natural gas ($\rho = 0.80$ kg/m^3)
- ② = town gas ($\rho = 0.64$ kg/m^3)
- ③ = LPG ($\rho = 2.01$ kg/m^3)
- ④ = air ($\rho = 1.29$ kg/m^3)

4.2 Selection example for VGBF..10

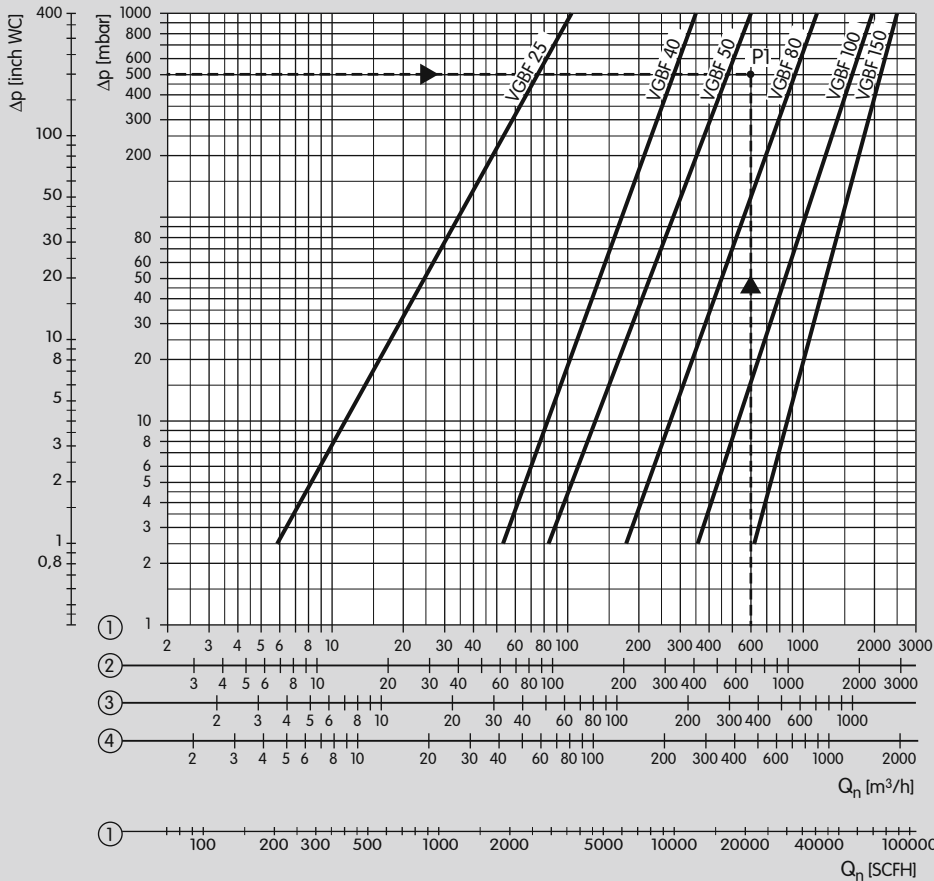

Gas type: natural gas,
 flow rate $Q = 600 \text{ m}^3/\text{h}$,
 inlet pressure $p_u = 600 \text{ mbar}$,
 outlet pressure $p_d = 100 \text{ mbar}$,
 pressure loss $\Delta p = p_u - p_d = 500 \text{ mbar}$.

The result is intersection P1.
 The next largest nominal size is selected: VGBF 80..10.

At a pressure loss of $\Delta p = 500 \text{ mbar}$,
 the max. flow rate is $Q_{\text{max.}}: 910 \text{ m}^3/\text{h}$,
 the min. flow rate is $Q_{\text{min.}}$, derived from
 $Q_{\text{min.}} = Q_{\text{max.}} \times 10\% = 91 \text{ m}^3/\text{h}$.

- ① = natural gas ($\rho = 0.80 \text{ kg/m}^3$)
- ② = town gas ($\rho = 0.64 \text{ kg/m}^3$)
- ③ = LPG ($\rho = 2.01 \text{ kg/m}^3$)
- ④ = air ($\rho = 1.29 \text{ kg/m}^3$)

4.3 Selection example for VGBF..40

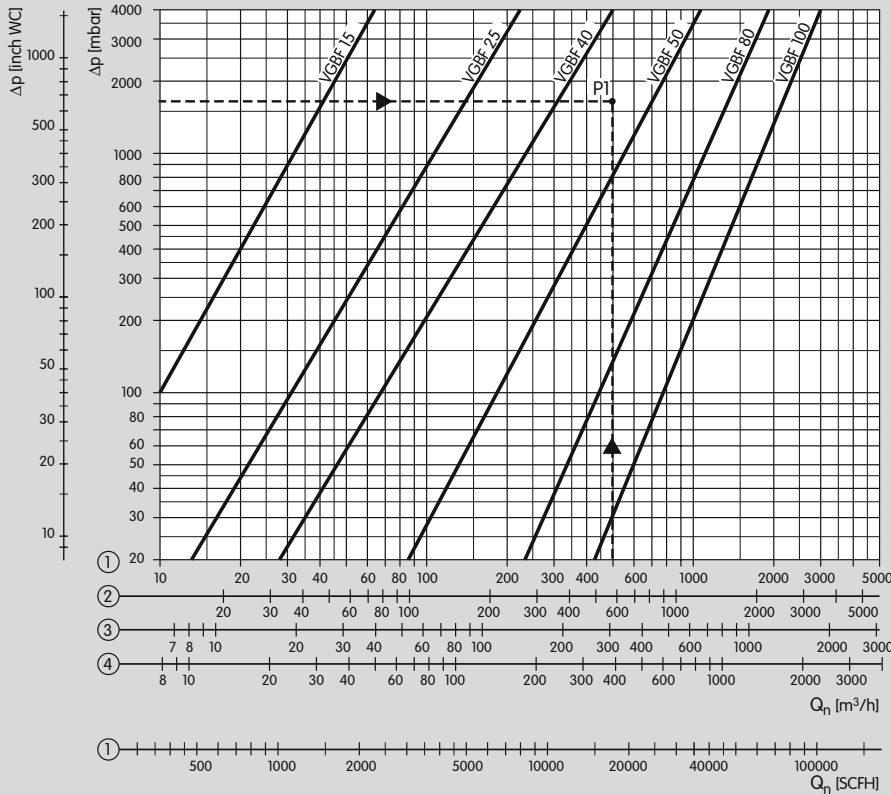

Gas type: natural gas,
 flow rate $Q = 500$ m^3/h ,
 inlet pressure $p_u = 2$ bar,
 outlet pressure $p_d = 300$ mbar,
 pressure loss $\Delta p = p_u - p_d = 1.7$ bar.

The result is intersection P1.
 The next largest nominal size is selected: VGBF 50..40.

At a pressure loss of $\Delta p = 1.7$ bar, the max. flow rate is $Q_{max.}$: 700 m^3/h , the min. flow rate is $Q_{min.}$ derived from $Q_{min.} = Q_{max.} \times 10\% = 70$ m^3/h .

- ① = natural gas ($\rho = 0.80$ kg/m^3)
- ② = town gas ($\rho = 0.64$ kg/m^3)
- ③ = LPG ($\rho = 2.01$ kg/m^3)
- ④ = air ($\rho = 1.29$ kg/m^3)

5 Selection

Type	T	N	R	A	F	05	10	40	-1	-2	-3	V
VGBF 15	●	●	●					●	●	●		
VGBF 25	●	●	●				●	●	●	●		
VGBF 40	●	●	●		●	●	●	●			●	○
VGBF 50	●			●	●	●	●	●			●	○
VGBF 65	●			●	●	●					●	○
VGBF 80	●			●	●	●	●	●			●	○
VGBF 100	●			●	●	●	●	●			●	○
VGBF 150					●	●	●				●	○

● = standard, ○ = available

Order example

VGBF 50F05-3

5.1 Type code

Code	Description
VGBF	Gas pressure regulator
15-150	Nominal size
T	T-product
N	NPT internal thread
R	Rp internal thread
A	ANSI flange
F	Flange to ISO 7005
05	$p_{U \max.}$ 500 mbar (7.5 psig)
10	$p_{U \max.}$ 1 bar (15 psig)
40	$p_{U \max.}$ 4 bar (60 psig)
-1	Screw plug at the inlet
-2*	Screw plug at the outlet*
-3	Screw plug at the inlet and outlet
V	Viton equipment (without approval)

* For T-products range only

6 Project planning information

6.1 Installation

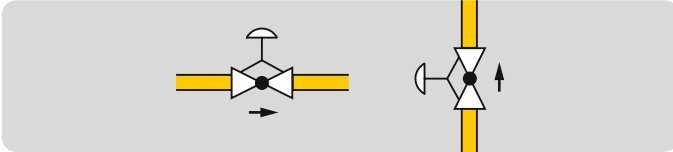

Installation position: any, not upside down. Recommended installation position as of nominal size DN 65: spring dome pointing vertically upwards.

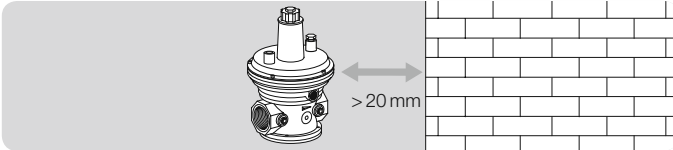

The gas pressure regulator VGBF must not be in contact with masonry. Minimum clearance 20 mm.

Do not store or install the unit in the open air.

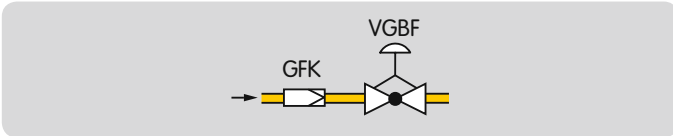

Sealing material and dirt, e.g. thread cuttings, must not be allowed to get into the regulator housing. Install a filter (GFK) upstream of every system.

6.2 Installation to EN 746-2

In accordance with EN 746-2, a safety shut-off valve upstream of the gas pressure regulator and a safety relief valve are required for gas pressure control systems.

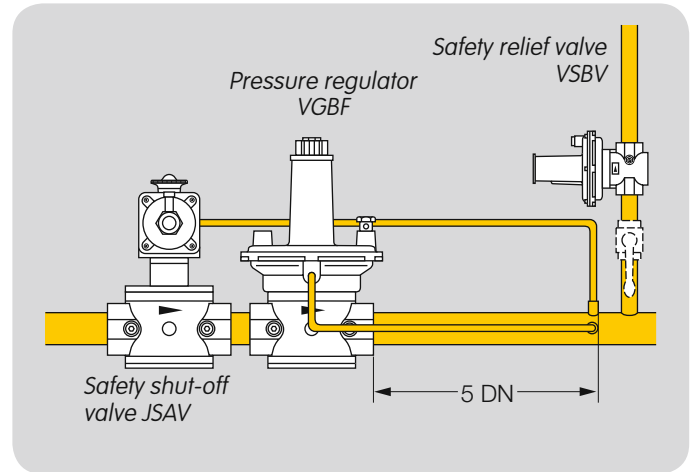

These valves are not required if the highest possible operating pressure upstream of the regulator cannot exceed the maximum allowable operating pressure of the downstream devices.

6.3 Installing the impulse line

Gas pressure regulator VGBF.F05 features an internal feedback function. On VGBF.F10 and VGBF.F40, the feedback function is performed via an external impulse line (5 x DN), see illustration at 6.2.

6.4 Installation to NFPA 86

NFPA 86-8.2.10 and NFPA 86-6.2.4

If the inlet pressure to a fuel pressure regulator exceeds the pressure rating of any component, overpressure protection shall be provided.

With reference to NFPA 86-6.2.4:

The gas pressure regulator requires a relief line on the spring dome, see illustration at 6.2.

7 Accessories

7.1 Damping valve

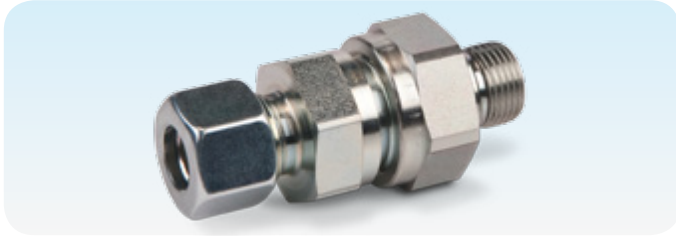

VGBF..10 and VGBF..40: damping valve for Rp $\frac{3}{8}$ impulse line.

VGBF..T: damping valve not available.

VGBF 15–25: not required.

VGBF 40–100..40: loosely enclosed.

Can be ordered on request for VGBF 40–150..10.

Order No. 75439215.

8 Technical data

Gas types: natural gas, town gas, LPG (gaseous) and biologically produced methane (max. 0.02 %-by-vol. H₂S), VGBF..V also for air. The medium must be dry in all temperature conditions and must not contain condensate.

Inlet pressure range: up to 500 mbar (7.25 psig), 1 bar (14.5 psig) and 4 bar (14.5 psig).

Outlet pressure ranges:

VGBF 15 – 50: 5 – 350 mbar (2 – 137 "WC),

VGBF 65, 150: 5 – 160 mbar (2 – 62 "WC),

VGBF 80, 100: 5 – 350 mbar (2 – 137 "WC).

VGBF..05: Class A.

VGBF..10, VGBF..40:

Accuracy Class: AC 10,

Lock-up pressure class: SG 30.

Ambient temperature:

standard: -15 to +60°C (5 to 140°F),

VGBF..V: 0 to +60°C (32 to 140°F).

Storage temperature:

standard: -15 to +40°C (5 to 104°F),

VGBF..V: 0 to +40°C (32 to 104°F).

Valve housing: aluminium,

valve seat and stem: aluminium.

Wetted diaphragms:

standard: Perbunan,

VGBF..V: Viton.

Valve disc:

standard: Perbunan,

VGBF..V: Viton.

Internal thread: Rp to ISO 7-1, NPT to ANSI/ASME.

Flanged connection:

PN 16 pursuant to ISO 7005, ANSI flange pursuant to ASA.

8.1 Dimensions

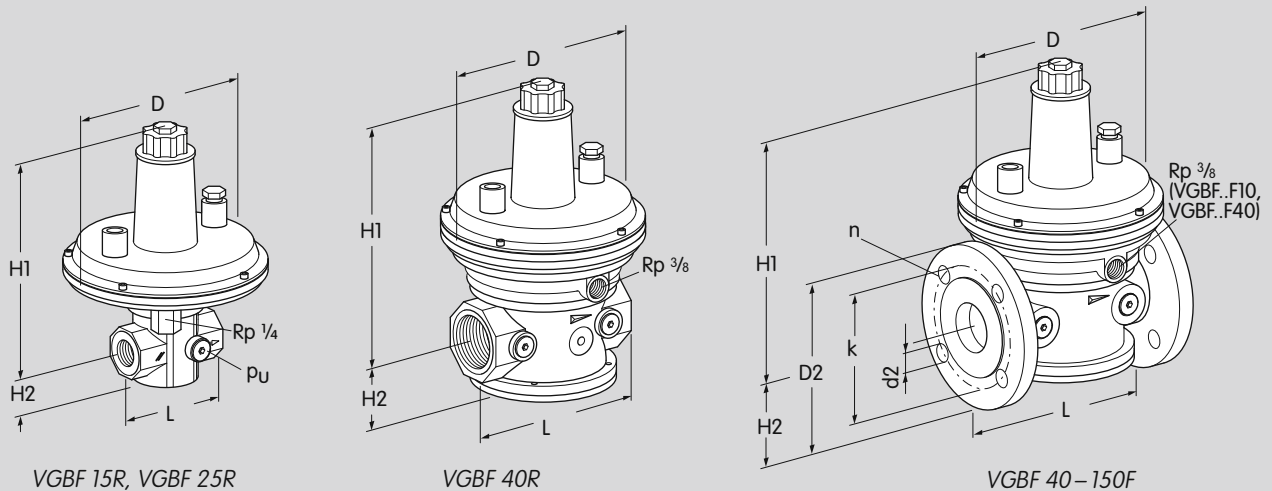

8.1.1 VGBF with Rp internal thread or with ISO flange

Type	Dimensions						p _u max. bar	Flange		Drilling		Weight kg
	DN	Connection	L mm	H1 mm	H2 mm	D mm		D2 mm	k mm	d2 mm	n No.	
VGBF 15R	15	Rp 1/2	70	151	24	132	4	–	–	–	–	0.9
VGBF 25R	25	Rp 1	90	250	33	190	1; 4	–	–	–	–	1.9
VGBF 40R	40	Rp 1 1/2	150	260	56	190	1; 4	–	–	–	–	2.9
VGBF 40F	40	40	200	260	75	190	0.5; 1; 4	150	110	18	4	4.8
VGBF 50F	50	50	230	316	83	240	0.5; 1; 4	165	125	18	4	7.7
VGBF 65F	65	65	290	412	89	260	0.5	185	145	18	4	12.0
VGBF 80F	80	80	310	446	100	310	0.5; 1; 4	200	160	18	8	16.1
VGBF 100F	100	100	350	501	115	396	0.5; 1; 4	229	180	18	8	26.0
VGBF 150F	150	150	480	573	150	520	0.5; 1	285	240	22	8	46.5

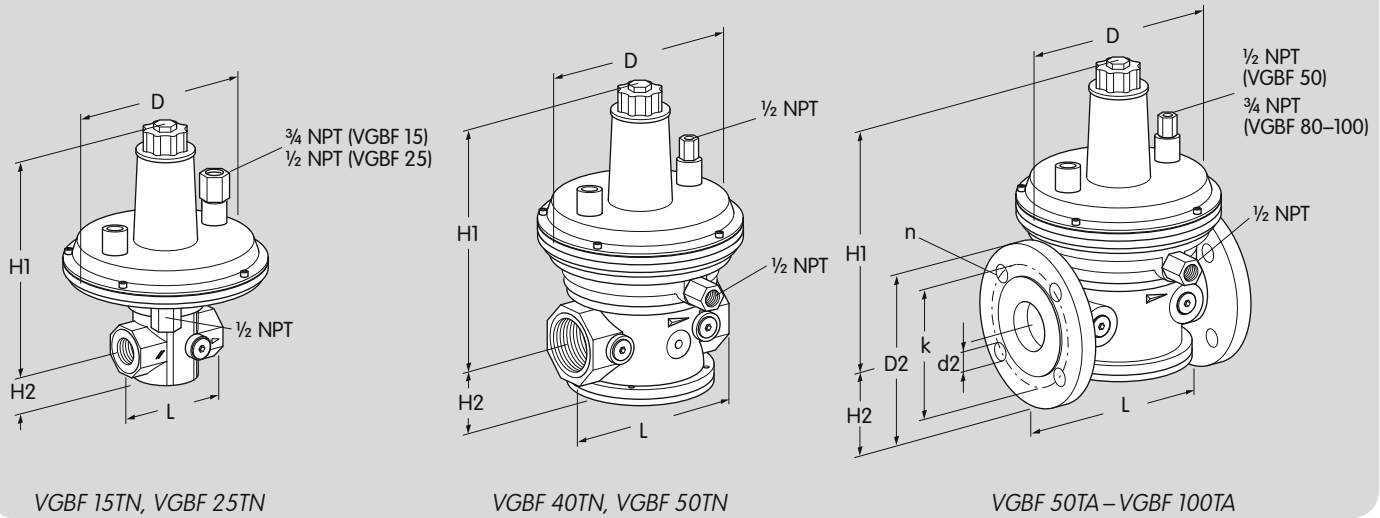

8.1.2 VGBF..T with NPT internal thread or with ANSI flange

Type			L	H1	H2	D	p _u max.	Flange		Drilling		Weight
	DN	Connection						D2	k	d2	n	
VGBF 15TN	15	1/2 NPT	2.76	5.91	0.94	5.20	1.5					2.0
VGBF 25TN	25	1 NPT	3.54	9.84	1.30	7.48	0.4; 1.5					4.2
VGBF 40TN	40	1 1/2 NPT	5.91	10.24	2.20	7.48	0.4; 1.5					6.4
VGBF 50TN	50	2 NPT	7.17	12.44	2.72	9.45	0.2; 0.4; 1.5					12.6
VGBF 50TA	50	2 ANSI	9.06	12.44	3.01	9.45	0.2; 0.4; 1.5	6.02	4.75	0.75	4	17.0
VGBF 80TA	80	3 ANSI	12.20	17.56	3.78	12.20	0.2; 0.4; 1.5	7.50	6.00	0.75	4	35.5
VGBF 100TA	100	4 ANSI	13.78	19.72	4.53	15.59	0.2; 0.4; 1.5	9.02	7.50	0.75	8	57.3

8.2 Spring table

Outlet pressure range		Marking	Order No.						
mbar	"WC		VGBF 15	VGBF 25 VGBF 40	VGBF 50	VGBF 65	VGBF 80	VGBF 100	VGBF 150
5–12.5	2–5	–	75421911	75421961	75422031	75426160	75426230	75426310	75426450
10–30*	4–12	red	75421921	75421971	75422041	75426170	75426240	75426320	75426460
25–45	10–17.5	yellow	75421931	75421980	75422051	75426180	75426250	75426330	75426470
40–60	16–23	green	75421941	75421990	75422061	75426190	75426260	75426340	75426480
55–75	21–29	blue	75421951	75422000	75422071	75426200	75426270	75426350	75426490
70–90	27–35	black	75442046	75422010	75422081	75426210	75426280	75426360	75426500
85–105	33–41	white	75442047	75422020	75422091	75426220	75426290	75426370	75426510
100–160**	39–62	black/red	75442048	75438978	75438981	75446329	75438984	75438987	75438990
150–230	58.5–90	black/yellow	75442049	75438979	75438982	–	75438985	75438988	–
220–350	86–136.5	black/green	75442050	75438980	75438983***	–	75438986	75438989	–

Dispatch complete with label for changed outlet pressure.

* Standard spring.

** T-products range standard spring.

*** Spring set comprising two springs.

9 Maintenance cycles

At least once a year, at least twice a year in the case of biologically produced methane.

Feedback

Finally, we are offering you the opportunity to assess this "Technical Information (TI)" and to give us your opinion, so that we can improve our documents further and suit them to your needs.

Clarity

Found information quickly
Searched for a long time
Didn't find information
What is missing?
No answer

Comprehension

Coherent
Too complicated
No answer

Scope

Too little
Sufficient
Too wide
No answer



Use

To get to know the product
To choose a product
Planning
To look for information

Navigation

I can find my way around
I got "lost"
No answer

My scope of functions

Technical department
Sales
No answer

Remarks

(Adobe Reader 7 or higher required)
www.adobe.com

Contact

Elster GmbH
Postfach 2809 · 49018 Osnabrück
Strothweg 1 · 49504 Lotte (Büren)
Germany
T +49 541 1214-0
F +49 541 1214-370
info@kromschroeder.com
www.kromschroeder.com
www.elster.com

The current addresses of our international agents are available on the Internet:
www.kromschroeder.de/index.php?id=718&L=1

We reserve the right to make technical modifications in the interests of progress.
Copyright © 2013 Elster Group
All rights reserved.

