

Open / Closed



SKP15...

Open / Closed
with constant pressure
governor



SKP25...

Open / Closed
with differential pressure
governor



SKP55...

Open / Closed
with ratio pressure governor



SKP75...

Actuators for gas valves

SKPx5...

- Open / closed safety shutoff function conforming to EN 161 in combination with valves supplied by Siemens
- Damped opening (rapid closing)
- Very low power consumption
- Suitable for use with gases of gas families I...III
- Optionally with / without end switch (factory-set)
- Plug-in connection facility
- Electrical indication of operation
- Valve stroke indication
- Supplementary Data Sheets on valves (refer to «Use»)
- Models for USA on request

The SKPx5 and this Data Sheet are intended for use by OEMs which integrate the actuators in their products.

Use

Modular concept

Actuators are designed for use with the following types of valves:

Type of valve	Medium	Data Sheet
VGG	Natural gas	N7636
VGf	Gases of gas families I...III	
VGD2	Natural gas	N7631
VGD4	Gases of gas families I...III	
VRF	Biogas (with SKP15, other actuators on request)	N7633
VLF	Hot air	N7637

Actuators SKPx5 in general

The combination of actuator and valve provides the following functions:

- Safety shutoff valve (SKP15)
- Safety shutoff valve with gas pressure governor (SKP25, SKP55, SKP75)

The electrohydraulic actuators together with the valves are designed for use with gases of gas families I...III and air. They are used primarily on gas-fired combustion plant. The actuators open slowly and close rapidly. The actuator can be supplied with end switch (for indicating the fully closed position). For information about valve sizing, refer to the «Valve sizing chart» in the Data Sheet of the relevant valve.

If the actuators are used with gases other than those of gas families I...III, **Siemens AG** assumes no responsibility for the actuator's durability and life expectancy.

All types of actuators can be combined with any of these valves.

SKP15

The electrohydraulic operated gas fittings SKP15 together with VGx valves works exclusively as a safety shutoff valve (Open / Closed). They are used primarily on gas-fired combustion plant. The actuators open slowly and close rapidly.

A valve stroke indication at actuator can only be delivered with end switch.

SKP25

The SKP25 operates with a gas pressure governor and controls the gas pressure according to the setpoint preselected with the setpoint spring or air pressure signal.

Its field of use is primarily forced draft gas burners

- with mechanical air / fuel ratio control (SKP25.0)
- with electronic air / fuel ratio control (SKP25.0)
- with 2-stage setpoint changeover (SKP25.2)
- with proportionate governor (SKP25.3)
- with high pressure governor (SKP25.4)
- with zero pressure governor (SKP25.6)
- with constant pressure control, but with electric pressure setpoint adjustment (SKP25.0 with AGA30.7 and SAS)

SKP25.0 with AGA30.7 and SAS

The SKP25.0 with AGA30.7 and SAS solution enables motorized pressure setpoint adjustment

- for motorized setting or correction of the setpoint
- for atmospheric and comparable burner operating conditions, typical output modulation multistage or shifting < 1 : 5
- not for gas-air ratio combined systems (e.g. class C in accordance with EN 12067-2)
- SKP25.0 (with AGA30.7 and SAS) must not be used in applications that require mechanical operating conditions higher than class 3M1 (EN 60721-3-3). Vibrations are not permitted. Corrective measures must be implemented on the plant in individual cases.

SKP55

The SKP55 operates with a differential pressure governor and controls a differential gas pressure according to a differential air pressure. The ratio of the differential pressures is 1-to-1 and constant across the entire air range.

Its field of use is predominantly

- combustion plant with combined heat recovery systems
- plant where pressure conditions in the burner and combustion chamber do not change in proportion to load changes
- burners with adjustable air / fuel mixing devices in the burner head
- plant with negative pressure levels on the gas or air side

SKP75

The SKP75 operates as a ratio pressure governor and provides control of the gas pressure depending on the pressure of the combustion air, ensuring that the adjustable gas / air ratio remains constant across the entire load range.

Its field of use is primarily modulating forced draft gas burners.

Warning notes



For additional safety notes, refer inside of Data Sheet!

To prevent injury to persons, damage to property or the environment, the following warning notes must be observed!

- Do not open, interfere with or modify the actuators!
- Any opening of the actuator, replacement of parts or modifications to the original product is the user's responsibility and carried out at his own risk
- All activities (mounting, installation and service work, etc.) must be performed by qualified staff
- When used in connection with gas, the actuators constitute part of the safety equipment
- Not suitable gases or gas components causes loss of the safety shutoff function
- Check to ensure that the impulse pipes are correctly fitted and tight (SKP25, SKP55, SKP75)
- Fall or shock can adversely affect the safety functions. Such actuators must not be put into operation, even if they do not exhibit any damage
- Each time work has been carried out (mounting, installation, service work, etc.), check to ensure that wiring is in an orderly state and make the safety checks as described in «Commissioning notes»
- If mains voltage is fed to the end switch (CPI), protective earth must be connected to the actuator via the same plug (AGA65)
- Use of connectors conforming to DIN EN 175301-803-A is mandatory
- The connectors used must feature cable strain relief
- Solar radiation or formation of ice are not permitted!

SKP25.2

When using SKP25.2, relevant interference suppression measures (EMC) must be implemented on the plant side.

The magnet can reach high temperatures if activated for longer periods of time.

The SKPx5.xx1xx are supplied with the end switch factory-set.

Design of the gas train

If the available gas pressure exceeds the maximum permissible operating pressure of the valve (VGx / VRx) / actuator (refer to the Data Sheet of the relevant valve), it must be lowered by an upstream pressure controller. The pressure switch for lack of gas must always be fitted upstream of the valve when used in combination with the actuator.

SKP25, SKP55, SKP75

The impulse pipes must be installed such that the differential pressure can be acquired with no disturbance (unfavorable flow conditions). Pressure test points must not protrude and be flush with the inside diameter of the pipe or duct wall. The impulse lines to the governor should be as short as possible, enabling the governor to respond quickly should sudden load changes occur. The inside diameter of the impulse pipes must be a minimum of 6 mm.

In connection with the SKP25, the 1/4" nozzles on the outlet side of the VGx valves can be used as pressure test points (prerequisite: gas control pressure setpoint >1 kPa).

SKP75

- Installation of impulse pipes:
In the case of unsafe combustion chamber pressure pipes (e.g. resulting from potential leaks). The setting must also be checked during operation without having the combustion chamber pipe connected, especially with respect to maximum burner capacity. The impulse pipes must be fitted such that the differential pressure can be acquired with no disturbance. With gas / air ratios >3, the impulse pipes for the combustion air and the combustion chamber pressure must have an inside diameter of at least 8 mm. The impulse pipe for the combustion chamber pressure must be fitted such that the gases will cool down in the vicinity of the impulse pipe and condensing gases cannot enter the governor but will return to the combustion chamber.



Warning!

If there is a risk of the impulse pipes being exposed to heat, all impulse pipes must be made from suitable metal material

Recommendations:

- The gas pressure should be acquired at a distance of 5 times the nominal pipe size downstream from the valve
- that the lateral pressure test points on the valve should not be used for picking up the pressure.
- Considering the combustion chamber pressure:
If the resistance value of the combustion chamber / heat exchanger / stack system is constant, the combustion chamber pressure changes in proportion to the gas and combustion air pressure as the burner's output changes. In that case, the combustion chamber pressure need not be fed to the SKP75 as a disturbance variable. However, if the combustion chamber pressure does not change to the same extent as the gas and air pressure – as this is the case in plants with flue gas fan or modulating flue gas damper – the combustion chamber pressure must be fed to the SKP75 as a disturbance variable, enabling the governor to counteract.
- If the SKPx5 are operated until the end of their lifecycle, the decreasing drive power can result in a lower gas quantity or gas pressure on the outlet of the gas fitting. If the use requires a minimum pressure behind the gas fitting, the minimum pressure must be monitored

Mounting notes

- Ensure that the relevant national safety regulations are complied with
- The quadratic arrangement of the fixing holes allows the actuator to be fitted in 4 different positions on the VGx valve, each step being 90° (depending on the type of VGx valve)
- The actuator can be mounted or replaced while the system is under pressure; sealing material is not required
- SKP25 / SKP55 / SKP75:
SKPx5 with pressure control function have a vent opening on the pressure governor. Measures must be taken in the application to prevent the vent opening from being blocked



Warning!

Condensation, formation of ice and ingress of water are not permitted. If this is not observed, there is a risk of loss of safety functions and a risk of electric shock.

- Follow the Mounting Instructions included with the actuators:

Type reference	Mounting instruction
SKP15	M7643 (74 319 0420 0)
SKP25	M7643 (A5W00000658)
SKP25 with AGA30.7 and SAS	M7643.4 (74 319 0552 0)
SKP55	M7643 (74 319 0420 0)
SKP75	M7643 (74 319 0420 0)
AGA66-IP65-Kit for SKPx5 / VGx	M7643.2 (74 319 0421 0)

Sealing / tightness

- Check the tightness when all components are connected

Actuators in general

- Electrical commissioning may only be performed when the actuator is fitted to the valve; otherwise, the actuator can be damaged
- Power is supplied and connection of the end switch is made directly via a connecting cable (conforming to DIN EN 175301-803-A)
- The end switch is factory-set
- The pump's stem must not be pulled out using the over stroke element since that part could become loose

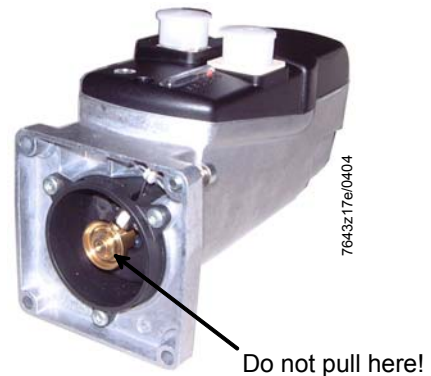

Installation and commissioning notes

Functioning principle of 1-stage actuator SKP15 with safety shutoff feature

When power is applied, the pump will be activated and the control valve closed. Oil is now pumped from the chamber below the piston to the stroke chamber above the piston. The oil pressure causes the piston to move downward, thereby opening the valve – against the pressure of the closing spring. The pump remains energized until the closing command is given. When power is removed, or in the event of a power failure, the pump will be deactivated and the control valve opened so that the closing spring pushes the piston back. The return flow system is sized such that the counter-stroke required for reaching the fully closed position is completed within about 0.6 seconds.

SKP15 complete with valve

(Schematic drawing)

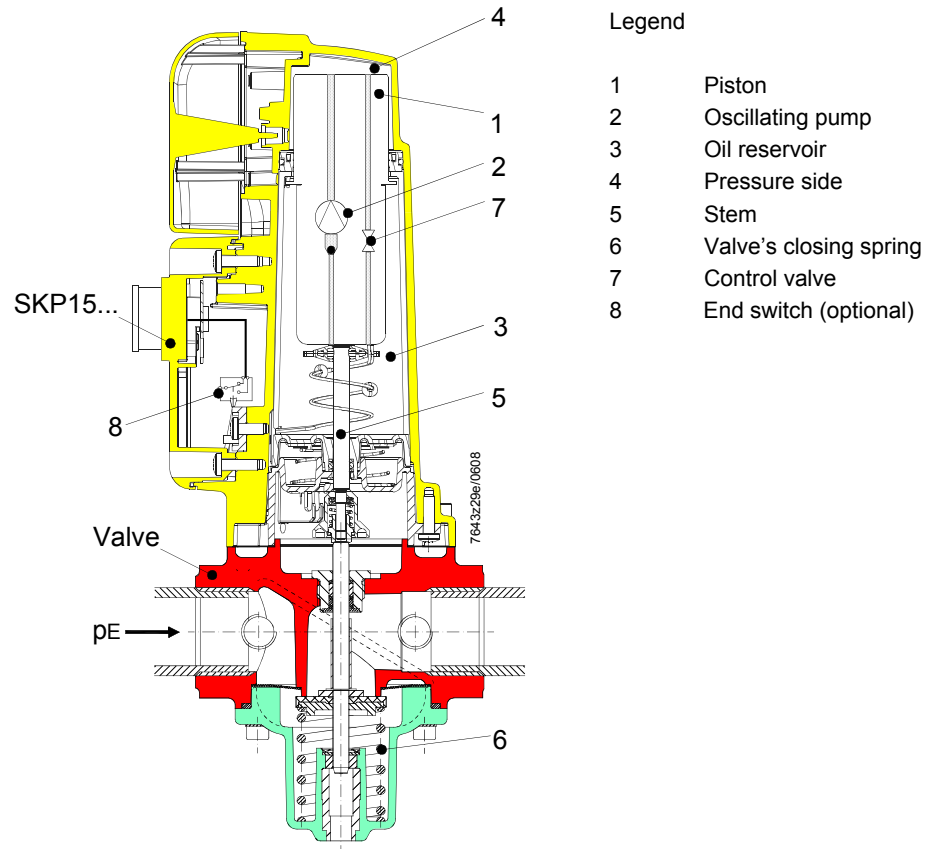

SKP25, SKP55 and SKP75

The functioning principle (safety shutoff feature) is identical to that of the SKP15, but with the help of their pneumatic governor, the SKP25, SKP55 and SKP75 also control a bypass valve in the hydraulic circuit and thus the valve's opening position.

SKP25 complete with valve

(Schematic drawing)

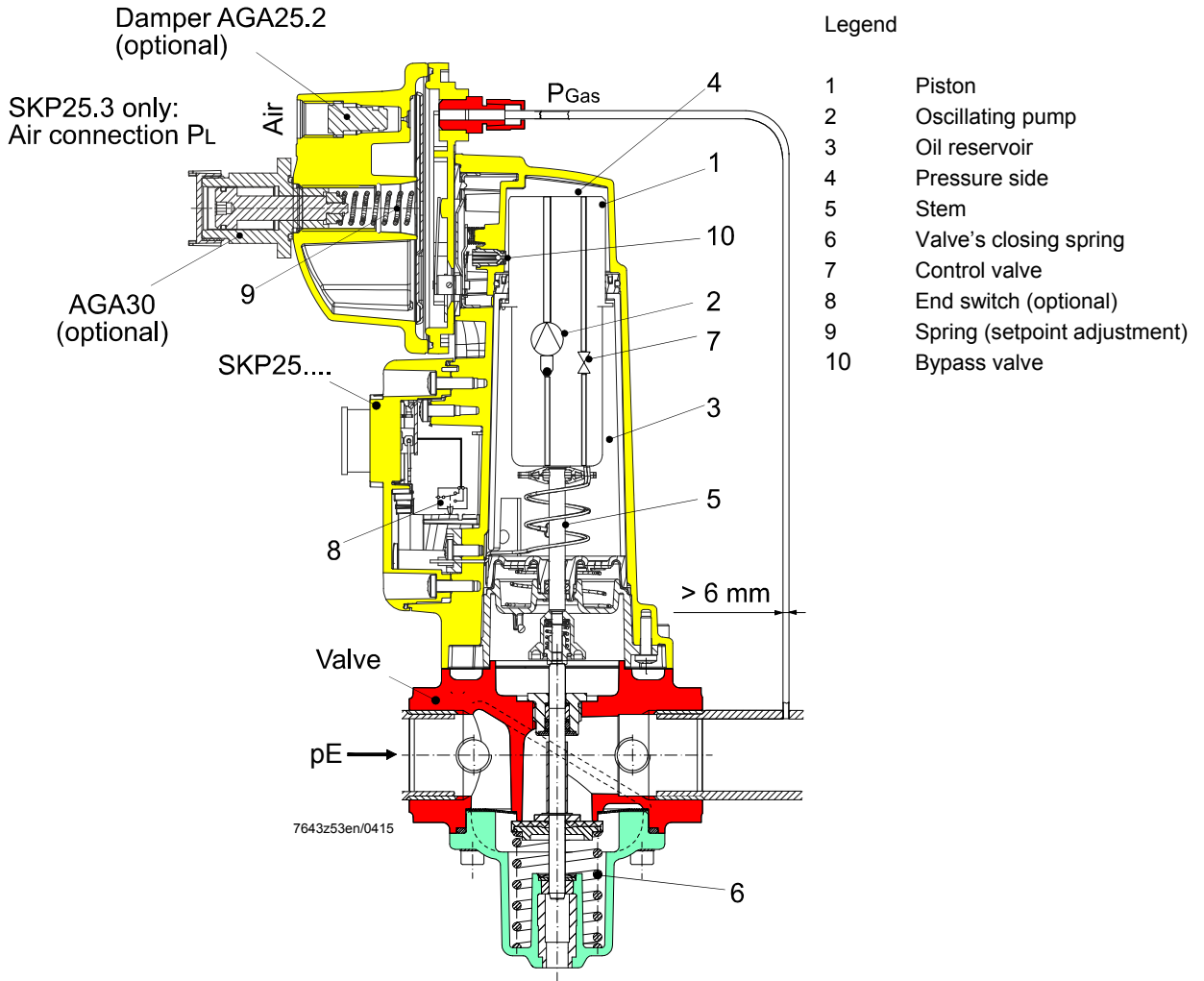

SKP25

Setpoint adjustment «P_{Gas}» is made manually by turning the setting screw, which acts on the setpoint spring (for setpoint springs, refer to «Accessories»).

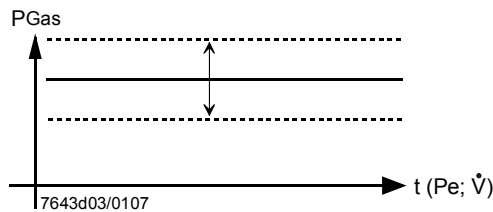

Legend

- Pe Inlet pressure
- \dot{V} Volumetric flow
- P_{Gas} 0...2,2 kPa (with built-in AGA29 standard spring), presetting 1,5 kPa

SKP25.3

The SKP25.3 operates based on the proportionate pressure principle «PL» : «PG» = 1:1.

By feeding fan pressure «PL» to the air connection, gas pressure «PGas» follows in a fixed 1-to-1 ratio.

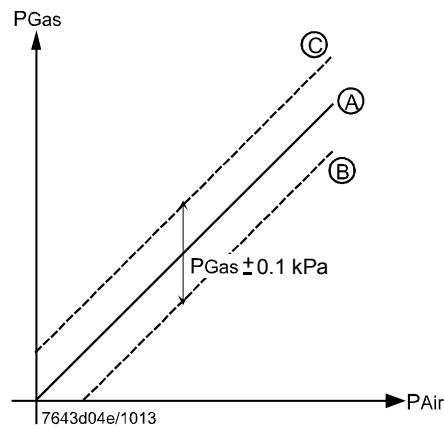

- (A) Gas / air ratio for stoichiometric combustion
- (B) / (C) The governor permits one parallel displacement in both directions: «gas pressure lowering» (B) and «gas pressure elevation» (C)



Note!
Fit cap again before measuring the combustion value and after the setting is made.

SKP25.6

SKP25.6 zero pressure governor works like SKP25.3, but enabled a larger parallel displacement towards gas pressure lowering.

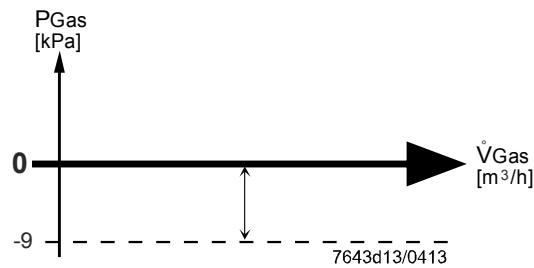

- Legend
- \dot{V} Volumetric flow
 - PGas Offset spring 0...0,9 kPa
 - 0** **Atmospheric pressure**

Installation and commissioning notes (continued)

SKP25 with AGA30.7 and SAS

The SKP25.0 (with AGA30.7 and SAS) operates like the SKP25 constant pressure governor, but features electromotoric adjustment of the setpoint spring.

It is used primarily in

- atmospheric or comparable burners in modulating or multistage operation
- individual burners or groups of burners on industrial furnaces (gas pressure correction and disturbance variable compensation)
- not approved for gas-air ratio combined solutions (e.g. class C in accordance with EN 12067-2)

SKP25.0 complete with valve

(simplified sectional view)

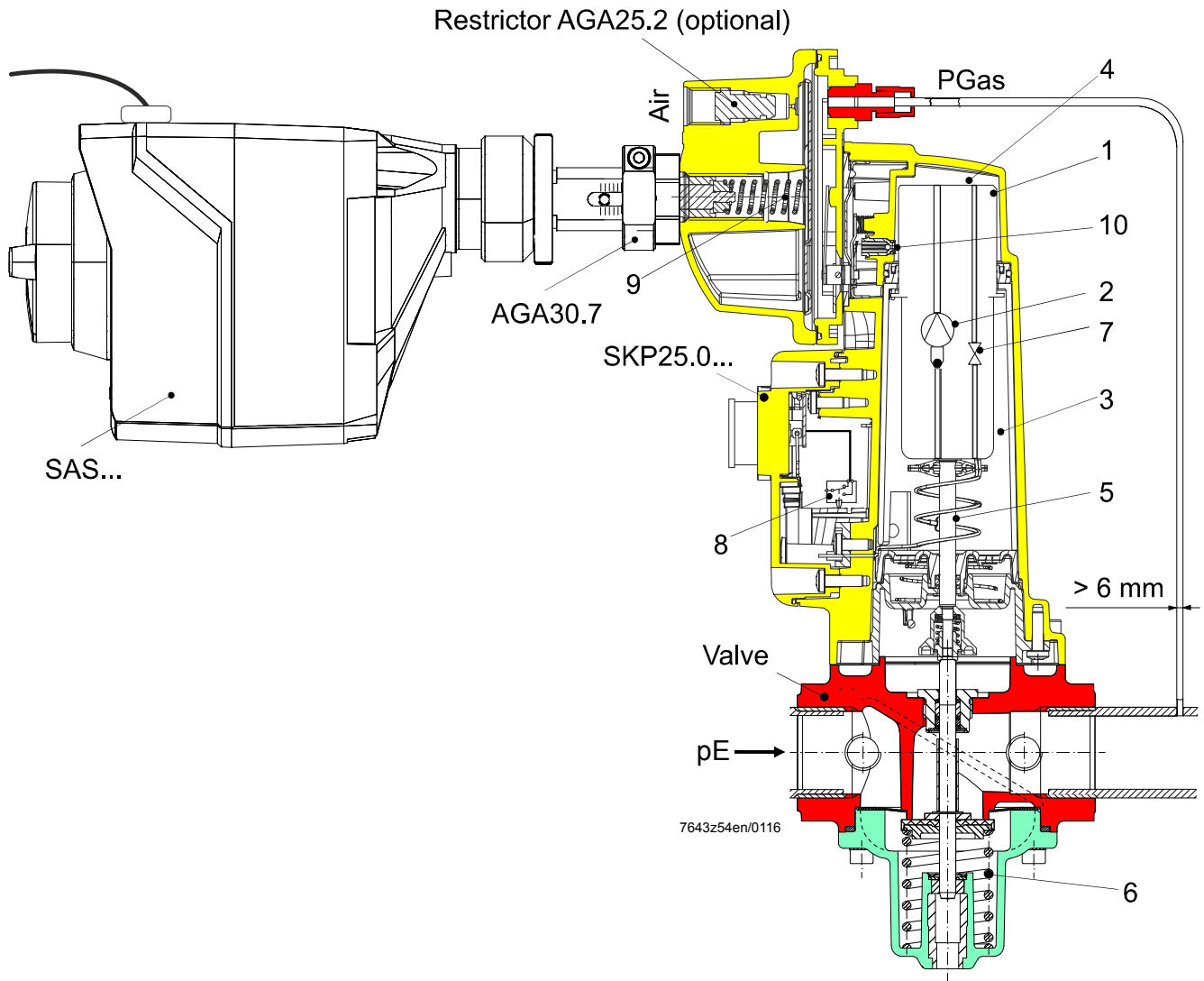

Key

- | | | | |
|---|------------------|----|-------------------------|
| 1 | Piston | 6 | Closing spring of valve |
| 2 | Oscillating pump | 7 | Control valve |
| 3 | Oil reservoir | 8 | End switch (optional) |
| 4 | Pressure side | 9 | Position indication |
| 5 | Stem | 10 | Bypass valve |

Setting example::

The low-fire pressure value (offset) is adjusted by screwing in the AGA30.7 on SKP25.0. The maximum high-fire limitation (maximum pressure (PGmax)) is set with the stem of the SAS extended via the lock nut on AGA30.7.

The desired pressure ranges (up to 32 kPa) are determined by use of the setpoint springs (AGA22, AGA23, 7421500490).



Note!
See Mounting Instructions A5W00000658 (M7643).

Functioning principle of the gas pressure governor with SAS motorized setpoint adjuster:

On the gas outlet side, the gas pressure governor maintains the pressure at the required setpoint. An electric signal on the SAS changes the specified setpoint (PR) proportionally. If the SAS motor stops, the outlet pressure remains constant.

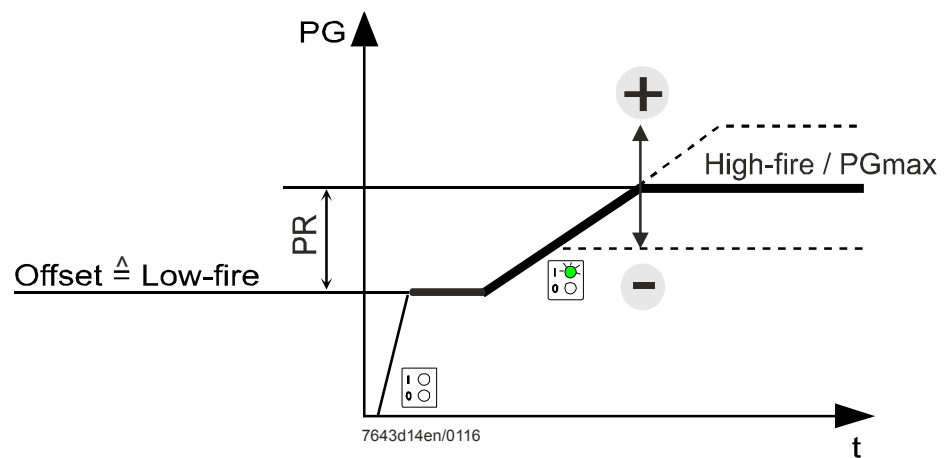

SAS

Different SAS motors can be used depending on the required function (e.g. electric control signal), see Data Sheet N4581.

SKP25.2

The SKP25.2 features 2-stage setpoint changeover for 2-stage gas burners.

Assembly of **SKP25.2**
complete with valve

(Schematic drawing)

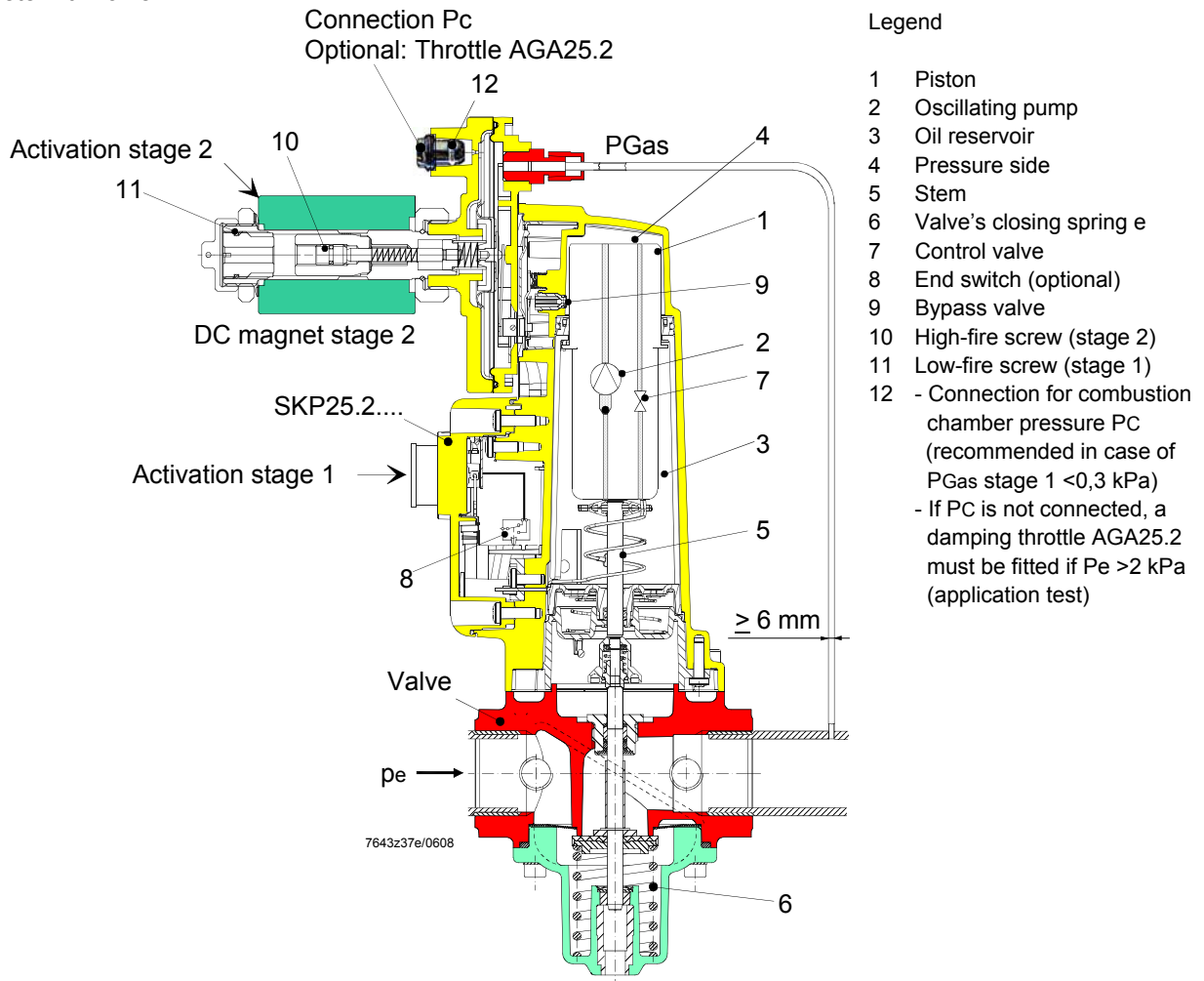

Setpoint adjustment «P_{Gas}» is made manually by turning the setting screws (10 and 11), which act on the setpoint spring.

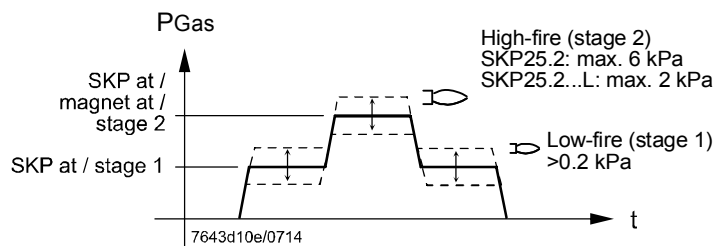

Setting example:

1. Set the low-fire load (stage 1):
Set the low-fire screw (11) to the required pressure value (∪ +P_{Gas}).
2. Set the high-fire (stage 2):
Activate stage 2 and set the high-fire screw (10) to the required pressure value (∪ +P_{Gas}).
3. After setting the high-fire, the low-fire load need be readjusted. Every high-fire setting / readjustment changes the low-fire setting!

Note!
Refer to Mounting Instructions M7643.4 (74 319 0552 0)
Default settings: Low-fire: 1,2 kPa / high-fire: 5,5 kPa

SKP25.4

The SKP25.4 is suited for the control of higher pressures.
Standard spring 0...150 kPa.

SKP25.4 complete with valve

(Schematic drawing)

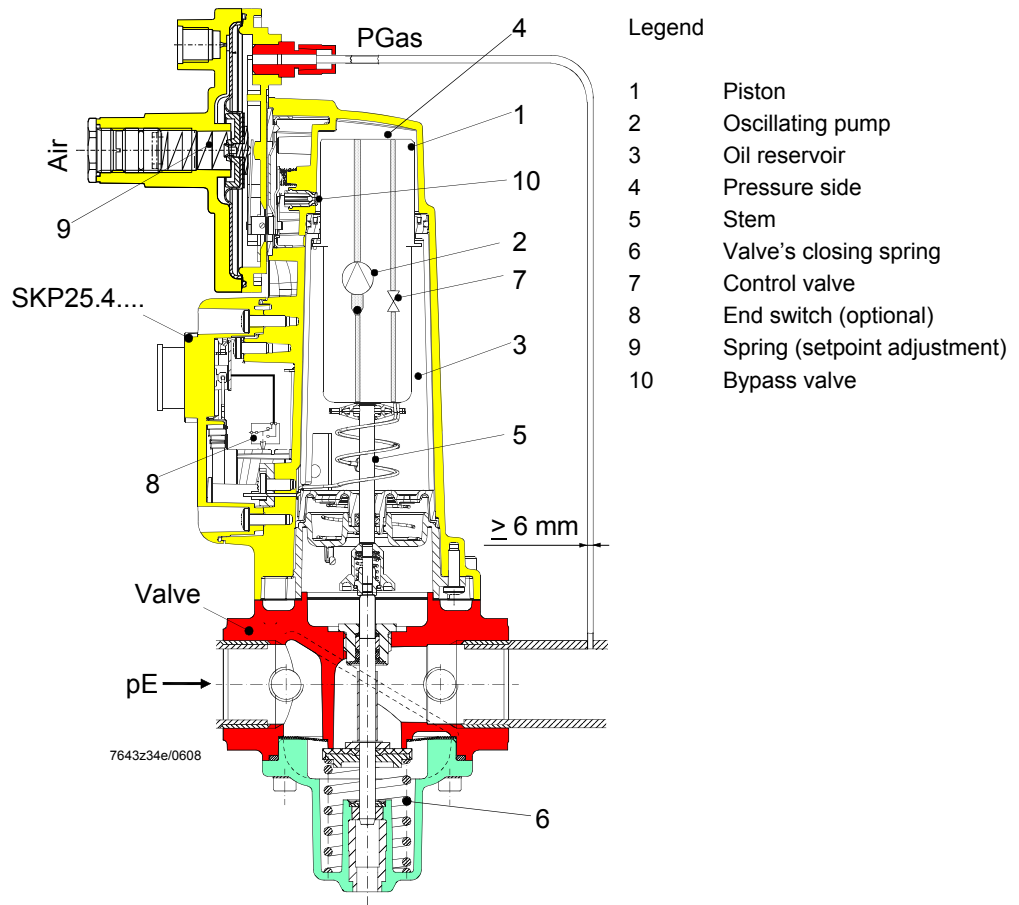

Setpoint adjustment «PGas» is made manually by turning the setting screw, which acts on the setpoint spring (for setpoint springs, also refer to «Accessories»).

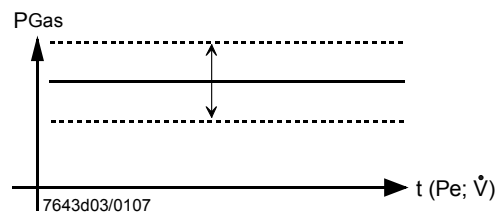

Legend

- | | |
|-----------|--|
| Pe | Inlet pressure |
| \dot{V} | Volumetric flow |
| PGas | 0...150 kPa
(with built-in standard
spring AGA23), presetting
120 kPa |

SKP55

The SKP55 operates with a differential pressure governor and a fixed differential pressure ratio of 1-to-1.

SKP55 complete with valve

(Schematic drawing)

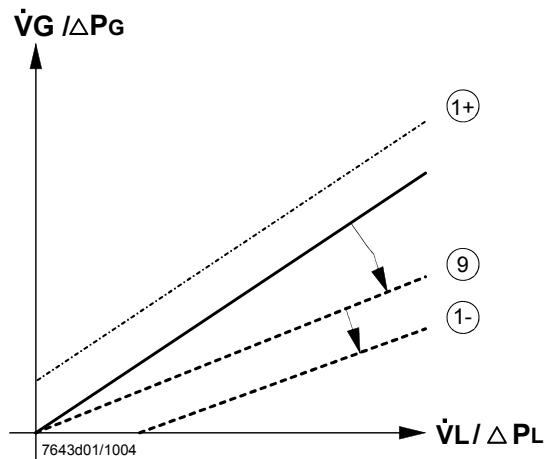
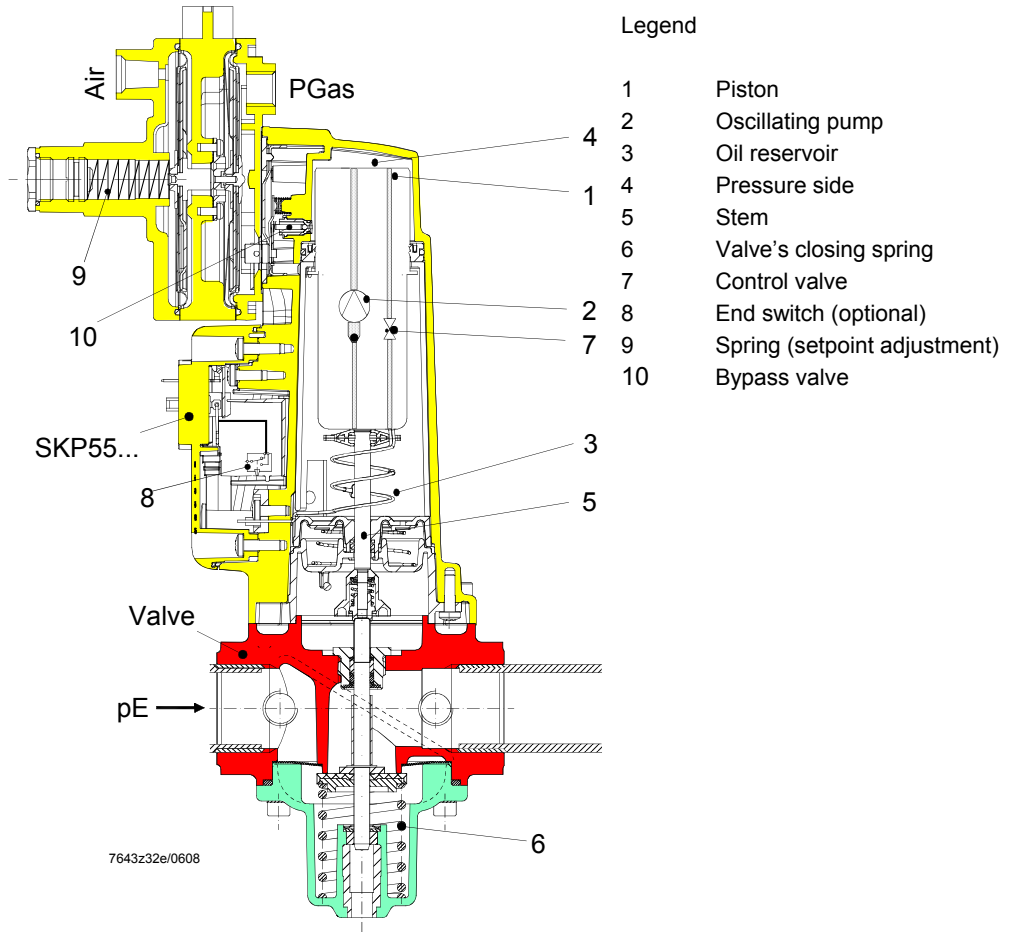

Example:
Adjusted gas / air ratio for burner operation with gas pressure elevation (1+). The percentage of gas pressure lowering is constant across the entire load range. Gas / air ratio adjustment with the adjustable orifice on the gas side (see position 9).

Legend

- \dot{V}_L Volumetric air flow
- \dot{V}_G Volumetric gas flow

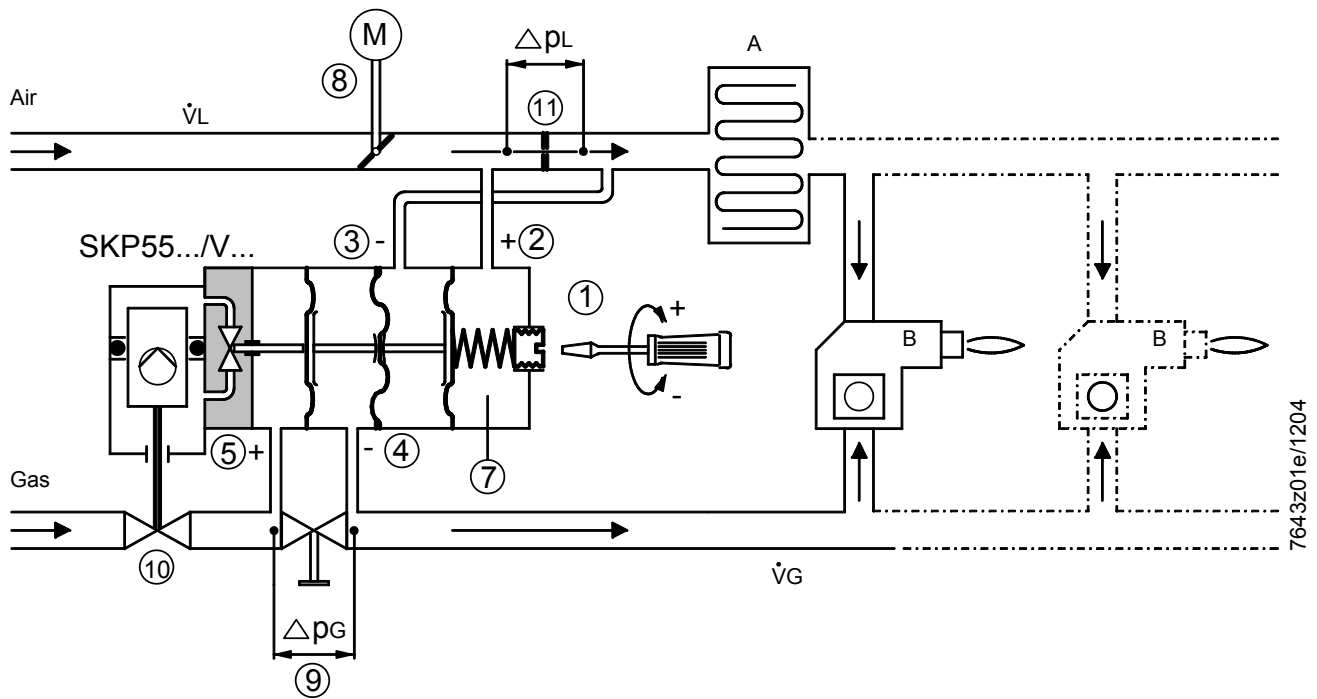

Safety notes:

 Arrangement air damper ⑧ / orifice ⑪ must always be located as shown, which means that orifice ⑪ must be installed downstream from the air damper ⑧.

Arrangement valve ⑩ (VGx) / orifice ⑨ must always be located as shown, which means that orifice ⑨ must be installed downstream from the valve ⑩.

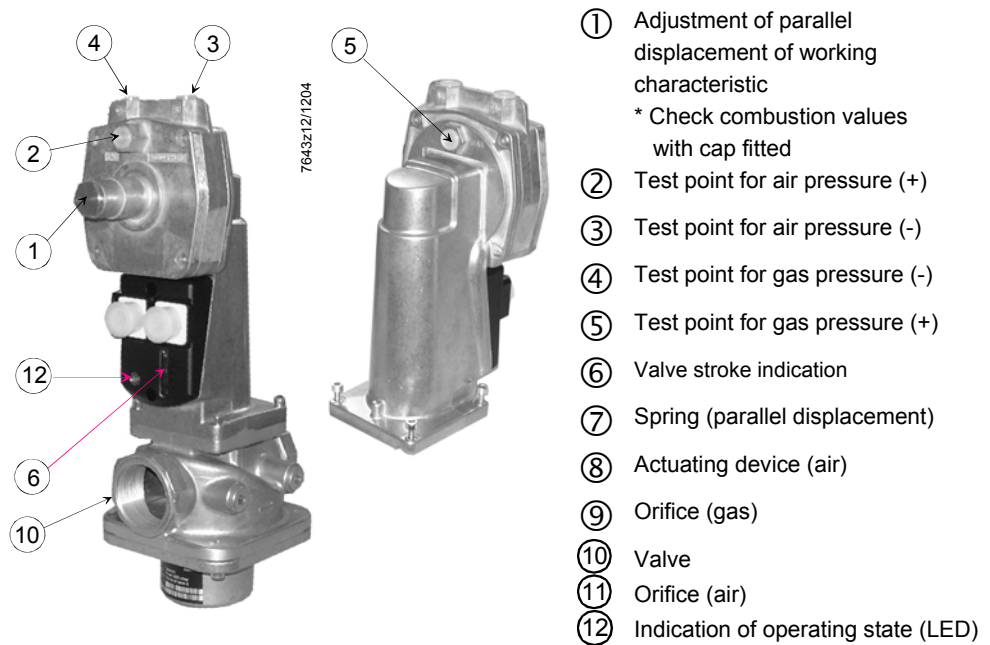

Legend

- ΔpG Differential pressure across orifice on the gas side
- ΔpL Differential pressure across orifice on the air side
- A Air heating coil (recuperator)
- B Burner
- M Actuator

SKP55

Adjustment of governor on modulating burners prior to startup:

- Setting screw ① on the SKP55 should be set to a gas / air ratio curve which passes through the neutral point. The SKP55 is supplied with that factory setting. Adjustment in the field can be made as follows:

Note:

Fit cap again before measuring the combustion value and after the setting is made.



Turn setting screw ① in counterclockwise direction until spring ⑦ is completely loose. Shut off the gas supply upstream of the SKP55. Switch on the SKP55. Turn setting screw ① in clockwise direction until valve opens

- Bring the adjustable orifice ⑨ to the precalculated value. That value with the same pressure differential on the air and gas side must lead to practically stoichiometric combustion
- Start the burner and run it to about 90 % of the high-fire
- Measure the combustion quality and make adjustments of the flow rate with the adjustable orifice ⑨ until optimum measured values are reached (fine adjustment)
- Return to low-fire operation. Check the combustion and readjust if necessary the position of the working characteristic with the setting screw ① on the SKP55 until optimum measured values are reached. Clockwise rotation → more gas. Counterclockwise rotation → less gas, that is, parallel displacement of the working characteristic towards gas pressure elevation or gas pressure lowering
- Limit the air damper ⑧ for low-fire operation
- If a significant parallel displacement of the working characteristic was required, the setting must be checked again at 90 % of the high-fire and then readjusted, if required
- Run the burner to the predefined high-fire with the help of the air damper ⑧ and limit the actuator position for that load
- Check the flue gas values at a few positions of the load range. Make readjustments in the high-fire range with the adjustable orifice ⑨, and in the low-fire range with setting screw ① on the governor of the SKP55.

SKP75



The SKP75 operates with a ratio pressure governor and an adjustable gas / air ratio.

SKP75 complete with valve

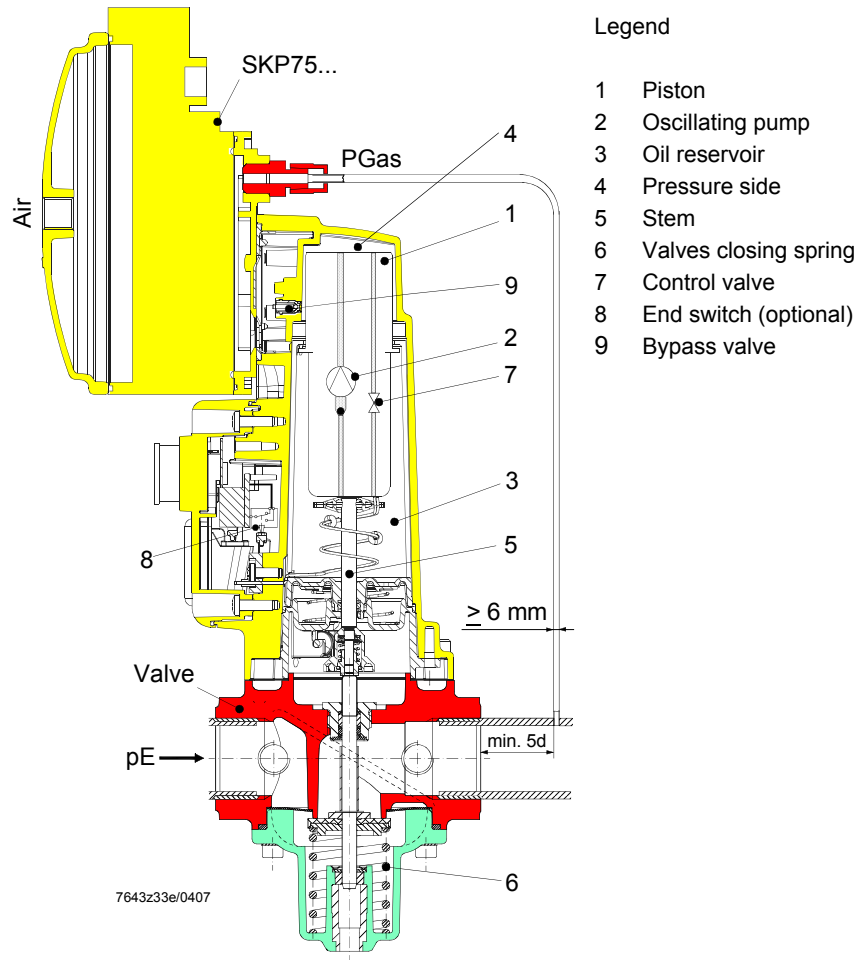
(Schematic drawing)



Adjustment of governor on modulating burners

- Use setting screw ① / «PGAS» / «PAIR» to set the gas / air ratio to the required value (coarse setting) and the scale  with setting screw ② to zero (refer to Fig. 7643z03)
- Start the burner and run it to about 90 % of the high-fire
- Measure the CO₂ or O₂ content of the flue gases and optimize the adjustment with setting screw ① / «PGAS» / «PAIR»  (refer to Fig. 7643z03)
- Return to low-fire operation, check the CO₂ or O₂ content of the flue gases. If necessary, readjust position of the working characteristic with setting screw ② /  until optimum measured values are attained
- Limit the air damper position for low-fire operation



Meaning of setting screw markings:

- + More gas
- Less gas

If a significant parallel displacement of the working characteristic was required to obtain optimum CO₂ or O₂ values in low-fire operation, the adjustment of the pressure ratio at high-fire or 90 % of the high-fire must be checked again and readjusted, if required.

- Run the burner to the required output and limit the high-fire air damper position
- Check the flue gas values at various positions of the load range

If readjustments are required:

- Use setting screw ① / «PGAS» / «PAIR»  in the high-fire range
- Use setting screw ② /  to make parallel displacements of the characteristic in the flow-fire range

If the gas / air pressure ratio lies outside the setting range, an orifice in the gas or air flow can be used to adjust the pressure at the test points on the burner side.

Prerequisite is that there is a sufficient gas or air pressure reserve on the inlet side.

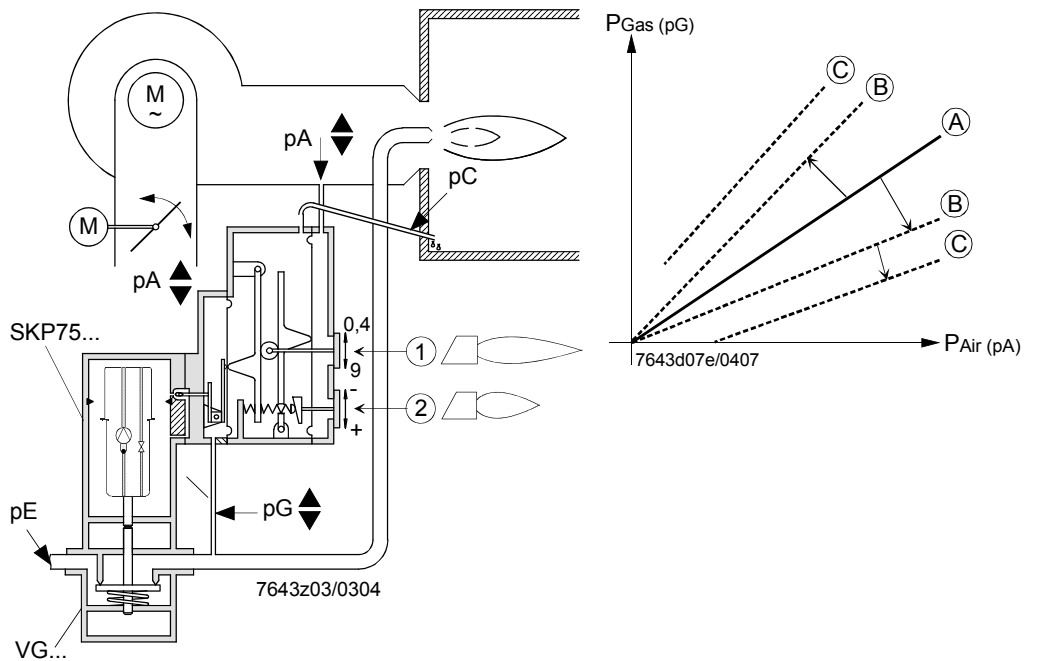

- ① Setting and display of the gas / air ratio
- ② Setting and display of parallel displacement of the working characteristic
- ③ Test point for combustion chamber pressure
- ④ Test point for air pressure
- ⑤ Test point for gas pressure
- ⑥ Valve stroke indication
- ⑦ Operation indicator (LED)
- ⑧ Valve

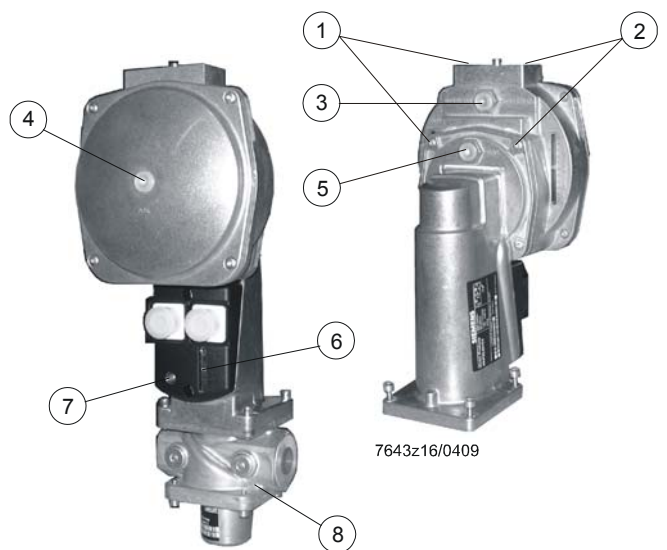

Installation and commissioning notes (cont'd)

Function

If the air pressure (fan pressure) exceeds the maximum value of

- 3 kPa with a $P_{\text{Gas}} / P_{\text{Air}}$ ratio of ≥ 2
- 5 kPa with a $P_{\text{Gas}} / P_{\text{Air}}$ ratio of ≤ 2

permitted for the governor, the pressure must be lowered with a reducing T-piece AGA78 (also refer to «Technical data»).

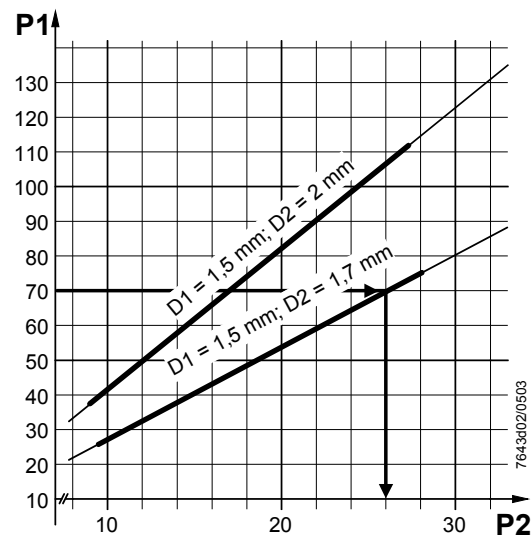

Example:

$p_1 = 7 \text{ kPa}$

$D_1 = 1.5 \text{ mm}$

$D_2 = 1.7 \text{ mm}$

Wanted: Air pressure signal «p2» for SKP75

$p_2 = 2,6 \text{ kPa}$

Air is continuously vented to atmosphere via orifice «D2». The pressure of the following medium will be reduced via throttle «D1». The illustration below shows the correlations.

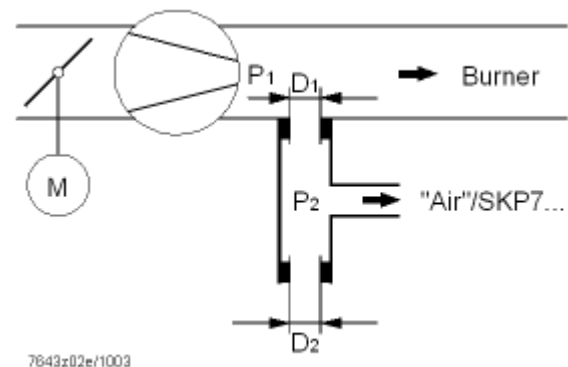
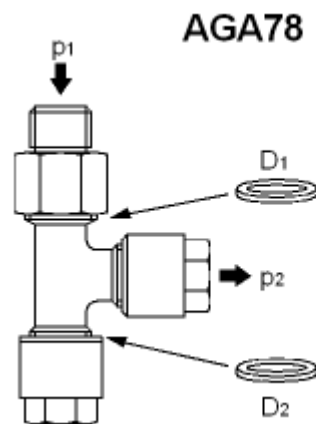

The reducing T-piece AGA78 is supplied ready for mounting, with $D_1 = 1.5 \text{ mm}$ and $D_2 = 1.7 \text{ mm}$.

D_2 with a diameter of 2 mm is included as a loose item.

Standards and certificates

In combination with
VGx



Applied directives:

- Low-voltage directive 2006/95/EC
- Directive for gas-fired appliances 2009/142/EC
- Directive for pressure devices 97/23/EC
- Electromagnetic compatibility EMC (immunity) *) 2004/108/EC

*) Compliance with EMC emissions requirements must be checked after the actuator has been installed in the work equipment

Compliance with the regulations of the applied directives is verified by the adherence to the following standards / regulations:

- Pressure regulators and associated safety devices for gas appliances
Part 1: Pressure regulators for inlet pressures up to and including 50 kPa DIN EN 88-1
- Multifunctional controls for gas burning appliances DIN EN 126
- Automatic shut-off valves for gas burners and gas appliances DIN EN 161
- Safety and control devices for gas burners and gas burning appliances DIN EN 13611
- Automatic electrical controls for household and similar use
Part 1: General requirements DIN EN 60730-1

The relevant valid edition of the standards can be found in the declaration of conformity!



EAC Conformity mark (Eurasian Conformity mark)



ISO 9001:2008
ISO 14001:2004
OHSAS 18001:2007



China RoHS
Hazardous substances table:
<http://www.siemens.com/download?A6V10883536>

For use in the U.S. / Canada, the actuators carry type suffix «U» (see example) and are



and -listed (*Example:* SKP25.003U1, refer to separate Data Sheet [on request]).

Life cycle

The combination valve and actuator have a designed lifetime* of

Nominal size	Burner startup cycles
≤25 DN	200.000
25...80 DN	100.000
80...150 DN	50.000

which, under use of gases to EN 437 (or DVGW specification G260).

This lifetime is based on the endurance tests in the standard EN 161. A summary of the conditions has been published by the European Control Manufacturers Association (Afecor) (www.afecor.org).

The designed lifetime is based on use of the valve and actuator according to the manufacturer's Data Sheet. When reaching the designed lifetime in terms of the number of burner startup cycles or the respective time of usage, valve and actuator must be checked by authorized personnel and, if necessary, replaced.

* The designed lifetime is not the warranty time specified in the Terms of Delivery.

Disposal notes



The actuator contains electrical and electronic components and hydraulic oil and must not be disposed of together with domestic waste. Local and currently valid legislation must be observed.

Type summary (other types of actuators on request)

The complete gas shutoff assembly or pressure governor assembly consists of actuator and valve.

SKP15

	Article no.	Type	Article no.	Type
Mains voltage	AC 120 V		AC 230 V	
1-stage opening and closing, without end switch, without valve stroke indication	BPZ:SKP15.000E1	SKP15.000E1	BPZ:SKP15.000E2	SKP15.000E2
1-stage opening and closing, with end switch	BPZ:SKP15.001E1	SKP15.001E1	BPZ:SKP15.001E2	SKP15.001E2

Type summary (other types of actuators on request)

The complete gas shutoff assembly or pressure governor assembly consists of actuator and valve.

SKP25

	Article no.	Type	Article no.	Type
Mains voltage	AC 120 V		AC 230 V	
1-stage opening and closing, with end switch, with pressure governor up to 2,2 kPa, other pressure ranges via change setpoint spring possible → refer to accessories	BPZ:SKP25.001E1 ²⁾	SKP25.001E1 ²⁾	BPZ:SKP25.001E2 ²⁾	SKP25.001E2 ²⁾
1-stage opening and closing, without end switch, with pressure governor up to 2,2 kPa, other pressure ranges via change setpoint spring possible → refer to accessories	BPZ:SKP25.003E1 ²⁾	SKP25.003E1 ²⁾	BPZ:SKP25.003E2 ²⁾	SKP25.003E2 ²⁾
1-stage opening and closing, without end switch, with pressure governor up to 2,2 kPa, other pressure ranges via change setpoint spring possible, with integrated damping throttle AGA25.2 → refer to Accessories	---	---	BPZ:SKP25.003E2Y	SKP25.003E2Y
2-stage opening and closing, with end switch, with pressure governor up to 6 kPa	BPZ:SKP25.201E1	SKP25.201E1	BPZ:SKP25.201E2	SKP25.201E2
2-stage opening and closing, without end switch, with pressure governor up to 2 kPa	BPZ:SKP25.201E1L	SKP25.201E1L	BPZ:SKP25.201E2L	SKP25.201E2L
2-stage opening and closing, without end switch, with pressure governor up to 6 kPa	---	---	BPZ:SKP25.203E2	SKP25.203E2
2-stage opening and closing, without end switch, with pressure governor up to 2 kPa	---	---	BPZ:SKP25.203E2L	SKP25.203E2L
1-stage opening and closing, with end switch, with stroke indication, proportionate governor version	---	---	BPZ:SKP25.301E2 [*])	SKP25.301E2 [*])
1-stage opening and closing, without end switch, proportionate governor version	---	---	BPZ:SKP25.303E2	SKP25.303E2
1-stage opening and closing, with end switch, with pressure governor up to 150 kPa, high-pressure version, other pressure ranges via change setpoint spring possible → refer to accessories	BPZ:SKP25.401E1 ³⁾	SKP25.401E1 ³⁾	BPZ:SKP25.401E2 ^{3)*)}	SKP25.401E2 ^{3)*)}
1-stage opening and closing, without end switch, with pressure governor up to 150 kPa, high-pressure version, other pressure ranges via change setpoint spring possible → refer to accessories	BPZ:SKP25.403E1 ³⁾	SKP25.403E1 ³⁾	BPZ:SKP25.403E2 ³⁾	SKP25.403E2 ³⁾
1-stage opening and closing, with end switch, for zero pressure governor version	---	---	BPZ:SKP25.601E2 [*])	SKP25.601E2 [*])
1-stage opening and closing, without end switch, for zero pressure governor version	---	---	BPZ:SKP25.603E2 [*])	SKP25.603E2 [*])

¹⁾ Factory setting 1,5 kPa

²⁾ Factory setting 120 kPa

^{*}) On request

Type summary (other types of actuators on request)

SKP55

	Article no.	Type	Article no.	Type
Mains voltage	AC 120 V		AC 230 V	
1-stage opening and closing, with end switch, with differential pressure governor	BPZ:SKP55.001E1	SKP55.001E1	BPZ:SKP55.001E2	SKP55.001E2
1-stage opening and closing, without end switch, with differential pressure governor	BPZ:SKP55.003E1	SKP55.003E1	BPZ:SKP55.003E2	SKP55.003E2

SKP75

	Article no.	Type	Article no.	Type
Mains voltage	AC 120 V		AC 230 V	
1-stage opening and closing, with end switch, with ratio pressure governor	BPZ:SKP75.001E1	SKP75.001E1	BPZ:SKP75.001E2	SKP75.001E2
1-stage opening and closing, without end switch, with ratio pressure governor	BPZ:SKP75.003E1	SKP75.003E1	BPZ:SKP75.003E2	SKP75.003E2
1-stage opening and closing, with end switch, with ratio pressure governor, with greater parallel displacement	---	---	BPZ:SKP75.501E2	SKP75.501E2
1-stage opening and closing, without end switch, with ratio pressure governor, with greater parallel displacement	BPZ:SKP75.503E1	SKP75.503E1	BPZ:SKP75.503E2	SKP75.503E2

²⁾ Factory setting 1,5 kPa

Ordering examples

When ordering, please give the complete type reference of the actuator (refer to «Type summary»). All components must be ordered as separate items.

Example of SKP15

Actuator with safety shutoff function

- Open / closed
- With end switch
- For AC 230 V / 50 Hz

Connector valve actuator (plug)

Connector end switch (plug)

SKP15.001E2

AGA64

AGA65

Combination of actuator / valve consisting of:

- Valve
- SKP15.001E2 actuator
- Accessories

Please order the required valves as separate items (refer to the relevant Data Sheets). Actuator and valve are supplied unassembled. Assembly is very straightforward and preferably made on the burner.

Example of SKP25

Gas pressure governor with safety shutoff function:

- Without end switch
- For AC 230 V / 50 Hz

Connector valve actuator (plug)

SKP25.003E2

AGA64

Combination of gas pressure governor / valve consisting of:

- Valve
- SKP25.003E2 actuator



Adapter plug

AGA62.000A000

Article no.: **BPZ:AGA62.000A000**

For powering both actuators on the double valve VGD via plug (AGA64)

Example: SKP15 / SKP25.2 with adapter plug AGA62.000A000

Central connection via AGA64 for the **separate** control of valves 1 and valves 2
Facilitates valve proving via pressure switch between the valves or ignition via pilot burner

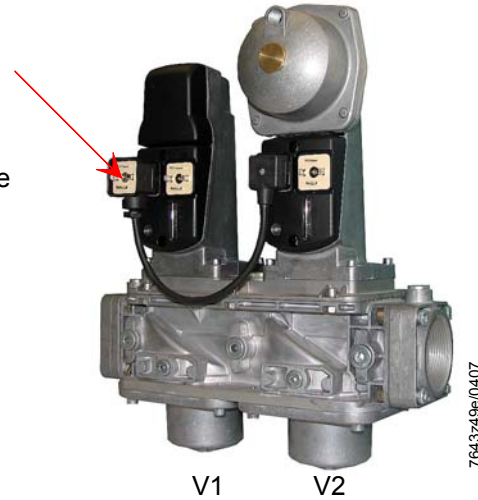

Heating element

AGA63.5A27

Article no.: **BPZ:AGA63.5A27**

- Refer to Data Sheet N7923
- For use at low ambient temperatures (< -10...-20 °C)





Contact box for valve actuator (power supply)

AGA64

Article no.: **BPZ:AGA64**

- Plug-in connector conforming to DIN EN 175301-803-A
- 3 pole + \oplus
- Dia. 6...9 mm / max. 1.5 mm²

Example: SKP15 / SKP25 with contact box AGA64



Contact box for end switch

AGA65

Article no.: **BPZ:AGA65**

- Plug-in connector conforming to DIN EN 175301-803-A
- 3 pole + \oplus
- Dia. 4.5...11 mm / max. 1.5 mm²

Example: SKP15 / SKP75 with contact box AGA65

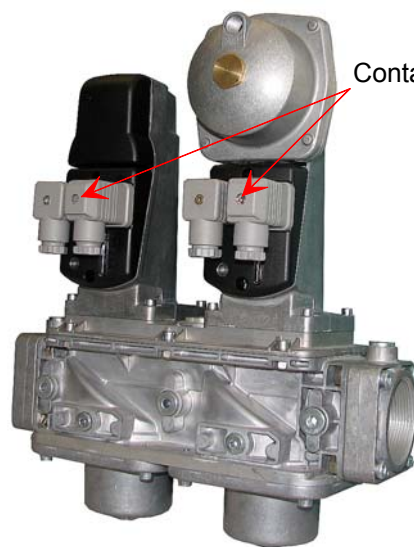

Contact box end switch AGA65

V1 V2

7643250e/0407

Contact box

AGA67

Article no.: **BPZ:AGA67**



- For powering the magnetic actuator SKP25.2
- Plug-in connector conforming to DIN EN 175301-803-A
- With integrated bridge rectifier
- 2 pole + \oplus
- Dia. 6...8 mm / max. 1.5 mm²
- Including profile seal

Example: SKP15 / SKP25 with contact box AGA67

Contact box AGA67



Adapter plug for AGA62.000A000

AGA68

Article no.: **BPZ:AGA68**







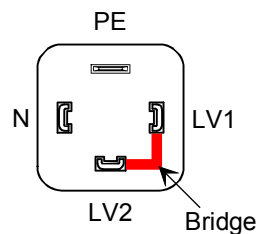
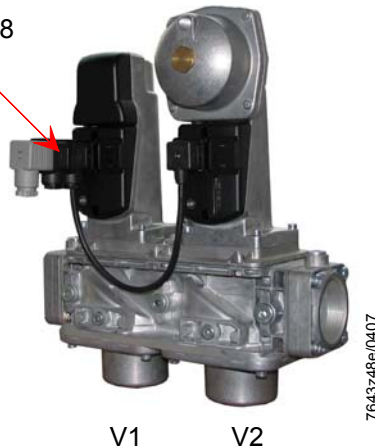

For common valve control

Example: SKP15 / SKP25 with adapter plug AGA68

Adapter plug AGA68



Accessories (not supplied as standard, to be ordered as separate items) (cont'd)

	Article no.	Type
 <p>Motorized setpoint adjuster for SKP25.0</p> <ul style="list-style-type: none"> • For 5.5 mm stroke • See Data Sheet N4581 and Mounting Instructions A5W00000658 (M7643) 		SAS...
 <p>Adaptation to SKP25 For motor pressure correction in conjunction with motorized setpoint adjuster SAS. For more details, refer to Mounting Instructions A5W00000658.</p>	S55851-Z401-A100	AGA30.7
<p>Setpoint spring (yellow / gold) for SKP25</p> <ul style="list-style-type: none"> • Optional for built-in standard spring AGA29 • 1,5...12 kPa at SKP25.0 • 7...70 kPa at SKP25.4 (optional for AGA23) 	BPZ:AGA22	AGA22
 <p>Setpoint spring (red) for SKP25</p> <ul style="list-style-type: none"> • Optional for built-in standard spring AGA29 • 10...25 kPa at SKP25.0 • 15...150 kPa at standard spring SKP25.4 	BPZ:AGA23	AGA23
<p>Setpoint spring (blank) for SKP25.3</p> <ul style="list-style-type: none"> • Equivalent built-in standard spring • $\pm 0,15$ kPa 	BPZ:AGA28	AGA28
<p>Setpoint spring (blank) for SKP25.0</p> <ul style="list-style-type: none"> • Equivalent built-in standard spring • 0,05...2,2 kPa 	BPZ:AGA29	AGA29
 <p>Damping throttle for SKP25 Optional</p>	BPZ:AGA25.2	AGA25.2
 <p>Damping throttle for SKP55 / SKP75</p> <ul style="list-style-type: none"> • Optional, pipe connection for 6 mm dia. • Refer to Mounting Instructions 4 319 2078 0 	BPZ:AGA75	AGA75
 <p>Pressure reducing-T-piece for SKP75 Optional</p>	BPZ:AGA78	AGA78

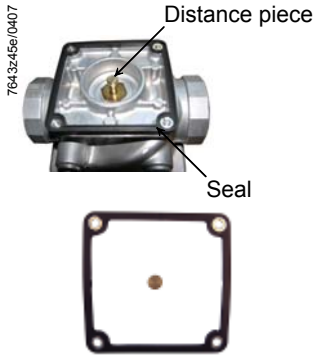

Gasket set

- For mounting between actuator and valve (VGx / VRx)
- Increases degree of protection from IP54 to IP65
- When using VGG single valves, observe Data Sheet N7636
- Refer to Mounting Instructions M7643.2 (74 319 0421 0)

AGA66
Article no.: **BPZ:AGA66**



Setpoint fine adjustment to SKP25
Packaging version with one setpoint spring each
See Mounting Instructions M7643 (74 319 0926 0)

AGA30...

Article no.	Type	Setpoint spring		
		1.5...12 kPa Color: Yellow 1	10...25 kPa Color: Red 2	10...36 kPa Color: Blank 3
BPZ:AGA30.0	AGA30.0	●		
BPZ:AGA30.1	AGA30.1		●	
BPZ:AGA30.2	AGA30.2			●

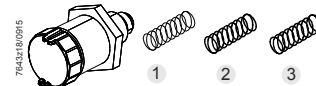



Note!
All typical technical information applies to nominal conditions.

General unit data

Mains voltage	
- Europe	
→ SKPx5.xxxE2	AC 230 V -15%/+10%
→ SKPx5.xxxE1	AC 120 V -15%/+10%
- Japan	
→ SKPx5.xxxF1	AC 100 V -15%/+10%
→ SKPx5.xxxF2	AC 200 V -7%/+10%
Mains frequency	
- Europe	50 / 60 Hz ±6%
- Japan	60 Hz ±6%
Power consumption	Protection 1 A slow
European	
→ SKPx5.xxxEx	Max. 10 VA
→ SKP25.xxxEx	Max. 35 VA (in stage 2)
Japan	
→ SKPx5.xxxFx	Max. 13 VA
Closing time	
→ SKPx5	<1 s (at shutdown)
Required time interval load change carried via air / fuel ration pressure between high-fire and low-fire	
→ SKP25.3 / SKP55 / SKP75	Min. 4 s (depending on valve stroke)
Safety class	I
Degree of protection	
→ SKPx5	IP54 → only ensured when central screw at the connector is tightened
	IP65 → only with gasket kit AGA66
→ SKP25 / SKP55	→ only with screwed-on locking caps



Note!
Degree of protection IP54 and IP65 only possible with mounted connectors.

Group 1	In accordance with DIN EN 88-1
Pollution degree	2
Rated surge voltage	Overvoltage category III in accordance with DIN EN 60730-1
Mode of operation	Automatic controller and control unit: Type 2C
Design of the controller and control unit	Integrated controller and control unit
Control class	A to DIN EN 88-1
Control accuracy	
→ SKP25.3 / SKP75	<10 % at «Δpmin», <2 % at «Δpmax»
→ SKP55	<10 % at «Δpmin», <1 % at «Δpmax»
Pressure impulse SKPx5	Static compressive strength as with valve VGx
Control variable gas pressure	
→ SKP25.0	0,05...25 kPa (3 setpoint springs)
→ SKP25.2	0,2...6 kPa
→ SKP25.2xxxxL	0,2...2 kPa
→ SKP25.3	0,05...5 kPa
→ SKP25.4	7...150 kPa (2 setpoint springs)
→ SKP25.6	<0 kPa (atmosphere)
→ SKP55	Difference pressure PG+ / PG- 0,03...20 kPa
→ SKP75 / SKP75.5	Difference pressure PG-PF or PG-PAir 0,08...12 kPa

Technical Data (cont'd)

Absolute / difference pressure of combustion air (reference variable)	
→ SKP25.3	0.05...7.5 kPa
→ SKP55	Difference pressure PL+ / PL- 0,03...20 kPa
→ SKP75 / SKP75.5	PAir-PCombustion space >0,05 kPa
Air pressure / difference pressure	
- at «PGas / PAir» ≥ 2	Max. 3 kPa
- at «PGas / PAir» ≤ 2	Max. 5 kPa
- Upper pressures refer to AGA78 «Accessories»	Max. 15 kPa
Difference pressure ratio (gas / air) adjustable	
→ SKP25.3 / SKP55	1:1
→ SKP75 / SKP75.5	0,4...9 (Factory supplied 1.3)
Permissible combustion space pressure	
→ SKP75	3 kPa
Parallel translation P _{Gas}	
→ SKP25.3 / SKP55	±0,1 kPa
→ SKP25.6	0 kPa/-0,9 kPa
→ SKP75	±0,1 kPa (Factory supplied 0)
→ SKP75.5	+0,1 kPa/-0,45 kPa (Factory supplied 0)
Position switch (if built-in)	As closed position switch factory-made justified
	Position valve CLOSED or OPEN
- Switching load	4 A (2 A, cosφ = 0.3) Protection 6 A slow



Notice!

Safety extra-low voltage may not be connected.

If this is not observed, there will be a risk of electric shock!

On-time	100 %
Opening speed, typical (approx.. 2 mm/s)	Lower opening speeds due to low ambient temperatures can be compensated by fitting an AGA63.5A27 heating element
Permissible mounting positions	

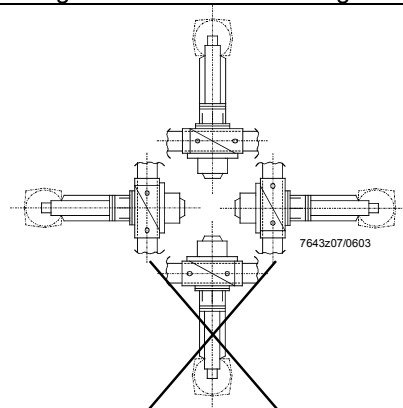

Always with the diaphragms in the vertical position

Technical Data (cont'd)

Weight	
→ SKP15	Approx. 1.1 kg
→ SKP25	Approx. 1.6 kg
→ SKP25.0	Approx. 1.6 kg
→ SKP25.2	Approx. 2.1 kg
→ SKP55	Approx. 1.9 kg
→ SKP75	Approx. 2.3 kg
→ AGA64	Approx. 30 g
→ AGA65	Approx. 36 g
→ AGA62.000A000	Approx. 66 g
Permissible media	Depending on used valve
Media inlet pressure «PE»	Depending on used valve
Permissible media temperature	Depending on used valve
Flow rate	Depending on used valve
Permissible test pressure «PG»	100 kPa
Permissible under pressure «PG»	20 kPa
Gas family	I...III

Environmental conditions

Storage	DIN EN 60721-3-1
Climatic conditions	Class 1K3
Mechanical conditions	Class 1M2
Temperature range	-15...+60 °C
Humidity	<95 % r.h.
Transport	DIN EN 60721-3-2
Climatic conditions	Class 2K2
Mechanical conditions	Class 2M2
Temperature range	-15...+60 °C
Humidity	<95 % r.h.
Operation	DIN EN 60721-3-3
Climatic conditions	Class 3K3
Mechanical conditions	Class 3M3
→ SKP25.0 with AGA30.7 and SAS	See <i>Use</i>
	No classification «-M-» (restricted operating conditions)
Temperature range	-10...+60 °C (longer opening times below 0 °C) -20...+60 °C (with heating element AGA63.5A27)
Temperature range	-5...+55 °C
Mechanical conditions	
→ SKP25.2	-10...+50 °C (restricted operating conditions)
→ SKP25.0 with AGA30.7 and SAS	-4...+54 °C (restricted operating conditions)
Humidity	<95 % r.F.
Installation altitude	Max. 2,000 m above sea level

Connection of actuator
(front-view)

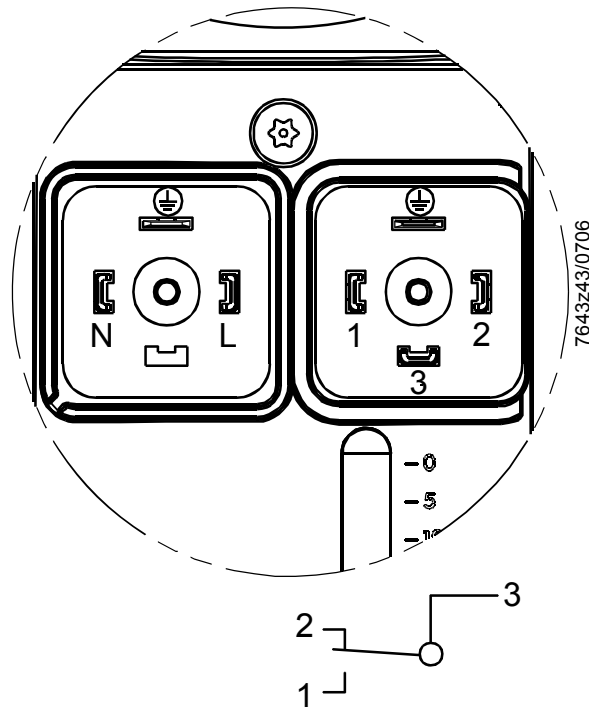

Valve actuator
Connection via AGA64
DIN EN 175301-803-A

End switch
Connection via AGA65
DIN EN 175301-803-A

(Only with SKPxx.xx1xx)

← If valve closed



Dimensions

Dimensions in mm

Actuators SKP15

Example: SKP15.000

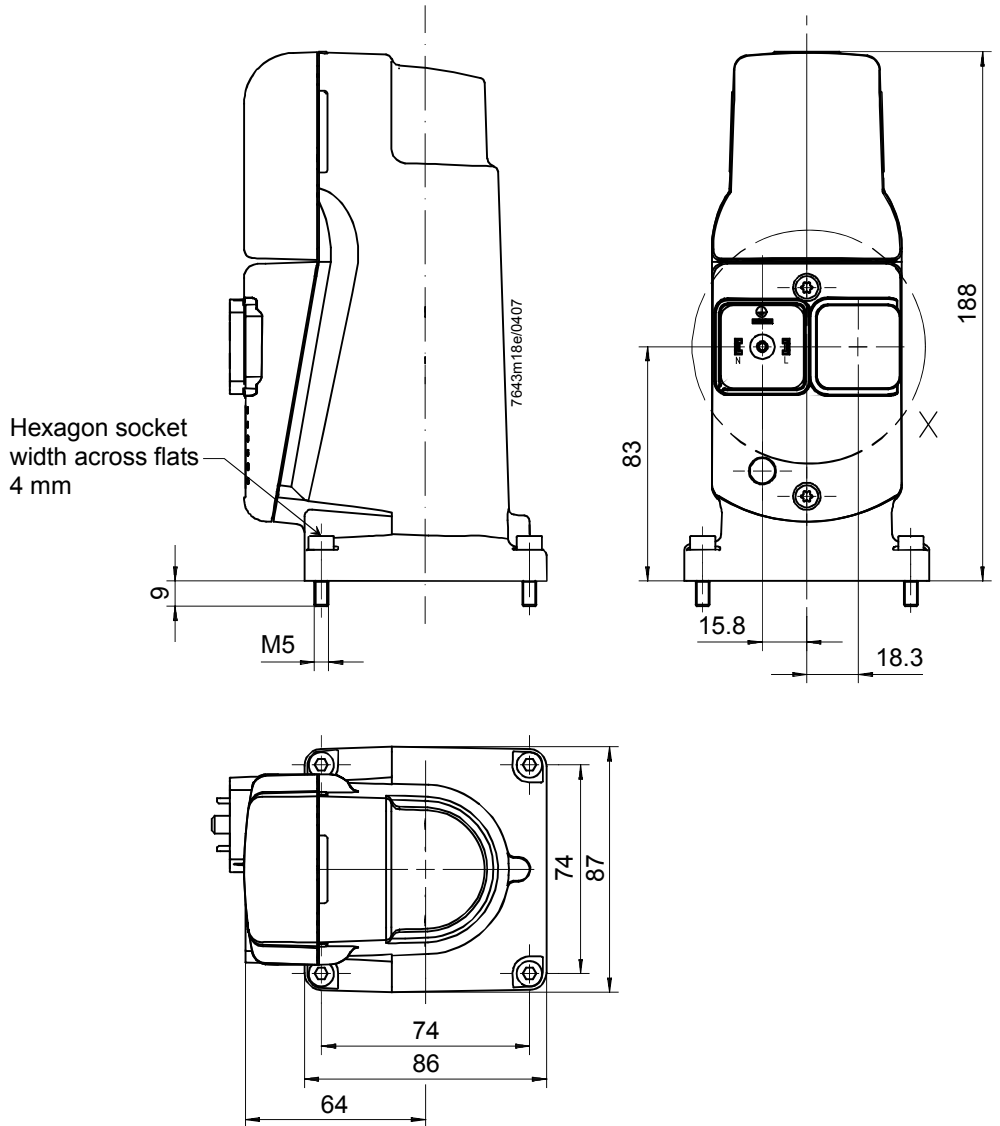

SKP15.000 (no valve stroke indication)

SKP15.001

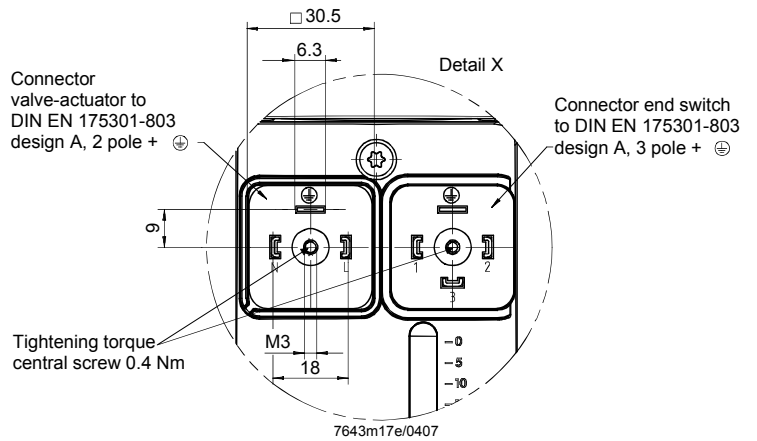
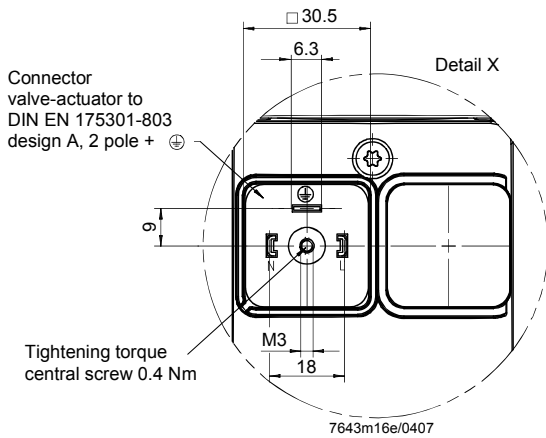

Dimensions in mm

Actuator SKP25.0 /
SKP25.3 / SKP25.6

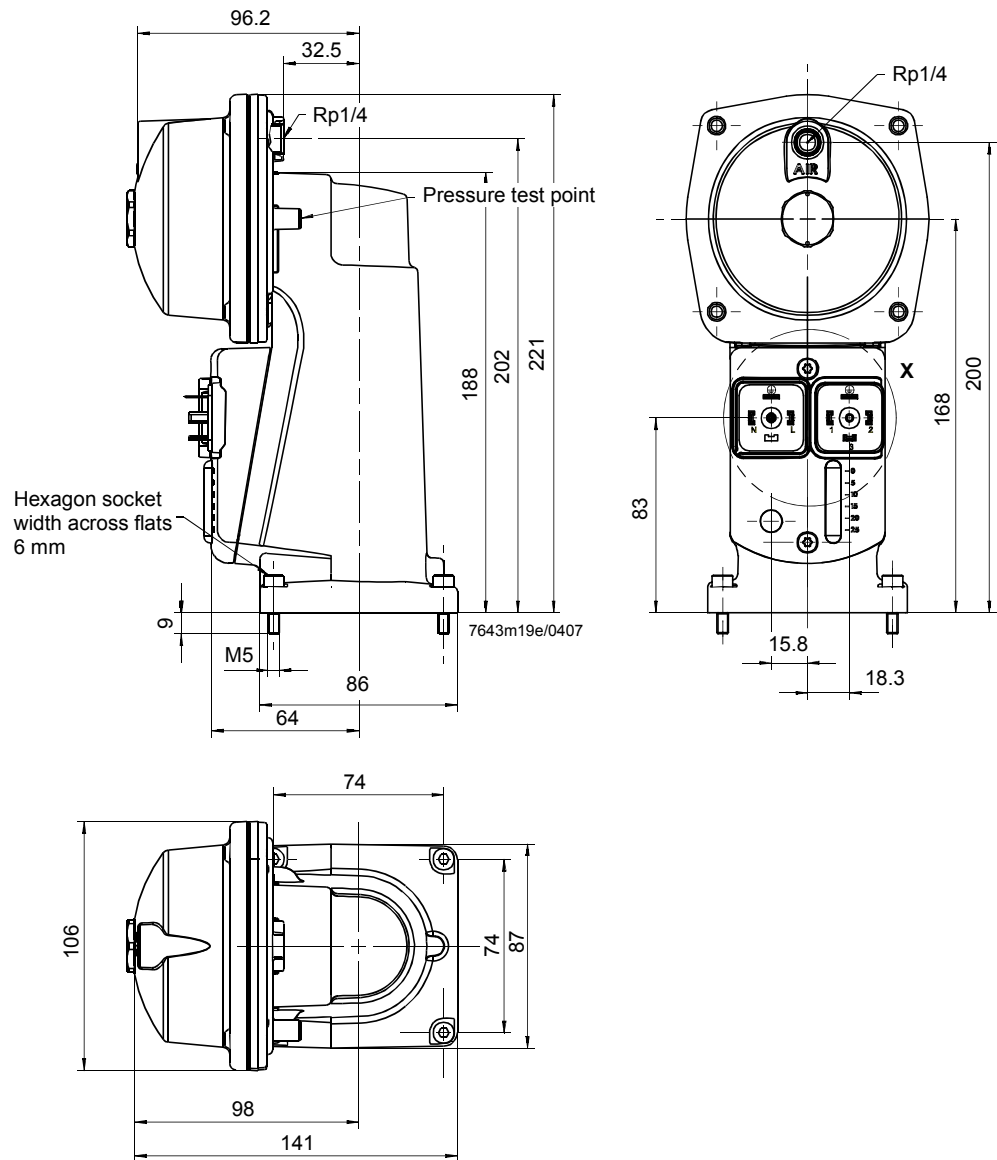

SKP25.001

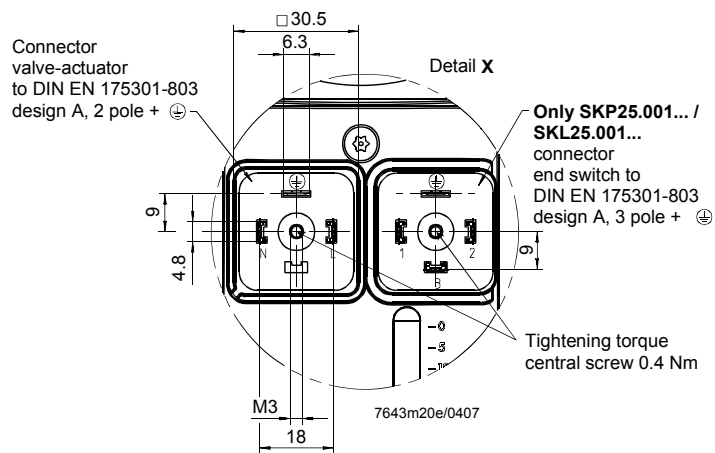

Dimensions (continued)

Dimensions in mm

Actuator SKP25.0 with
AGA30.7 and SAS)

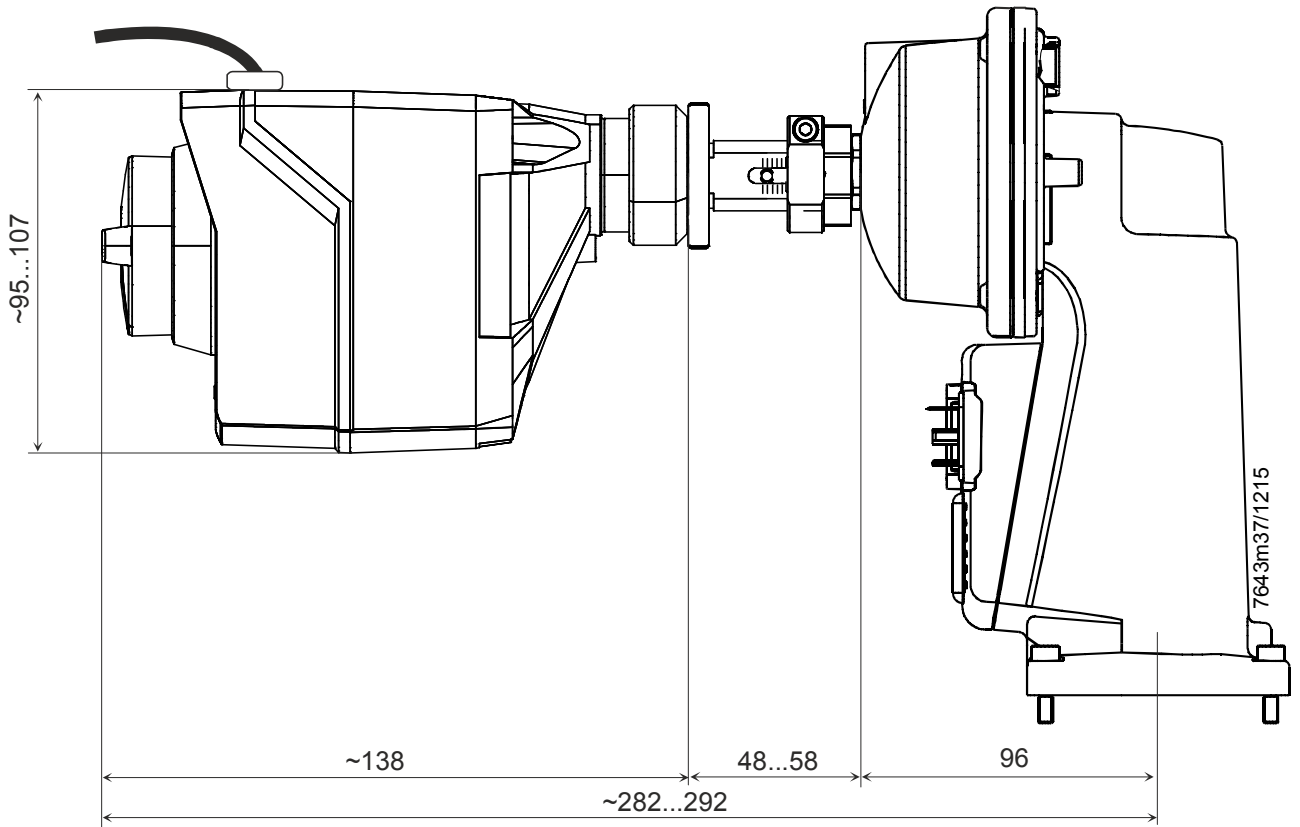

Dimensions (continued)

Dimensions in mm

SAS motorized setpoint adjuster

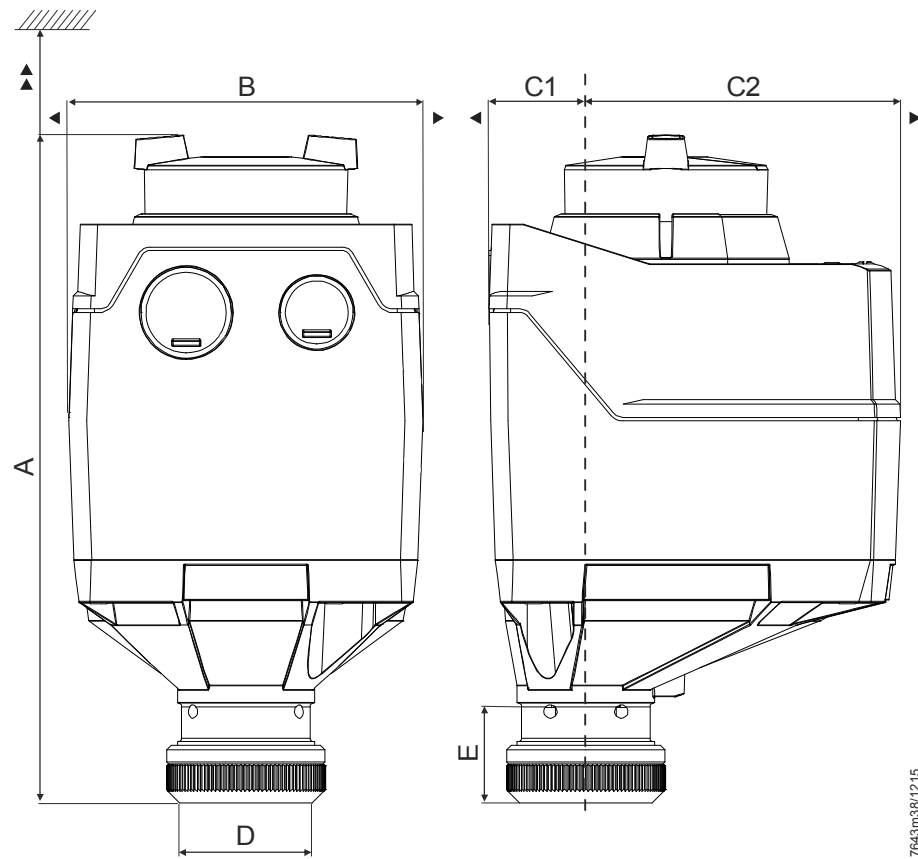

7643m38/12.15

Type	A	B	C	C1	C2	D	E	▶	▶▶	Kg
Without ASK39.2	137.6 ¹⁾ 151 ²⁾	80	106.5	21.9	84.6	29.9	21.8	100	200	0.68

Dimensions (cont'd)

Dimensions in mm

Actuator SKP25.2

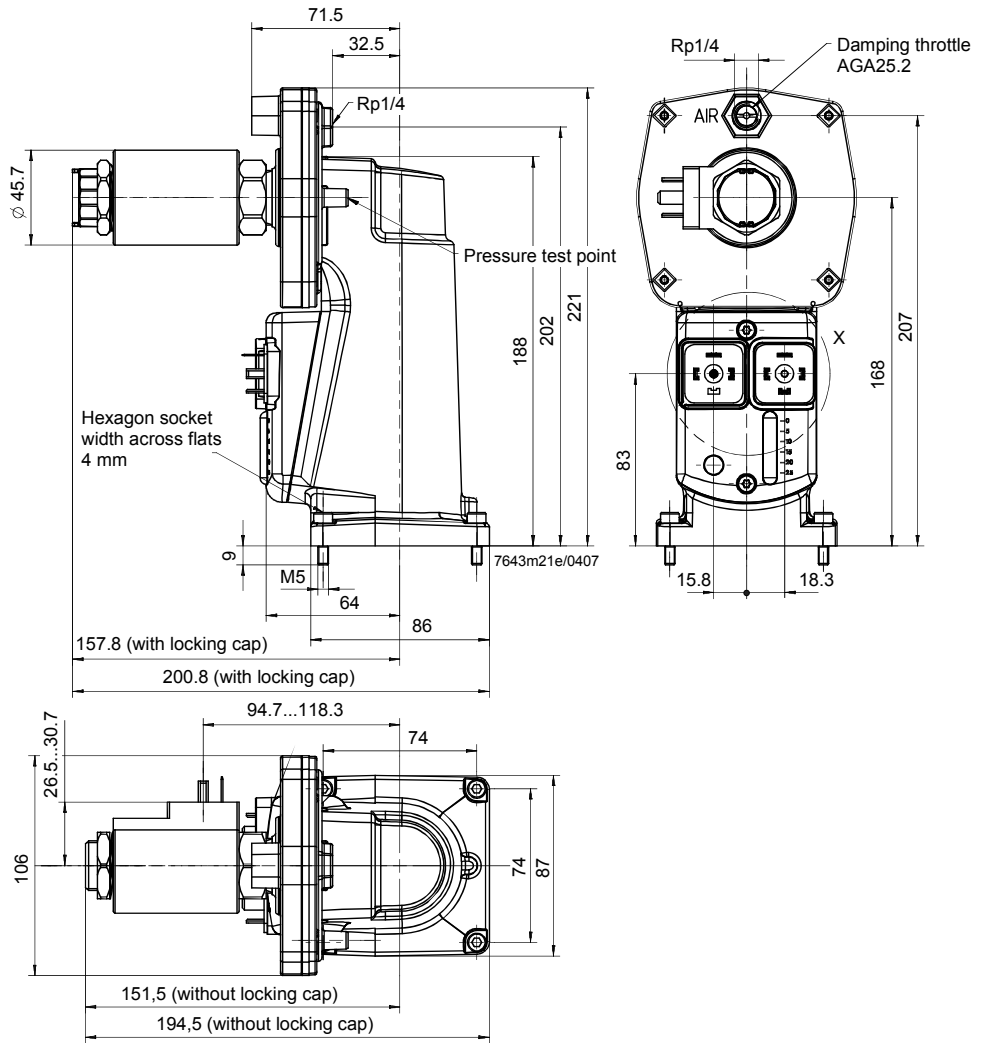

SKP25.201

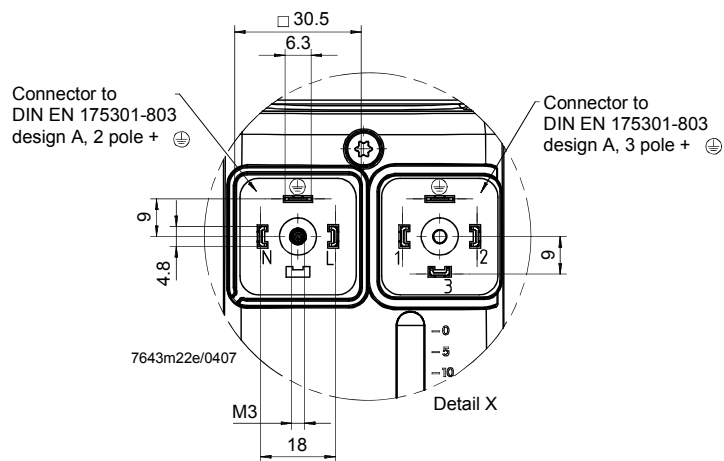

Dimensions in mm

Actuators SKP25.4

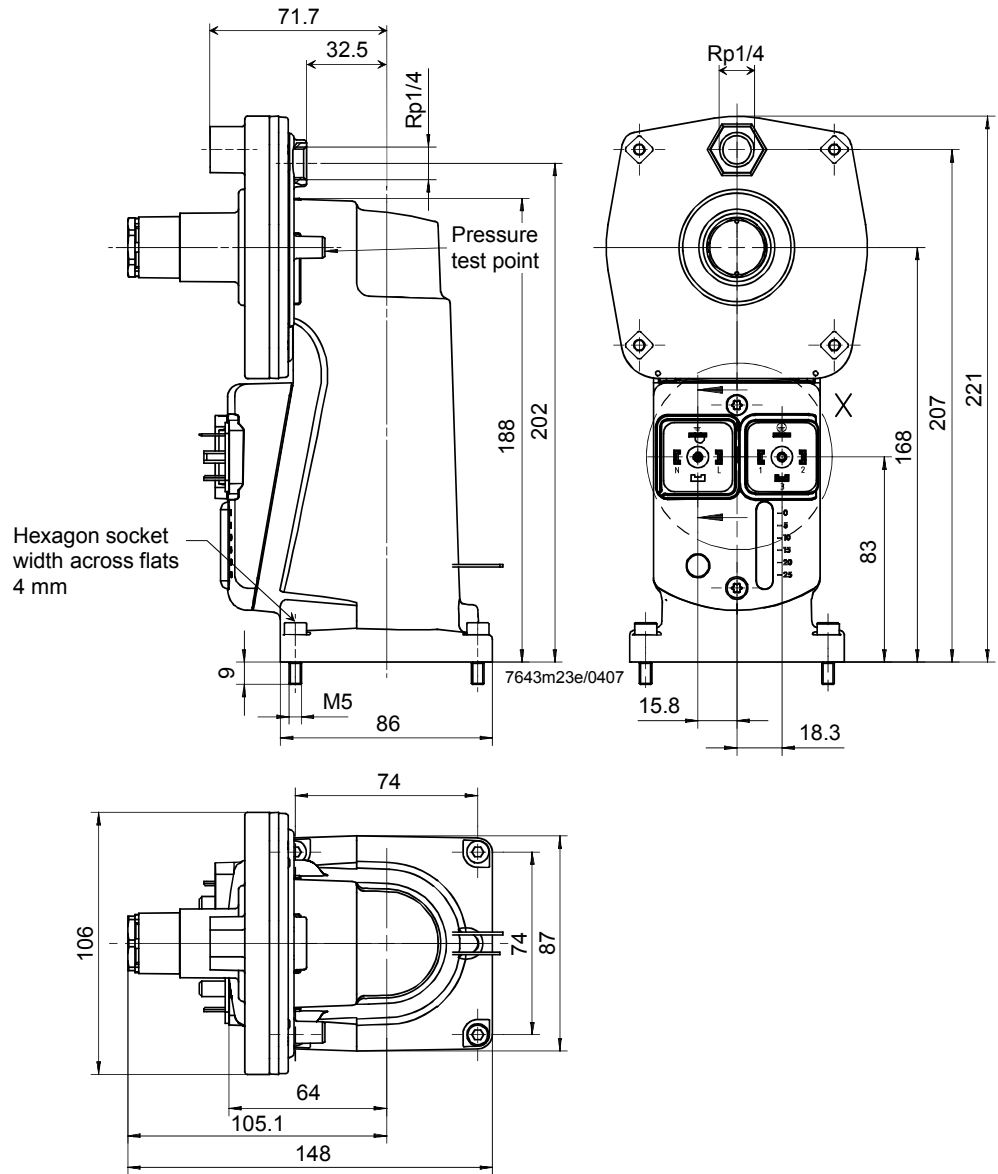

SKP25.401

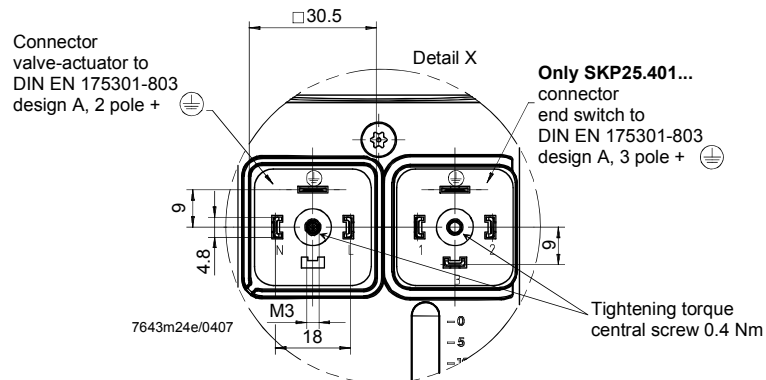

Dimensions (cont'd)

Dimensions in mm

Actuators SKP55

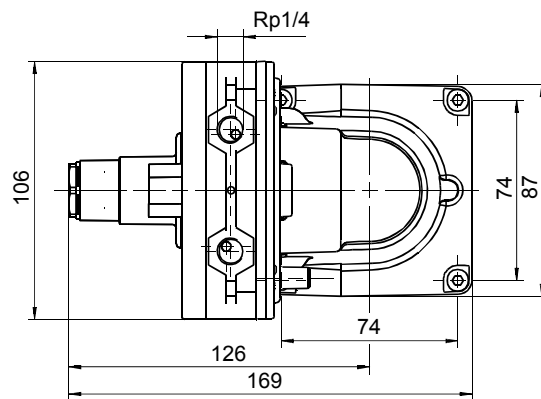
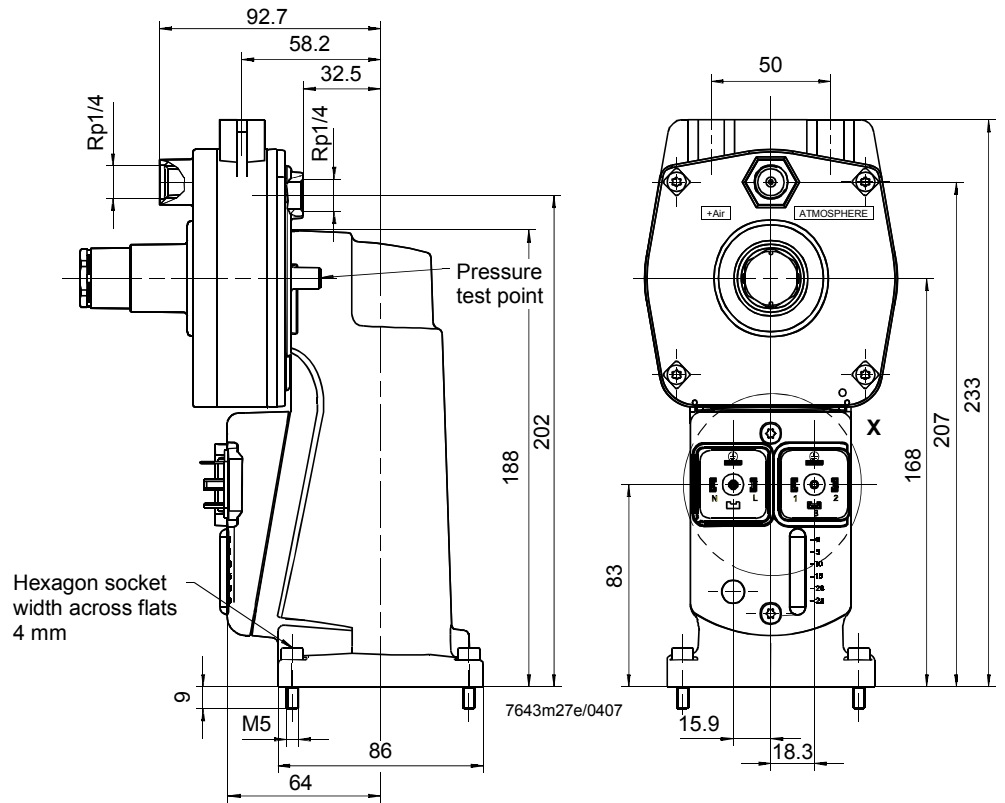

SKP55.001

Connector valve-actuator to DIN EN 175301-803 design A, 2 pole + ⊕

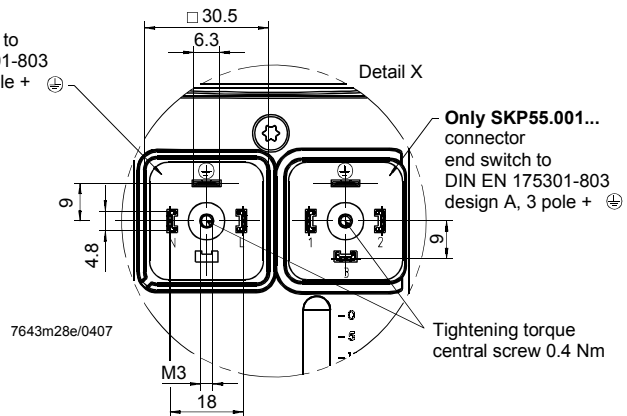

Dimensions in mm

Actuators SKP75

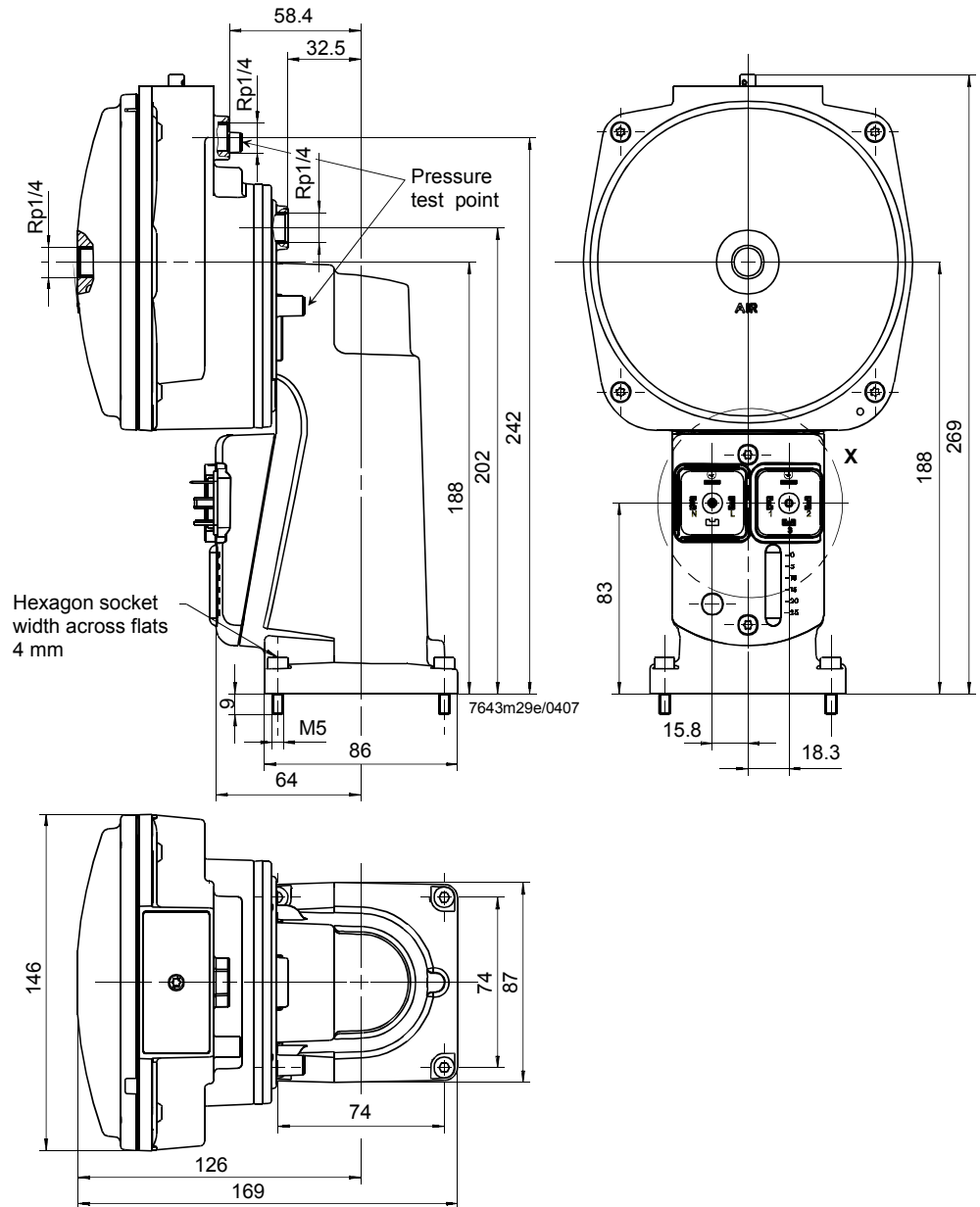

SKP75.001

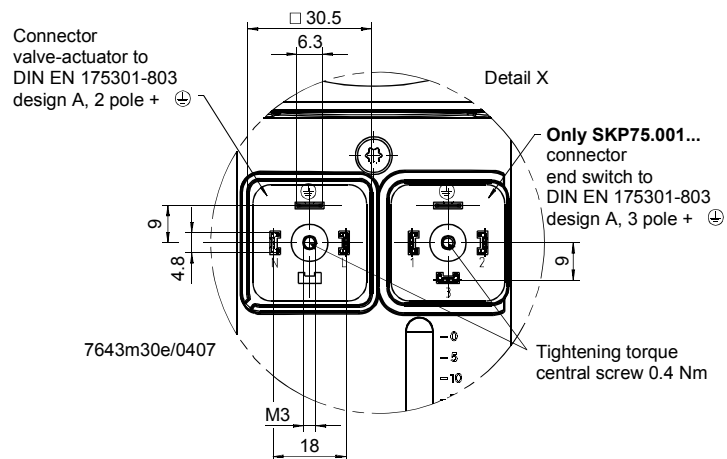

Dimensions (cont'd)

Adapter plug
AGA62.000A000

Dimensions in mm

- For 2 actuators mounted on one double valve

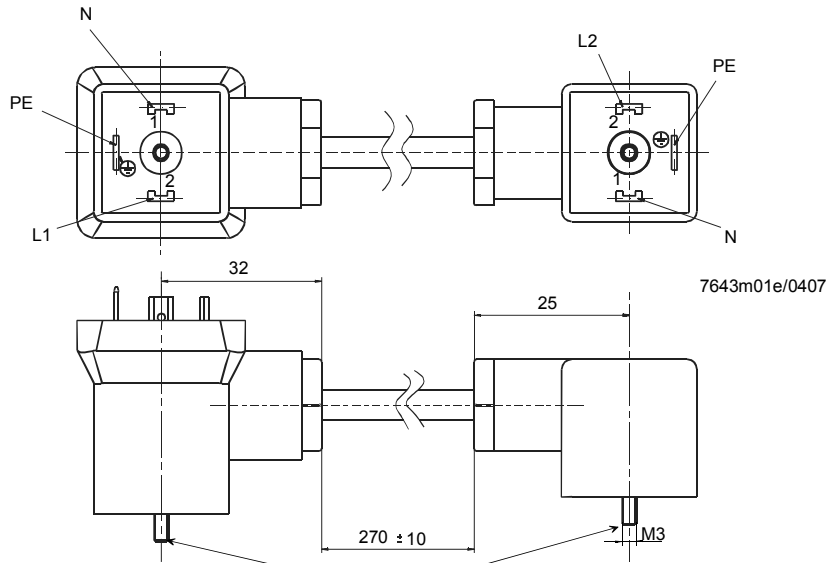

Tightening torque
central screw 0.4 Nm

Connection diagram

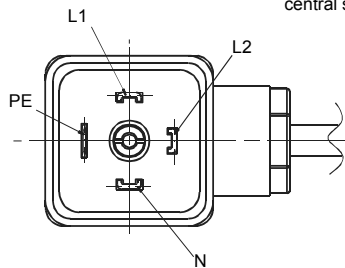
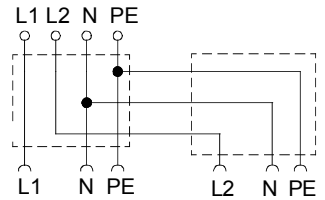

AGA30.x

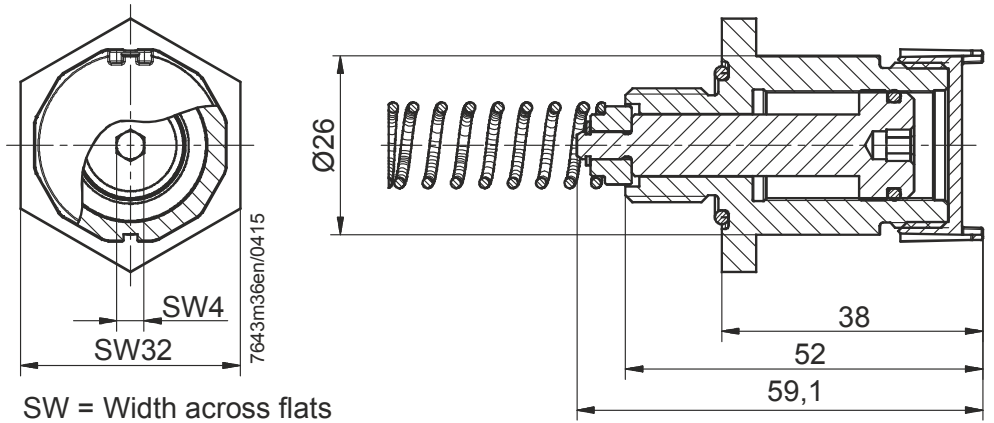

SW = Width across flats