

Types R622E and R652E 2-PSI (0,14 bar) Service Regulators

Introduction

The Types R622E and R652E 2-PSI (0,14 bar) service regulators are Underwriters Laboratories listed regulators designed for Two PSI (0,14 bar) LP-Gas systems. The units are installed downstream from a first-stage regulator to reduce an inlet pressure of 10 psig (0,69 bar) to a nominal 2 psig (0,14 bar) outlet pressure. The 2 PSIG (0,14 bar) LP-Gas is supplied to a line regulator located inside the building. In most cases a manifold is used with corrugated stainless steel tubing (CSST) as well as other acceptable piping materials for routing to the line regulator. The Type R622E incorporates the standard straight-through body while the Type R652E is designed for back mount installations. Both units have white closing caps for easy identification of the 2 psig (0,14 bar) setting. Screened drip-lip vents are oriented over the inlet as standard.

Features

- **20-Year Recommended Replacement Life** — The Types R622E and R652E are designed using rugged time proven design concepts with enhancements to the corrosion resistance and durability of materials, both internally and externally. With proper installation and periodic inspection and maintenance the Types R622E and R652E designs have a 20 Year Recommended Replacement Life. In some environmental conditions earlier replacement may be required.
- **Improved Regulations** — Fisher's large molded fabric-reinforced diaphragm and spring assisted vent stabilizer deliver accurate, stable regulation.

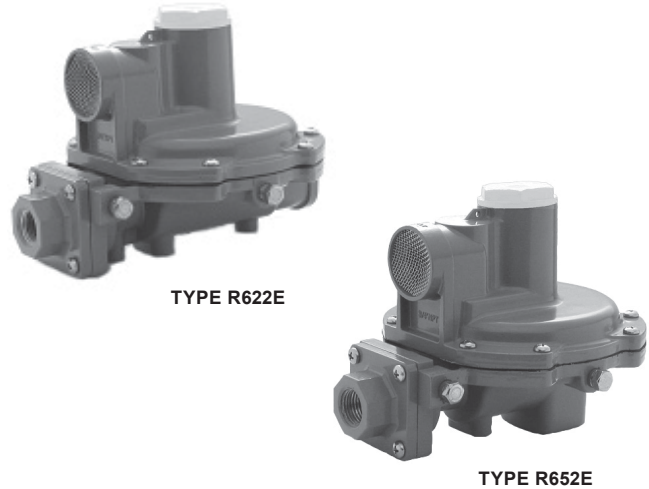

Figure 1. Type R622E and R652E 2-PSI Service Regulators

- **Superior Overpressure Protection** — The combination of a high capacity relief valve and large vent provide overpressure protection which exceeds UL standards.
- **Inlet Screen** — Fisher's stainless steel inlet screen reduces the amount of debris entering the regulator.
- **Easy System Checks** — 1/8 inch NPT inlet and outlet gauge taps orificed to a number 54 drill size are easily accessible for gas system checks.
- **Positive Drainage** — When installed properly with the spring case pointed down the Fisher Positive Drainage design allows any moisture formed in the spring case to drain out eliminating the problems with corrosion and freezing of the water in the spring case.

Table 1. Ordering Information

TYPE NUMBER	CAPACITY BTU/HR PROPANE ⁽¹⁾	CONNECTIONS INLET x OUTLET	OUTLET ADJUSTMENT SETTING	OUTLET PRESSURE RANGE
R622E-BCH	1,250,000	1/2 inch x 1/2 inch FNPT	2 psig (0,14 bar)	1 to 2.2 psig (0,07 to 0,15 bar)
R622E-DCH	1,500,000	3/4 inch x 3/4 inch FNPT		
R652E-DFH	1,400,000			

1. Capacities are based on 10 psig (0,69 bar) inlet pressure and 20% droop.



Bulletin LP - 7: R622E / R652E

Table 2. Selected Capacities for Type R622E/R652E Second-Stage Regulators

OUTLET PRESSURE SETTING, SPRING RANGE	INLET PRESSURE, PSIG (bar)	CAPACITIES IN THOUSANDS BTU/HR PROPANE ⁽¹⁾		
		Type R622E		Type R652E
		1/2-Inch (DN 15) Body	3/4-Inch (DN 20) Body	3/4-Inch (DN 20) Body
2 psig (0,14 bar) setting, 1 to 2.2 psig (0,07 to 0,15 bar)	5 (0,34)	930	1,030	930
	10 (0,69)	1,460	1,680	1,500

1. Capacities are based on 20 inch w.c. (50,00 mbar) droop.

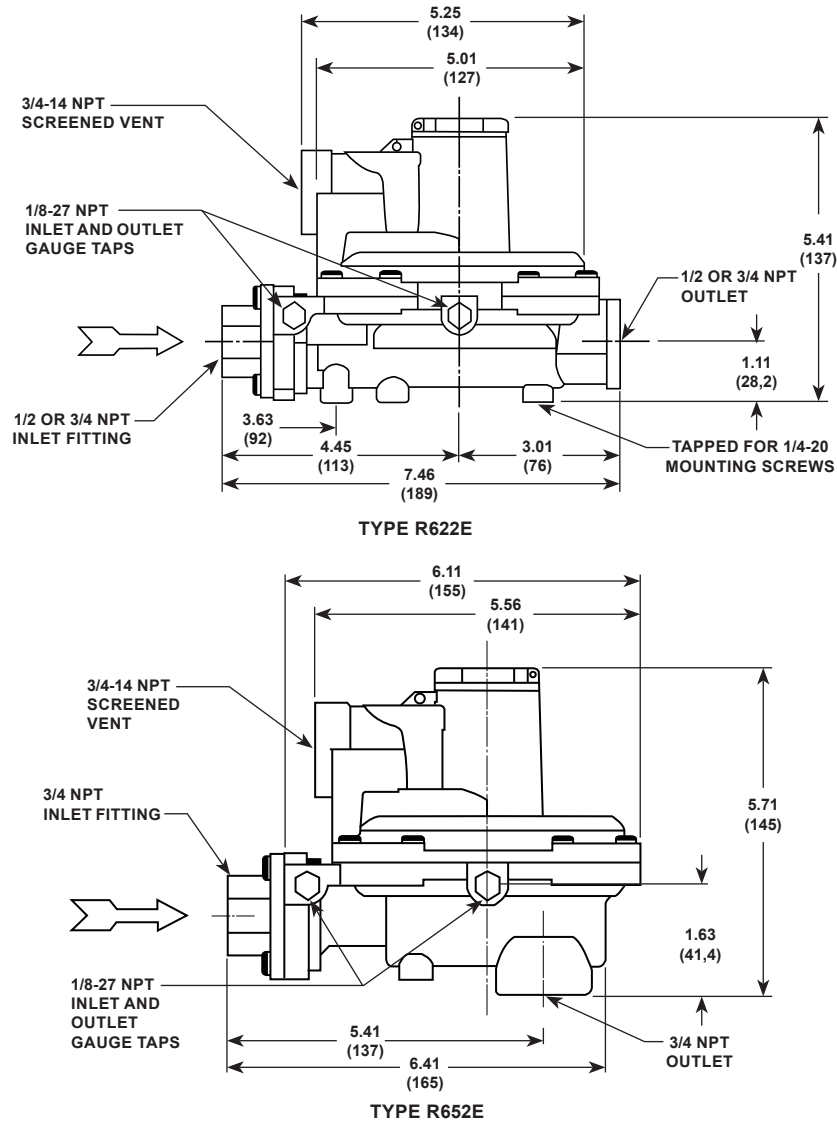

Figure 4. Types R622E and R652E Dimensions Inches (mm)

Fisher and Fisher Regulators are marks owned by Fisher Controls International, LLC. The Emerson logo is a trademark and service mark of Emerson Electric Co. All other marks are the property of their respective owners.

The contents of this publication are presented for informational purposes only, and while every effort has been made to ensure their accuracy, they are not to be construed as warranties or guarantees, expressed or implied, regarding the products or services described herein or their use or applicability. We reserve the right to modify or improve the designs or specifications of such products at any time without notice.

Fisher does not assume responsibility for the selection, use or maintenance of any product. Responsibility for proper selection, use and maintenance of any Fisher product remains solely with the purchaser.

Emerson Process Management

Fisher Controls International, LLC.
 P.O. Box 8004
 McKinney, Texas 75070, USA
 Telephone: 1 (800) 558-5853
 Telephone: 1 (469) 293-4201

