



Ex II 3G Ex ec IIC T4 Gc

Ex II 3D Ex tc IIIB T125°C Dc



RoHS II
COMPLIANT



Data sheet

DE90

Differential pressure transmitter
PRO-LINE®

09015202 • DB_EN_DE90 • Rev. ST4-F • 06/20

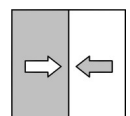

1 Product and functional description

1.1 Performance characteristics

Typical applications

- Space and clean room monitoring
- Supply and exhaust air systems, TNV systems
- Dynamic filter monitoring
- Filter monitoring
- Flow rate measurement
- Surface coating systems
- Process monitoring

Important features

- Robust, resistant to overpressure and maintenance-free
- Simple configuration
- Measuring ranges from
 - 25 Pa to 25 kPa
 - 1 mbar to 250 mbar
- Measuring accuracy up to 0.5%
- Turn Down 4:1
- Optionally one or two-channel mode with
 - Configurable output signal
0/4 ... 20 mA, 0/2 ... 10 V or 1...5V
 - Characteristic curve implementation and adjustment to the process
 - 1 to 4 configurable switching outputs
- Multi-line LC display
 - Full graphic, colour backlighting for visualising the operating states
 - Multilingual plain text menu
- Digital interfaces
 - USB OTG
 - RS485 Modbus RTU

1.2 Intended use

The DE90 is a differential pressure transmitter with additional switch outputs. It is suitable for measuring overpressure, under-pressure and differential pressure in neutral gaseous media.

The device may only be used for the purpose stipulated by the manufacturer. The manufacturer will not be liable for damage arising from incorrect or improper use.

1.2.1 Explosion hazard area classification

1.2.1.1 Gas explosion protection

Devices with the order code **DE90 ### ## ## # 0 # 000 R1 # #** are suitable as 'Electrical equipment for use in potentially explosive areas', Zone 2 - Gases and vapours.

Designation as per Directive 2014/34/EU:

⊕ II 3G Ex ec IIC T4 Gc

1.2.1.2 Dust explosion protection

Devices with the order code **DE90 ### ## ## # 0 # 000 R1 # #** are suitable as 'Electrical equipment for use in areas with combustible dust', Zone 22 - dry dusts.

Designation as per Directive 2014/34/EU:

⊕ II 3D Ex tc IIIB T125°C Dc

$-10^{\circ}\text{C} \leq T_{\text{amb}} \leq 60^{\circ}\text{C}$

1.3 Function diagram

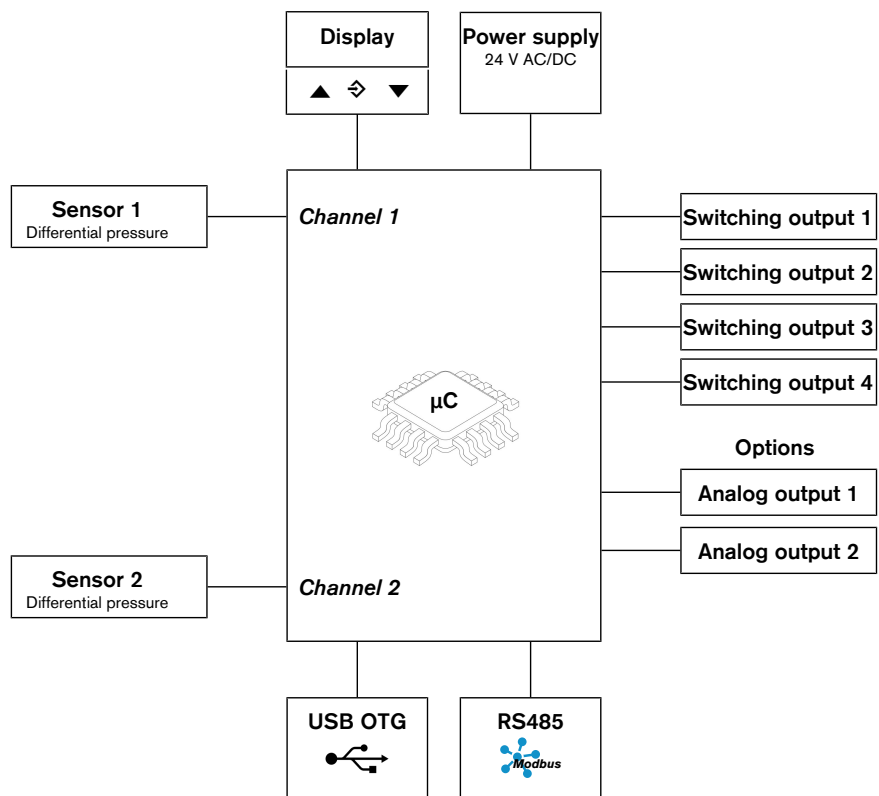

Fig. 1: Function diagram

1.4 Design and mode of operation

The device is based on a piezo-resistive sensor element that is suitable for measuring overpressure, under-pressure and differential pressure. The pressures to be compared directly act on a silicon diaphragm equipped with a measuring bridge.

When the pressure is equal, the measuring membrane is in rest position. If a pressure difference occurs, the membrane is deflected, causing a change in resistance of the applied measuring bridge. This change is evaluated by the electronics integrated in the instrument and converted into display and up to four switching contacts.

The device can optionally be equipped with up to two analog outputs. The output signal can be attenuated, spread, inverted and also non-linearly transformed via a table function.

Overall, the unit can be supplied with the following equipment.

	1 channel	2 channel	Modbus RTU
Schaltausgang 1	X	X	
Schaltausgang 2	X	X	
Schaltausgang 3		X	
Schaltausgang 4		X	
USB Schnittstelle	X	X	X
RS485 Modbus RTU			X
Optionen:			
Analogausgang 1	X	X	
Analogausgang 2		X	

1.5 Equipment versions

Process connections

The presented connections are used for all models.

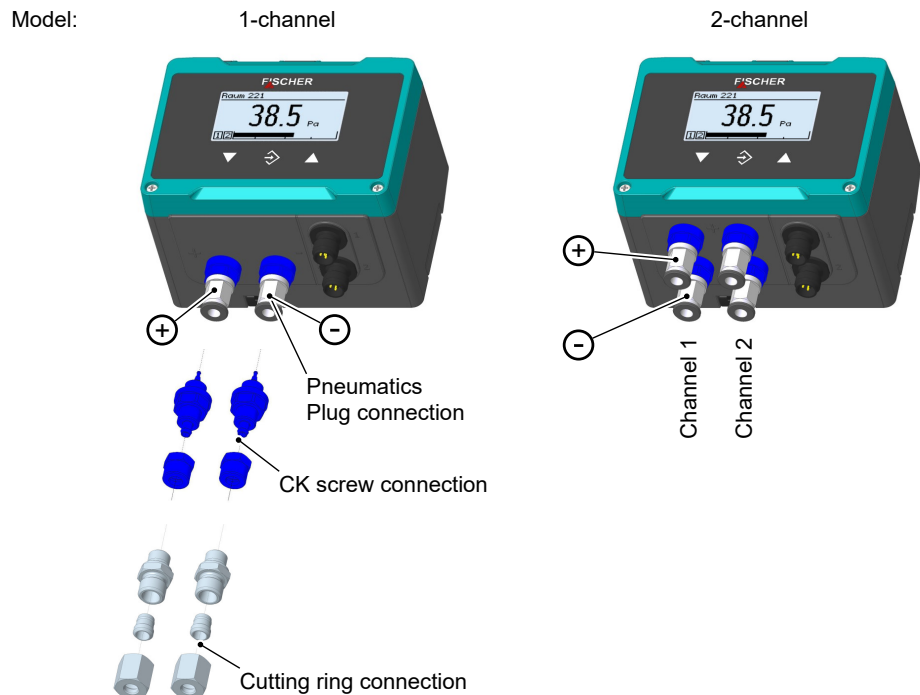

Fig. 2: Process connections

Electrical connections

Two M12 flange connectors are used for the electrical connection.

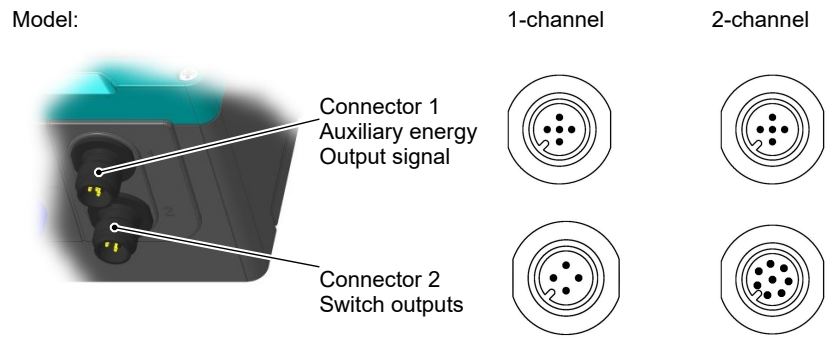

Fig. 3: Electrical connections

ATEX Version



Fig. 4: ATEX Version

2 Technical data

2.1 General

Type designation	DE90	
Pressure type	Differential pressure	
Measurement principle	Piezo-resistive	
Reference conditions (acc. to IEC 61298-1)		
Temperature	+15 ... +25 °C	
Relative humidity	45 ... 75 %	
Air pressure	86 ... 106 kPa	860 ... 1060 mbar
Installation position	vertical	

2.2 Input variables

Asymmetric measuring ranges:

Measuring range (Channel 1 2)	Overload	Bursting pressure	Sensor type
-20 ... +80 Pa	750 mbar	1 bar	A
0 ... 25 Pa	750 mbar	1 bar	A
0 ... 40 Pa	750 mbar	1 bar	A
0 ... 60 Pa	750 mbar	1 bar	A
0 ... 1 mbar	750 mbar	1 bar	A
0 ... 1.6 mbar	750 mbar	1 bar	A
0 ... 2.5 mbar	750 mbar	1 bar	A
0 ... 4 mbar	100 mbar	200 mbar	B
0 ... 4 mbar	750 mbar	1 bar	A *
0 ... 6 mbar	100 mbar	200 mbar	B
0 ... 6 mbar	750 mbar	1 bar	A *
0 ... 10 mbar	100 mbar	200 mbar	B
0 ... 10 mbar	750 mbar	1 bar	A *
0 ... 16 mbar	400 mbar	800 mbar	B
0 ... 25 mbar	400 mbar	800 mbar	B
0 ... 40 mbar	400 mbar	800 mbar	B
0 ... 60 mbar	1 bar	2 bar	B
0 ... 100 mbar	1 bar	2 bar	B
0 ... 160 mbar	2.5 bar	5 bar	B
0 ... 250 mbar	2.5 bar	5 bar	B

^{*)} Measuring range with increased overload and burst pressure capability (see order code/special features).

Symmetric measuring ranges:

Measuring range (Channel 1 2)	Overload	Bursting pressure	Sensor type
-25 ... +25 Pa	750 mbar	1 bar	A
-40 ... +40 Pa	750 mbar	1 bar	A
-60 ... +60 Pa	750 mbar	1 bar	A
-1 ... +1 mbar	750 mbar	1 bar	A
-1.6 ... +1.6 mbar	750 mbar	1 bar	A
-2.5 ... +2.5 mbar	100 mbar	200 mbar	B

Measuring range (Channel 1 2)		Overload	Bursting pressure	Sensor
-2,5 ... +2,5 mbar	-250 ... +250 Pa	750 mbar	1 bar	A *
-4 ... +4 mbar	-400 ... +400 Pa	100 mbar	200 mbar	B
-4 ... +4 mbar	-400 ... +400 Pa	750 mbar	1 bar	A *
-6 ... +6 mbar	-600 ... +600 Pa	100 mbar	200 mbar	B
-6 ... +6 mbar	-600 ... +600 Pa	750 mbar	1 bar	A *
-10 ... +10 mbar	-1 ... +1 kPa	100 mbar	200 mbar	B
-10 ... +10 mbar	-1 ... +1 kPa	750 mbar	1 bar	A *
-16 ... +16 mbar	-1.6 ... +1.6 kPa	400 mbar	800 mbar	B
-25 ... +25 mbar	-2.5 ... +2.5 kPa	400 mbar	800 mbar	B
-40 ... +40 mbar	-4 ... +4 kPa	400 mbar	800 mbar	B
-60 ... +60 mbar	-6 ... +6 kPa	1 bar	2 bar	B
-100 ... +100 mbar	-10 ... +10 kPa	1 bar	2 bar	B
-160 ... +160 mbar	-16 ... +16 kPa	2.5 bar	5 bar	B
-250 ... +250 mbar	-25 ... +25 kPa	2.5 bar	5 bar	B

*) Measuring range with increased overload and burst pressure capability (see order code/special features).

2.3 Output sizes

Analog outputs

The number of analog outputs depends on the device version.

Device Version	1-channel	2-channel
Number of analog outputs	1	2

The output signal can be set by parameterization. On delivery, both analog outputs are set to the same signal (see nameplate).

Output signal	0 ... 20 mA 4 ... 20 mA	0 ... 10 V 2 ... 10 V 1 ... 5 V
Signal range	0.0 ... 21.5 mA	0.0 ... 10.5 V
Load R_L	$\leq 600 \Omega$	$\geq 2 \text{ k}\Omega$
Turn down	4:1	4:1

Switching outputs

The number of switching outputs depends on the device version. The assignment of the switching outputs to the channels can be freely parameterised.

Device Version	1-channel	2-channel
Number of switching outputs	2	4
Assignment on Delivery	Switch output 1 Switch output 2	Switch output 3 Switch output 4
Type	Potential-free semiconductor switch (MOS-FET)	
Progr. switching function	Single pole make contact (NO) Single pole break contact (NC)	
max. switching voltage	3...32 V AC/DC	
max. switching current	0.25 A	
max. switching capacity	8 W / 8 VA $R_{ON} \leq 4 \Omega$	

2.4 Measuring accuracy

- The specifications for the measurement deviation (e) include linearity and hysteresis.
- All specifications refer to the basic measuring range (see name plate) and a compensation range of -20 to +70 °C.

Sensor type A

Measuring range		Error of measurement (e) [%]		TK Zero point [%/10K]		TK Span [%/10K]	
		Typ.	Max.	Typ.	Max.	Typ.	Max.
	-20 ... +80 Pa	0.5	1.0	0.3	0.6	0.2	0.4
	0 ... 25 Pa	1.5	2.5	0.5	1.0	0.3	0.6
	0 ... 40 Pa	1.0	2.0	0.5	1.0	0.2	0.4
	0 ... 60 Pa	0.75	1.5	0.3	0.6	0.2	0.4
0 ... 1 mbar	0 ... 100 Pa	0.5	1.0	0.3	0.6	0.2	0.4
0 ... 1.6 mbar	0 ... 160 Pa	0.5	1.0	0.3	0.6	0.2	0.4
0 ... 2.5 mbar	0 ... 250 Pa	0.5	1.0	0.3	0.6	0.2	0.4
0 ... 4 mbar	0 ... 400 Pa	0.5	1.0	0.15	0.3	0.05	0.1
0 ... 6 mbar	0 ... 600 Pa	0.5	0.75	0.15	0.25	0.05	0.1
0 ... 10 mbar	0 ... 1 kPa	0.25	0.5	0.1	0.2	0.05	0.1
	-25 ... +25 Pa	1.0	2.0	0.4	0.8	0.2	0.4
	-40 ... +40 Pa	0.75	1.5	0.3	0.6	0.2	0.4
	-60 ... +60 Pa	0.5	1.0	0.3	0.6	0.2	0.4
-1 ... +1 mbar	-100 ... +100 Pa	0.5	1.0	0.3	0.6	0.2	0.4
-1.6 ... +1.6 mbar	-160 ... +160 Pa	0.5	1.0	0.3	0.6	0.2	0.4
-2.5 ... +2.5 mbar	-250 ... +250 Pa	0.5	1.0	0.15	0.3	0.05	0.1
-4 ... +4 mbar	-400 ... +400 Pa	0.5	1.0	0.1	0.2	0.05	0.1
-6 ... +6 mbar	-600 ... +600 Pa	0.5	0.75	0.1	0.15	0.05	0.1
-10 ... +10 mbar	-1 ... +1 kPa	0.25	0.5	0.05	0.1	0.05	0.1

Sensortyp B

Messbereich		Messabweichung (e) [%]		TK Nullpunkt [%/10K]		TK Spanne [%/10K]	
		Typ.	Max.	Typ.	Max.	Typ.	Max.
0 ... 4 mbar	0 ... 400 Pa	0.5	1.0	0.15	0.3	0.05	0.1
0 ... 6 mbar	0 ... 600 Pa	0.5	0.75	0.15	0.25	0.05	0.1
0 ... 10 mbar	0 ... 1 kPa	0.25	0.5	0.1	0.2	0.05	0.1
0 ... 16 mbar	0 ... 1.6 kPa	0.25	0.5	0.15	0.3	0.05	0.1
0 ... 25 mbar	0 ... 2.5 kPa	0.25	0.5	0.15	0.25	0.05	0.1
0 ... 40 mbar	0 ... 4 kPa	0.25	0.5	0.1	0.2	0.05	0.1
0 ... 60 mbar	0 ... 6 kPa	0.25	0.5	0.1	0.2	0.05	0.1
0 ... 100 mbar	0 ... 10 kPa	0.25	0.5	0.1	0.15	0.05	0.1
0 ... 160 mbar	0 ... 16 kPa	0.25	0.5	0.05	0.1	0.05	0.1
0 ... 250 mbar	0 ... 25 kPa	0.25	0.5	0.05	0.1	0.05	0.1
-2.5 ... +2.5 mbar	-250 ... +250 Pa	0.5	1.0	0.15	0.3	0.05	0.1
-4 ... +4 mbar	-400 ... +400 Pa	0.5	1.0	0.1	0.2	0.05	0.1
-6 ... +6 mbar	-600 ... +600 Pa	0.5	0.75	0.1	0.15	0.05	0.1
-10 ... +10 mbar	-1 ... +1 kPa	0.25	0.5	0.05	0.1	0.05	0.1

Messbereich		Messabweichung (e) [%]		TK Nullpunkt [%/10K]		TK Spanne [%/10K]	
		Typ.	Max.	Typ.	Max.	Typ.	Max.
-16 ... +16 mbar	-1.6 ... +1.6 kPa	0.25	0.5	0.1	0.2	0.05	0.1
-25 ... +25 mbar	-2.5 ... +2.5 kPa	0.25	0.5	0.1	0.15	0.05	0.1
-40 ... +40 mbar	-4 ... +4 kPa	0.25	0.5	0.05	0.1	0.05	0.1
-60 ... +60 mbar	-6 ... +6 kPa	0.25	0.5	0.05	0.1	0.05	0.1
-100 ... +100 mbar	-10 ... +10 kPa	0.25	0.5	0.05	0.1	0.05	0.1
-160 ... +160 mbar	-16 ... +16 kPa	0.25	0.5	0.05	0.1	0.05	0.1
-250 ... +250 mbar	-25 ... +25 kPa	0.25	0.5	0.05	0.1	0.05	0.1

2.5 Digital interfaces

USB interface

USB On The Go	2.0
Data rate	12 Mbit/s (Full Speed)
Port	Micro USB typee B
Communication	Host/Device mode

Modbus RTU interface

interface	RS 485
Report	Modbus RTU
Modbus specification	Application Protocol Specification V1.1b3 (April 26, 2012)
Address	1 ... 255
Baud rate	2400 ... 115200 Baud
Parity	Even, uneven, parity
Stopbits	1...2

2.6 Auxiliary energy

NOTICE! A CE-conform mains adapter with a slow 200 mA fuse only may be used in the power supply circuit for ATEX devices.

Nominal voltage	24 V AC/DC
Admissible operating voltage U_b	19.2 ... 28.8 V AC/DC
Power consumption	Type 2W (VA) Max. 3W (VA)

2.7 Operating conditions

	Standard	ATEX
Umgebungstemperaturbereich	-20 ... +70 °C	-20 ... +60 °C
Mediumtemperaturbereich	-20 ... +70 °C	-20 ... +60 °C
Lagerungstemperaturbereich	-20 ... +70 °C	-20 ... +70 °C
Schutzart	IP65	IP65
EMC	EN 61326-1:2013 EN 61326-2-3:2013	
ATEX	EN IEC 60079-0:2018 EN IEC 60079-7:2015/A1:2018 EN 60079-31:2014	
RoHS	EN IEC 63000:2018	

2.8 Display

Display	Full graphic LC display
Resolution	128 x 64 Pixel
Backlight	RGB
Measured value display	6 digits

2.9 Construction design

Process connection		Ø outside	Ø inside
CK screw connections made of aluminium	Hose	6 mm	4 mm
	Hose	8 mm	6 mm
Pneumatic connector socket in nickel-plated brass	Hose	6 mm	4 mm
	Hose	8 mm	6 mm
Cutting ring connection in stainless steel	Pipe	6 mm	
	Pipe	8 mm	

Electrical connection	1-channel	2-channel
Connector 1 : Auxiliary energy, output	5-pin male	5-pin male
Connector 2 : Switching outputs	4-pin male	8-pin male

Installation position	User-defined
Dimensions (without connections)	120 x 81.5 x 95 mm
Weight	max. 380 g

2.9.1 Materials

Materials of the parts that come into contact with the medium

Silicon, PVC, FKM, aluminium, brass, stainless steel

Materials of the parts that come into contact with the surroundings

Polyester, PET, polyamide 6.6, aluminium, nickel-plated brass, stainless steel

2.9.2 Dimensional drawings

All dimensions in mm unless otherwise stated

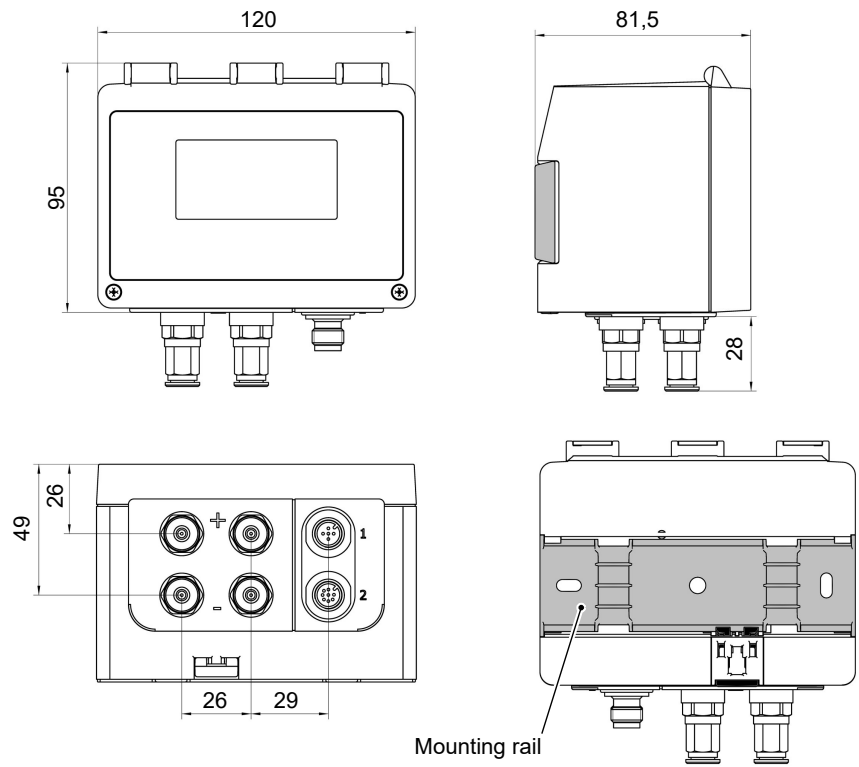

Fig. 5: Dimension drawing

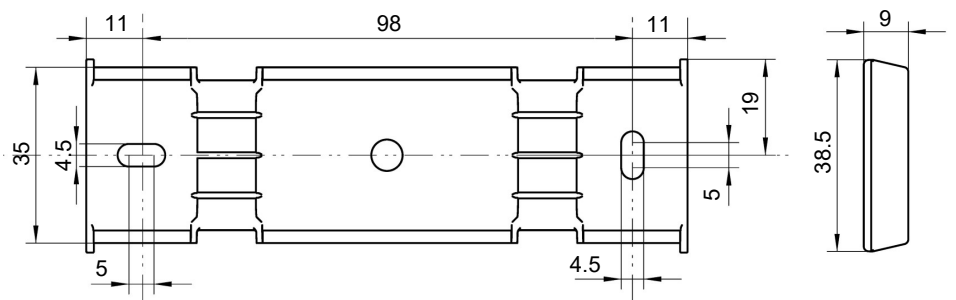

Fig. 6: Mounting rail

Process connections

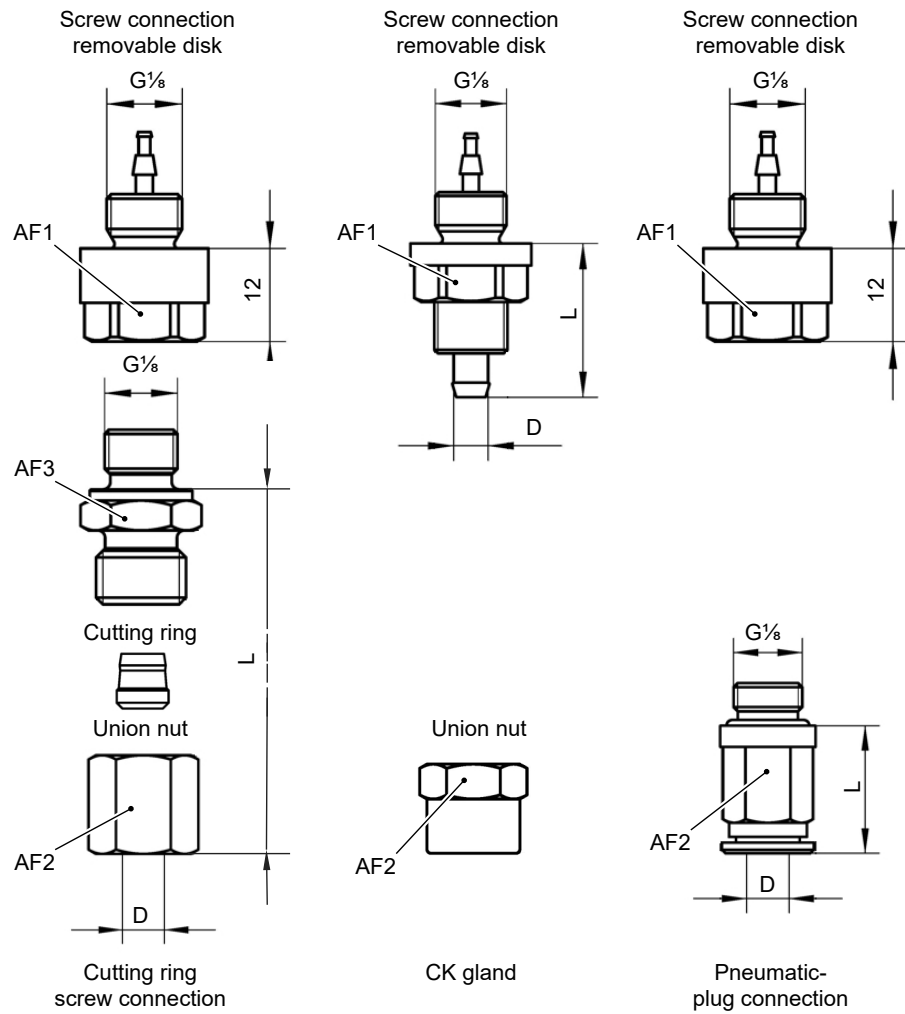
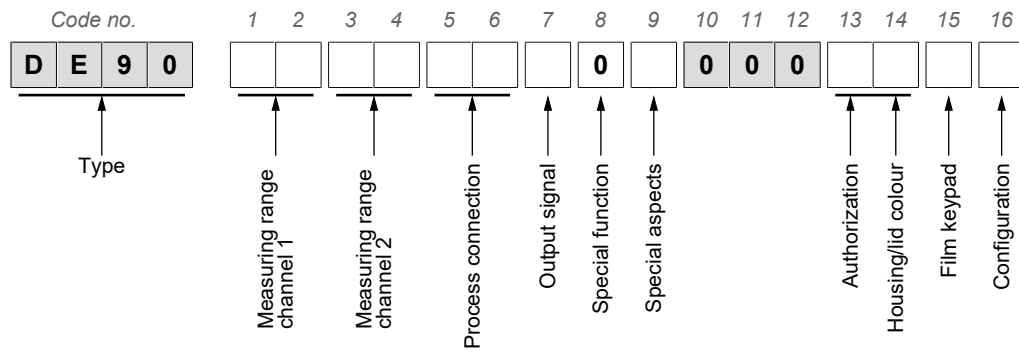

Fig. 7: Process connection Options

Prozessanschluss		D	d	L	AF1	AF2	AF3
Cutting ring screw connection	Pipe	6	---	23.5	14	14	14
		8	---	24.5	14	17	14
CK gland	Hose	6	4	21	14	12	---
		8	6	21	14	14	---
Pneumatic plug connection	Pneumatic hose	6	4	18	14	11	---
		8	6	20.5	14	13	---

D: outside diameter; d: inside diameter

3 Order codes



Measuring range channel 1:

[1,2]	[1,2]
	L0 -20 ... +80 Pa
	D1 0 ... 25 Pa
	D2 0 ... 40 Pa
	D3 0 ... 60 Pa
51 0 ... 1 mbar	D4 0 ... 100 Pa
97 0 ... 1.6 mbar	D5 0 ... 160 Pa
98 0 ... 2.5 mbar	D6 0 ... 250 Pa
52 0 ... 4 mbar	D7 0 ... 400 Pa
53 0 ... 6 mbar	D8 0 ... 600 Pa
54 0 ... 10 mbar	N1 0 ... 1 kPa
55 0 ... 16 mbar	N2 0 ... 1.6 kPa
56 0 ... 25 mbar	N3 0 ... 2.5 kPa
57 0 ... 40 mbar	N4 0 ... 4 kPa
58 0 ... 60 mbar	N5 0 ... 6 kPa
59 0 ... 100 mbar	E5 0 ... 10 kPa
60 0 ... 160 mbar	E6 0 ... 16 kPa
82 0 ... 250 mbar	E7 0 ... 25 kPa
	L5 -25 ... +25 Pa
	R6 -40 ... +40 Pa
	2L -60 ... +60 Pa
A4 -1 ... +1 mbar	L7 -100 ... +100 Pa
A5 -1.6 ... +16 mbar	R7 -160 ... +160 Pa
A6 -2.5 ... +2.5 mbar	L6 -250 ... +250 Pa
A7 -4 ... +4 mbar	R1 -400 ... +400 Pa
A8 -6 ... +6 mbar	R2 -600 ... +600 Pa
A9 -10 ... +10 mbar	L8 -1 ... +1 kPa
B1 -16 ... +16 mbar	L9 -1.6 ... +1.6 kPa
B2 -25 ... +25 mbar	M6 -2.5 ... +2.5 kPa
C5 -40 ... +40 mbar	M7 -4 ... +4 kPa
B3 -60 ... +60 mbar	M8 -6 ... +6 kPa
B4 -100 ... +100 mbar	R8 -10 ... +10 kPa
R5 -160 ... +160 mbar	R9 -16 ... +16 kPa
B6 -250 ... +250 mbar	T1 -25 ... +25 kPa

Measuring range channel 2:

[3,4]		[3,4]	
00	without	L0	-20 ... +80 Pa
		D1	0 ... 25 Pa
		D2	0 ... 40 Pa
		D3	0 ... 60 Pa
51	0 ... 1 mbar	D4	0 ... 100 Pa
97	0 ... 1.6 mbar	D5	0 ... 160 Pa
98	0 ... 2.5 mbar	D6	0 ... 250 Pa
52	0 ... 4 mbar	D7	0 ... 400 Pa
53	0 ... 6 mbar	D8	0 ... 600 Pa
54	0 ... 10 mbar	N1	0 ... 1 kPa
55	0 ... 16 mbar	N2	0 ... 1.6 kPa
56	0 ... 25 mbar	N3	0 ... 2.5 kPa
57	0 ... 40 mbar	N4	0 ... 4 kPa
58	0 ... 60 mbar	N5	0 ... 6 kPa
59	0 ... 100 mbar	E5	0 ... 10 kPa
60	0 ... 160 mbar	E6	0 ... 16 kPa
82	0 ... 250 mbar	E7	0 ... 25 kPa
		L5	-25 ... +25 Pa
		R6	-40 ... +40 Pa
		2L	-60 ... +60 Pa
A4	-1 ... +1 mbar	L7	-100 ... +100 Pa
A5	-1.6 ... +1.6 mbar	R7	-160 ... +160 Pa
A6	-2.5 ... +2.5 mbar	L6	-250 ... +250 Pa
A7	-4 ... +4 mbar	R1	-400 ... +400 Pa
A8	-6 ... +6 mbar	R2	-600 ... +600 Pa
A9	-10 ... +10 mbar	L8	-1 ... +1 kPa
B1	-16 ... +16 mbar	L9	-1.6 ... +1.6 kPa
B2	-25 ... +25 mbar	M6	-2.5 ... +2.5 kPa
C5	-40 ... +40 mbar	M7	-4 ... +4 kPa
B3	-60 ... +60 mbar	M8	-6 ... +6 kPa
B4	-100 ... +100 mbar	R8	-10 ... +10 kPa
R5	-160 ... +160 mbar	R9	-16 ... +16 kPa
B6	-250 ... +250 mbar	T1	-25 ... +25 kPa

Process connection:

[5,6]	
40	CK aluminum screw connection for 6/4 mm hose
41	CK aluminum screw connection for 8/6 mm hose
P6	Pneumatic plug connector MS nickel-plated for 6/4 mm hose
P8	Pneumatic plug connector MS nickel-plated for 8/6 mm hose
24	Cutting ring connection in stainless steel for 6 mm pipe
25	Cutting ring connection in stainless steel for 8 mm pipe

Output signal:

[7]	
0	without
<i>Preset at the factory:</i>	
C	0 ... 10 V
A	0 ... 20 mA
P	4 ... 20 mA
M	RS485 Modbus RTU

Special functions:

[8]	
0	None

Special aspects:

[9]			
0	None		
1	Sensor with increased overload and burst pressure resistance 1 bar only for the pressure ranges:		
52	0 ... 4 mbar	D7	0 ... 400 Pa
53	0 ... 6 mbar	D8	0 ... 600 Pa
54	0 ... 10 mbar	N1	0 ... 1 kPa
A6	-2.5 ... +2.5 mbar	L6	-250 ... +250 Pa
A7	-4 ... +4 mbar	R1	-400 ... +400 Pa
A8	-6 ... +6 mbar	R2	-600 ... +600 Pa
A9	-10 ... +10 mbar	L8	-1 ... +1 kPa

Approval and housing/cover colour:

[13,14]	Approval	Housing colour	Cover colour
00	None	Anthracite	Green
R1	ATEX Zone 2 and 22	Black (conductive housing)	Black

Foil keypad:

[15]	
0	FISCHER
1	Neutral

Parameterization:

[16]	Default setting ^{*)}
0	'Standard' configuration
1	'Linear characteristic curve' configuration
2	'Flow rate' configuration
3	'Table' configuration
4	'Volume flow' configuration with K-factor
5	'Equation' configuration
6	'Dynamic filter monitoring' configuration
7	'Difference' configuration
Z	'Customer-specific' configuration

) The configuration can be changed on the device at any time. The delivery condition is defined by the order code. For more information about this, please refer to the operating instructions.

3.1 Accessories

Connection cable M12

Designation	No. of Poles	length	Order no.
PUR connection cable with M12 connector	4-pin	2 m	06401993
		5 m	06401994
		7 m	06401563
		10 m	06401572
	5-pole	2 m	06401995
		5 m	06401996
		7 m	06401564
		10 m	06401573
	8-pole	2 m	09001844
		5 m	09011146
		10 m	09011016

USB interface

Designation		Order no.
Connection cable, USB-A on USB Micro-B connector	2 m	09007340
Stick USB 2.0, USB-A/Micro-B plug	16 GB	09007316

Modbus

Designation		Order no.
Terminating resistor Modbus	120 Ohm bush	06411280
	120 Ohm plug	06411279

Connection set

For connecting the differential pressure transmitter to ventilation ducts consisting of

- PVC hose
- ABS measuring socket incl. fixing screws.

Designation	Hose	Length	Order no.
Plastic connection set	2 x 6/4 mm	1 m	04005129
		2.5 m	04005148
		5 m	04005163
		10 m	04005216
	2 x 8/6 mm	1 m	04005217
		5 m	04005218

Comments:

For 2-channel devices, two connection sets may be required in some circumstances.

Complete connection set

For connecting the differential pressure transmitter to ventilation ducts consisting of

- PA hose,
- ABS measuring socket incl. fixing screws
- two M12 connectors that can be assembled
 - 1 Channel: 4pol/5pol-Socket
 - 2 Channel: 8pol/5pol-Socket

Designation	Hose	Length	Order no.	Designation
Complete connection set	1channel	4/6 mm	1 m	06411560
		6/8 mm	1 m	06411561
	2 Channel	4/6 mm	1 m	06411562
		6/8 mm	1 m	06411563

Software

The configuration software inTouch is available at fischermesstechnik.de as a download.

3.2 Information about the document

This document contains all technical data about the device. Great care was taken when compiling the texts and illustrations; Nevertheless, errors cannot be ruled out.

Subject to technical amendments.



FISCHER Mess- und Regeltechnik GmbH

Bielefelder Str. 37a
D-32107 Bad Salzuflen

Tel. +49 5222 974-0

Fax +49 5222 7170

www.fischermesstechnik.de

info@fischermesstechnik.de