

Control Motor ECM3000

The ECM3000 is a control motor designed for various industrial equipment applications.

Two models are available: 90° angular stroke motor for applications such as burner controls and 160° angular stroke motor for valve controls of hot and cold water or steam. Three kinds of control signal input types are available: relay contact, 4 to 20mA dc, and potentiometer.

Three kinds of power supply voltage types are available: 24Vac, 100Vac and 200Vac. Additionally, a power supply unit applicable to a voltage range of 85 to 264Vac is also available for the 4 to 20mA dc input type. The ECM3000 contains a standard bracket accessory for retrofitting Yamatake's older motors.

■ Features

- Robust aluminum die-cast body.
- Long life parts are used for the internal potentiometers and bearings of the motor.
- Input is selectable - 3 input types. (According to model No.) Relay contact, 4 to 20mA dc and potentiometer.
- The 90° angular stroke motor type has a pointer to indicate the position of the rotating shaft and a rotating direction label.
- Four optional auxiliary switches are available with the 90° angular stroke motor type.

■ Specifications

Model No.	Power (50/60Hz)	Input signal	Product specifications				Remarks	Auxiliary switch (option)						
			Angular stroke	Motor timing		Output torque								
				50Hz	60Hz									
ECM3000D01□0*	24Vac	Relay contact	90°	39s	33s	12.5N·m	ON/OFF operation	4 units can be built in.						
ECM3000D11□0*	100Vac	Relay contact												
ECM3000D21□0*	200Vac	Relay contact												
ECM3000E01□0*	24Vac	Potentiometer												
ECM3000F01□0*	24Vac	Relay contact												
ECM3000F11□0*	100Vac	Relay contact												
ECM3000F21□0*	200Vac	Relay contact												
ECM3000G01□0*	24Vac	4 to 20mA dc**												
ECM3000G0120	85 to 264Vac	4 to 20mA dc**							39s			Hi-speed motor type Position proportional operation	4 units can be built in.	
ECM3000G91□0*														***
ECM3000G9120						***	—							
ECM3000F03□0*	24Vac	Relay contact	20s	16s	6N·m	Hi-speed motor type Position proportional operation	4 units can be built in.							
ECM3000D0200	24Vac	Relay contact	160°	69s	58s	12.5N·m	ON/OFF operation	****						
ECM3000E0200	24Vac	Potentiometer												
ECM3000F0200	24Vac	Relay contact												
ECM3000F1200	100Vac	Relay contact												
ECM3000F2200	200Vac	Relay contact												
ECM3000G0200	24Vac	4 to 20mA dc**												
ECM3000G0220	85 to 264Vac	4 to 20mA dc**							72s			Position proportional operation	****	
ECM3000G9200														***
ECM3000G9200														***
ECM3000G9220														***
ECM3000F0400	24Vac	Relay contact	35s	29s	6N·m	Hi-speed motor type Position proportional operation	****							

Note: * An auxiliary switch (4 units) can be built into the 90° stroke motor by specifying a model No.

Code for □ in model No. 0: Auxiliary switch is not built in
1: Type with 4 auxiliary switches built in

** User can switch direct/reverse control action and adjust zero/span and dead band.

*** Position proportional operation + 2 auxiliary switches + open/close override function

**** Extension unit applicable later

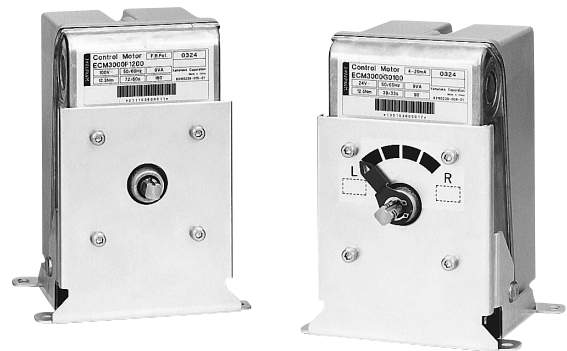

- For both 90° and 160° angular stroke motors, models with two auxiliary switches and open/close override function are also available.
- Splash-proof structure IP54 or equivalent, superior to environment resistance.
- Motor mounting bracket (standard accessory part) is compatible to replacing from Yamatake's older motor being used at present.
- Two angular strokes available for several applications. 90° type and 160° type
- Output torque is 12.5N·m.
- A CE-marked and cUL-certified product (24Vac model only).

⚠ Handling Precautions

- The high-speed motor type must be used within a duty ratio (operation ratio) of 40%.
- Do not connect the ECM3000F model to a mechanical balancing relay (R9107A, R927C, etc.). Doing so might damage the control motor by applying excessive voltage to its potentiometer.

! Handling Precautions

- If an ECM3000F model controls the actuator on the basis of the resistance between T and G or between T and Y of the feedback potentiometer, it might not function normally, depending on the connected controller. For details, contact a Yamatake Corporation sales representative.
- Be sure to apply non-voltage wiring to terminals S, CONT, CW, and CCW of ECM3000 models with an open/close override function. In some cases M744 and M7284 control motors take 24Vac to terminals S, CONT, CW, and CCW. If one of these models is replaced with an ECM3000 with open/close override function, be sure not to apply 24Vac to these terminals, or else the circuits may burn out.
- With ECM3000F and ECM3000D models, be sure that the leak current from the snubber circuit used to protect the motor-driving element (relay, SSR) does not exceed the following (listed by power supply voltage):
 1. 100V: 0.8mA (RMS) max.
 2. 200V: 0.4mA (RMS) max.

■ Specifications

Item	Description		
Basic specifications	Operation mode (fixed according to model No.)	ON-OFF, position proportioning, or open/close override	
	Input signal (fixed according to model No.)	Relay contact, 4 to 20mA _{dc} , potentiometer (nominal 135Ω)	
	Feedback potentiometer Nominal value	135Ω, 0.5W	
	Potentiometer Max. applied voltage	5V _{dc}	
	Input impedance (for 4 to 20mA _{dc} input signal)	45Ω ± 5%	
	Angular stroke (selectable by model No.)	90° or 160°	
	Motor timing	90° models: 39/33s ± 5s (relay contact, no load, 50/60Hz) 39s ± 5s (85–64Vac 50/60Hz power, no load) 20/16s ± 3s (relay contact, no load, 50/60Hz, high-speed motor)	
		160° models: 69/58s ± 5s (relay contact, no load, 50/60Hz) 72s ± 10s (85–264Vac 50/60Hz power, no load) 35/29s ± 3s (relay contact, no load, 50/60Hz, high-speed motor)	
	Output torque	12.5N·m (high-speed motor type 6N·m)	
	Power supply voltage (fixed according to model No.)	24Vac ± 15% / 100Vac ± 10% / 200Vac ± 10% / 85 to 264Vac. Frequency: 50/60Hz	
	Power consumption (during operation)	9VA (relay contact, potentiometer, 4 to 20mA type) 11VA (open/close override function, 4 to 20mA, 24Vac type) 14W (4 to 20mA, 85 to 264Vac type) 15W (open/close override function, 4 to 20mA, 85 to 264Vac type) 14VA (high-speed motor type)	
	Protection	Splash-proof structure IP54 or equivalent when water-proof cable gland is used.	
	Material	Case: Die-cast aluminum Cover: Polycarbonate resin with GF Bracket: Steel	
Mass (weight)	Approx. 3kg		
Reference operating conditions	Temperature	23 ± 2°C	
	Humidity	50 ± 10%RH	
Rated operating conditions	Ambient temperature	-20 to +60°C	
	Ambient humidity	5 to 95%RH (no condensation allowed)	
	Vibration resistance	4.9m/s ²	
Operation limits	Ambient temperature	-20 to +60°C	
	Ambient humidity	5 to 95%RH (no condensation allowed)	
	Vibration resistance	9.8m/s ²	
Transportation/storage conditions (packaged condition)	Temperature	-20 to +70°C	
	Humidity	5 to 95%RH (no condensation allowed)	
	Vibration resistance	19.6m/s ²	
Insulation resistance	Between power supply terminals and casing, and between input terminals and casing	5MΩ or more by 500V _{dc} megger	
	Between auxiliary switch terminals and casing	20MΩ or more by 500V _{dc} megger	
Dielectric strength	Between power supply terminals and casing, and between input terminals and casing	24Vac type	500Vac, 60s
		100Vac type	1200Vac, 60s
		200Vac type	1500Vac, 60s
		85 to 264Vac type	1500Vac, 60s
	Between auxiliary switch terminals and casing	1500Vac, 60s	
Auxiliary switch/open/close override input (option)	Number of inputs	4 (2) Note: 2 inputs for models with open/close override	
	Contact rating	250Vac, 5A (resistive load)	
	Position at factory setting	For 90° angular stroke motors with built-in auxiliary switch, at factory settings: Close → Open (A, C): 9° ± 5° Open → Close (B, D): 81° ± 5°	
	Settable range	Output opening range of 5 to 95%. However, it must be the internal area of end switches.	
	Repeatability	±3%	
	Operation type	1 – 2 terminals: NO, 1 – 3 terminals: NC	
Safety certification (24Vac model only)	CE marking	EN55011, EN61000	
	cUL certification	cUL standard	

Optional parts

Name		Part No.
Crank arm		N-3128
Damper arm		J-26026G-ARM
Valve linkage		Q455C, D
Damper linkage		Q605A, D, E
Base kit for V51E		83165292-001
Waterproof connector		83104346-003
24Vac power supply transformer		AT72-J1
Extension unit*	Auxiliary switches (4 units built-in)	83165271-004
	Auxiliary potentiometer for 90° type**	83165272-001
	Auxiliary potentiometer for 160° type**	83165272-002

* Only one type of extension unit can be mounted on the model without internal auxiliary switch.

** The total resistance of the auxiliary potentiometer is $1k\Omega \pm 10\%$.
The output of the auxiliary potentiometer cannot be connected to an M904E Modutrol motor and to an ECM3000E control motor. Use the potentiometer for output to an external degree of opening indicator or the like.

Using a butterfly valve (V51E)

If the ECM3000 is used with the V51E, mount the base kit (83165292-001, sold separately) between the V51E and the ECM3000.

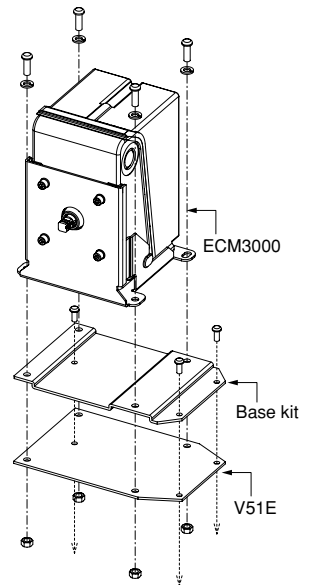

Dimensions

Angular stroke	A dimension	B dimension	C dimension
90° type	32.5	161.6	22
160° type	20.5	149.6	12

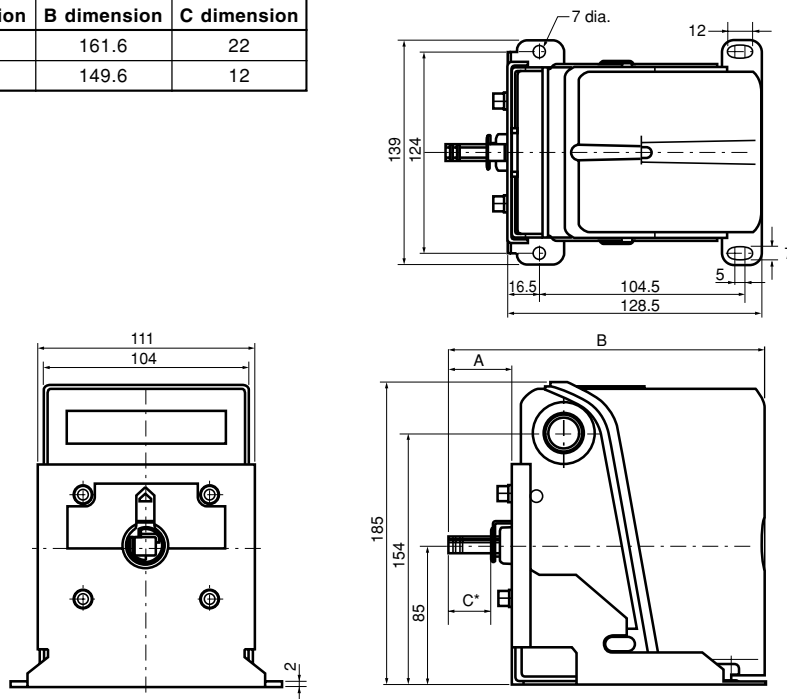

(Unit: mm)

* Size C shows the length of the output shaft (9.5 square).

● 0° position of the output shaft (view from the output shaft)

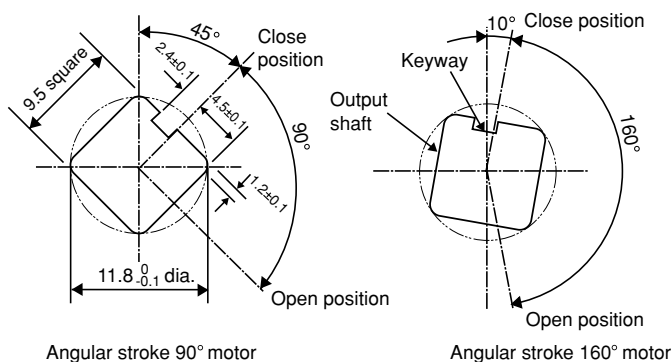

Handling Precautions

- The length of the output shaft differs depending on the model number.
- On 90° models the pointer is attached.

■ Mounting precautions

● Mounting locations

Do not install the ECM3000 at locations shown below.

- Locations where hazardous chemicals, corrosive gas or briny/salty air exists.
- Locations where the ECM3000 is exposed to high temperatures.
- Locations where moisture or droplets exist.
- Locations where the ECM3000 is exposed to vibrations for a long period.
- Locations where the ECM3000 is exposed to direct sunlight.

Additionally, when installing the ECM3000 outdoors, an appropriate protective device such as protective cover must be installed.

! Handling Precautions

Pay special attention so that any foreign matter or moisture content does not enter from the output shaft. In an application that the ECM3000 is combined with a control valve, such as fluid control, condensed moisture content is transferred from the valve and might enter the internals of the motor.

● Mounting direction

• Angular stroke 90° motor

This type can be mounted in a desired direction with its motor output shaft pointing horizontally or vertically upward.

• Angular stroke 160° motor

This type can be mounted in the desired direction with the motor output shaft placed horizontally or vertically downward.

To prevent condensate water from entering the ECM3000, do not mount with the output shaft pointing upward.

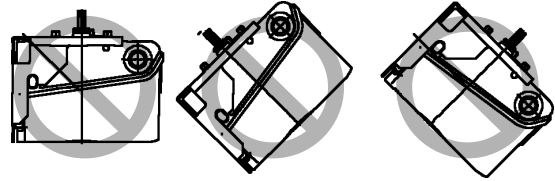

■ Wiring

L : counterclockwise (CCW) rotation
R : clockwise (CW) rotation

● Relay contact input (24Vac power supply)

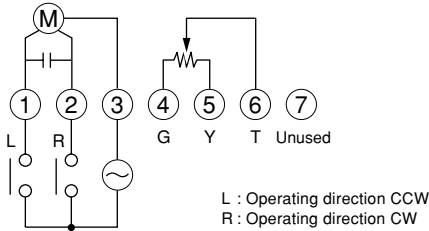

! Handling Precautions

In using ON-OFF control action, terminal No. 4, 5 and 6 are not connected.

● Potentiometer (135Ω) input (24Vac power supply)

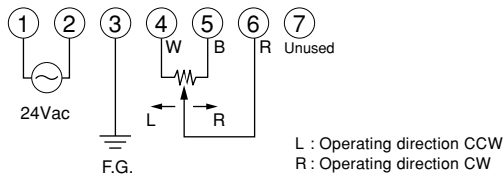

● 4 to 20mA input (24Vac power supply)

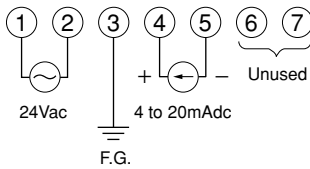

! Handling Precautions

Terminals 2 and 5 are isolated from each other inside the motor.

● 4 to 20mA input (85 to 264Vac power supply)

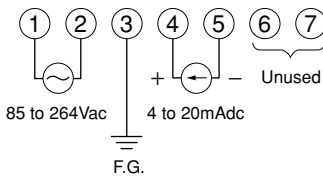

! Handling Precautions

Terminals 2 and 5 are isolated from each other inside the motor.

● Relay contact input (100Vac/200Vac power supply)

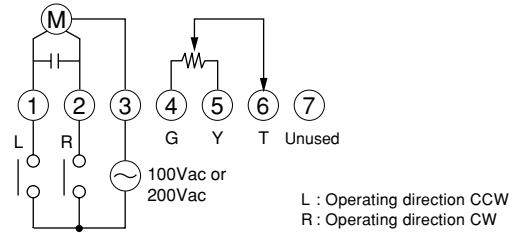

! Handling Precautions

- Set the parameters of the controller, (for example derivative time (D) is set to 0 second or dead band is widened), so that the internal relay of the controller does not repeat ON and OFF excessively due to hunting during motor operation. If the internal relay operates excessively, the life of the motor or the relay of the controller on the host side might be shortened. If frequent operation cannot be avoided, an auxiliary relay must be installed between the motor and the controller.
- The maximum allowable voltage to the feedback potentiometer is 5Vdc. Mechanical balancing relays (e.g., Yamatake models R9107A, R927C, etc.) cannot be used.

● Auxiliary switch (4 units)

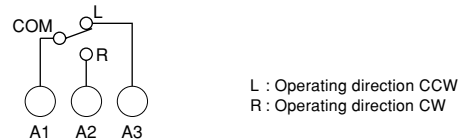

Note: The connection of internal switches from B to D is same as the connection of A. Models with open/close override function have only A and B switches.

● Open/close override input

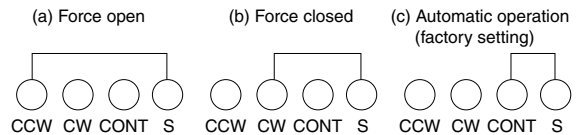

Notes: • At any one time, terminal S may be connected to only one of CCW, CW and CONT.

- Be sure to apply non-voltage wiring to terminals S, CONT, CW, and CCW of ECM3000 models with an open/close override function. In some cases M744 and M7284 control motors take 24Vac to terminals S, CONT, CW, and CCW. If one of these models is replaced with an ECM3000 with open/close override function, be sure not to apply 24Vac to these terminals, or else the circuits may burn out.

● Full open/full close operation for ECM3000E

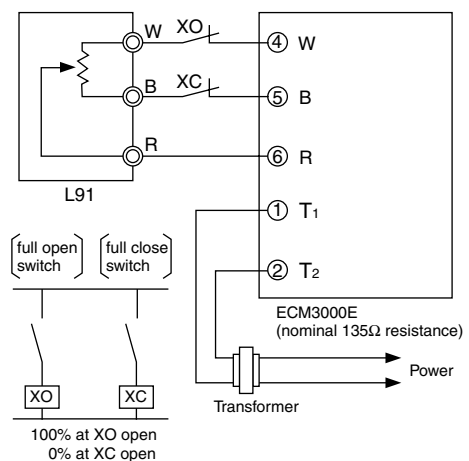



RESTRICTIONS ON USE

This product has been designed, developed and manufactured for general-purpose application in machinery and equipment. Accordingly, when used in the applications outlined below, special care should be taken to implement a fail-safe and/or redundant design concept as well as a periodic maintenance program.

- **Safety devices for plant worker protection**
- **Start/stop control devices for transportation and material handling machines**
- **Aeronautical/aerospace machines**
- **Control devices for nuclear reactors**

Never use this product in applications where human safety may be put at risk.

Specifications are subject to change without notice.

azbil

Yamatake Corporation Advanced Automation Company

1-12-2 Kawana, Fujisawa
Kanagawa 251-8522 Japan
URL: <http://www.azbil.com>

Printed in Japan. (H)
1st Edition: Issued in July, 2004
2nd Edition: Issued in Nov., 2007

No part of this publication may be reproduced or duplicated without the prior written permission of Yamatake Corporation.

Printed on recycled paper.

(07)